



UTAH
LABOR COMMISSION
Boiler, Elevator and Coal Mine Safety Division

**Test Preparation Study Guide
for
Coal Miner Certification**

UNDERGROUND FIRE BOSS

**Test Preparation Study Guide
For
Underground Fire Boss Certification**

FIRE BOSS



*This guide was developed by the Utah Labor Commission.
The CFR references throughout this guide are current as of 2014.*

Tables of Contents

CHAPTER 1

Mine Gases	Page
Methane	6
Carbon Monoxide	7
Carbon Dioxide	9
Hydrogen Sulfide	10
Hydrogen	12
Sulfur Dioxide	13
Nitrogen Dioxide	14
Nitrogen	15
Oxygen	16
Acetylene	17
Properties of Air	20
Types of Coal	21
Properties of Mine Gases	22
Code of Federal Regulations Part 75	23
Questions and Review	26

CHAPTER 2

Fires and Explosions	Page
Historical Mine Disasters	30
Fire Classification	31
Mining Terms for Explosive Mixtures	34
Code of Federal Regulations Part 75	36
Questions and Review	48

CHAPTER 3

Ventilation	Page
Purpose and challenges of mine ventilation	52
Code of Federal Regulations - Main Mine Fans	54
Winter Alert Program	61
Math Formulas	63
Mine Map Symbols	64
Ventilating Mine Maps	68
Basic Mine Ventilation - MSHA's Illustration	76
Code of Federal Regulations Part 75– Subpart D	105
Questions and Review	134

CHAPTER 4

Electricity	Page
Electrical Accidents	138
High and Low Voltages	139
Electrical Symbols	140
Federal Mine Safety & Health Act of 1977	142
Code of Federal Regulations Part 75	151
Questions and Review	161

CHAPTER 5

Mine Law	Page
Federal Mine Safety & Health Act of 1977	164
Code of Federal Regulations Part 50	200
Code of Federal Regulations Part 75	205
Utah State Code	241
Questions and Review	252

CHAPTER 6

Instruments and Definitions	Page
Instruments	256
Definition of Coal Mining Terms	266
Questions and Review	294

CHAPTER 7

Blasting and Explosives	Page
Coal Blasting	297
Definitions of Blasting Terms	299
Code of Federal Regulations Part 75 – Subpart N	301
Questions and Review	314

CHAPTER ONE

MINE GASSES

1. Methane
2. Carbon Monoxide
3. Carbon Dioxide
4. Hydrogen Sulphide
5. Hydrogen
6. Sulfur Dioxide
7. Nitrogen Dioxide
8. Nitrogen
9. Oxygen
10. Acetylene
11. Properties of Air
12. Types of Coal
13. Properties of Mine Gases
14. Code of Federal Regulations Part 75
15. Questions and Review

Methane



Methane is a colorless, odorless, flammable gas. It is lighter than air, having a specific gravity of 0.554 and is often found near the mine roof (ceiling of the mine opening). It is only slightly soluble in water. It burns readily in air, forming carbon dioxide and water vapour; the flame is pale, slightly luminous, and very hot. The boiling point of methane is -162.0° C (-259.6° F) and the melting point is -182.5° C (-296.5° F). Methane in general is very stable, but mixtures of methane and air are explosive. Explosions of such mixtures have been frequent in coal mines and collieries and have been the cause of many mine disasters. The most volatile explosion of methane and air mixture occurs when methane content is at 10 percent.

When mixed with air, methane is explosive in concentrations between approximately 5% and 15%. Liquid methane does not burn unless subjected to high pressure.

Potential health effects

Methane is not toxic; however, it is highly flammable and may form explosive mixtures with air. High concentrations of the gas in closed spaces, may reduce the oxygen percentage in air and cause suffocation. Asphyxia may result if the oxygen concentration is reduced to below 19.5% by displacement.

Facts About Methane

- Methane gas occurs naturally in all coal mines, trapped in pores within the coal bed. It is released as the coal is broken up during the mining process. The amount of methane liberated by the coal depends on the geologic age and type of coal and the depth of the coal deposit. Natural gas used in household furnaces is composed mostly of methane.
- Methane can be detected with hand-held or stationary instruments. Checks for methane are made by certified persons at regular intervals before and during the time while people are working underground.
- Federal safety standards mandate that, “when 1.0 percent or more methane is present in a working place or an intake air course, electrically powered equipment in the affected area shall be de-energized, and other mechanized equipment shall be shut off.”
- A flammable mixture of methane and air can be ignited by electric arcs and sparks, open flames or by the heat of friction between the cutting bits of mining equipment and the mine rock immediately above or below the coal.

Coal Mines and Methane

Methane emissions in working mines arise at two key stages:

(1) Methane is released as a direct result of the physical process of coal extraction. In many modern underground mines, the coal is extracted through longwall mining. Longwall mining, as with other sub-surface techniques, releases methane previously trapped within the coal seam into the air supply of the mine as layers of the coal face are removed, thus creating a potential safety hazard.

(2) Methane emissions arise from the collapse of the surrounding rock strata after a section of the coal seam has been mined and the artificial roof and wall supports are removed as mining progresses to another section. The debris resulting from the collapse is known as gob and also releases methane or 'gob gas' into the mine.

Carbon monoxide

CO

Carbon Monoxide is a colorless, odorless and tasteless gas, which is highly toxic to humans and animals. It is produced from the incomplete combustion or explosion of substances containing carbon such as coal, natural gas or gasoline. Large quantities of CO are generated during mine fires or explosions.

Carbon monoxide is slightly lighter than air. It is flammable and explosive in mixtures with air in concentrations between 12.5 and 74%. It is toxic because it blocks the ability of the hemoglobin in the blood to carry oxygen from the lungs to the muscles and other tissue in the human body.

Coal Mines and Carbon Monoxide

Carbon monoxide may be present in the afterdamp of a gas- or coal-dust explosion, or in the gases given off by a mine fire; also one of the gases produced by blasting. It is an important constituent of illuminating gas, supports combustion, and is very poisonous.

Carbon monoxide (sometimes referred to as "white damp") is the most dangerous gas to be dealt with in a mine. Unlike carbon dioxide, which as the levels increase the density makes it sink, carbon monoxide is lighter than air and subsequently more deadly because of it. It can be caused by explosions either from fire damp or coal dust (thus being an integral part of after damp). In addition to being toxic, it is also very flammable.

The NIOSH recommended exposure limit (REL) for CO is 35 ppm, measured as a time-weighted average (TWA) for up to a 10-hour workday during a 40-hour work week. The ceiling concentration (not to be exceeded during any part of the workday) is 200 ppm. CO in concentrations of 500 ppm or 0.05% can be fatal in 3 hours. Higher concentrations can lead to coma and death in minutes. Carbon monoxide is known as a “silent killer”.

Carbon monoxide can be detected by hand-held sensors. Stationary sensors may also be installed at strategic points in mine airways.

Effects on Life

Carbon monoxide is so dangerous to humans because it is so readily absorbed by the blood—even more than just oxygen. Making it worse, the body is slow to "give it up," making treatment that much more difficult. Also, because the body continues to absorb the gas (death comes at 80% saturation), even low levels can build up in the body causing death. It is at about 0.02% that one begins feeling the effects—in this case, "slight giddiness, headache and breathlessness" If the level gets as high as 0.2%, death will take place in one to two hours. The amount of time before a fatality (from there on up), is dependent not only on the percentage of carbon monoxide, but the amount of exertion by the person.

Because, unlike carbon dioxide, flames won't extinguish or die down in the presence of carbon monoxide, one of the chief tests was done by bringing small animals, usually birds (the proverbial "canary in a coal mine") and mice. They would succumb much sooner than a full grown man or even a boy.

Symptoms Associated With a Given Concentration of CO Over Time

PPM CO	Time	Symptoms
35	8 hours	Maximum exposure allowed by OSHA in the workplace over an eight hour period.
200	2-3 hours	Mild headache, fatigue, nausea and dizziness.
400	1-2 hours	Serious headache-other symptoms intensify. Life threatening after 3 hours.
800	45 min	Dizziness, nausea and convulsions. Unconscious within 2 hours. Death within 2-3 hours.
1600	20 min	Headache, dizziness and nausea. Death within 1 hour.
3200	5-10 min	Headache, dizziness and nausea. Death within 1 hour.
6400	1-2 min	Headache, dizziness and nausea. Death within 25-30 minutes.
12,800	1-3 min	Death

Carbon Dioxide

CO₂

At room temperature, **carbon dioxide** takes the form of an odorless, colorless gas which is incombustible in normal conditions. Carbon dioxide can be forced into a solid form, in which case it is known as dry ice, and the gas is toxic to animals in high concentrations. People who inhale too much carbon dioxide essentially suffocate, ultimately falling into unconsciousness as their oxygen saturation level drops.

Carbon dioxide is a trace gas being only 0.038% of the atmosphere. It is produced through decomposition of organic materials as well as through respiration and combustion. It is also generated as a by-product of the combustion of fossil fuels or the burning of vegetable matter, among other chemical processes.

Coal Mines and Carbon Dioxide

Besides being a part of both after damp and black damp, as noted above, carbon dioxide levels increase due to human and (in some cases, particularly in the past) animal respiration. Other sources include burning of candles or torches (less common since electricity came to mining), explosions, chemical reactions with certain rocks/minerals, even the decay of timber. One of the key tasks of a mine ventilation system is to get rid of carbon dioxide (hardly the most deadly, but the one most apt to build up in the day to day operation of a mine).

While not combustible or poisonous, by itself, levels of 18% can kill, 25% quickly. If it is combined with a corresponding drop in the percentage of oxygen, those numbers can drop to 9% and 10%, respectively. Levels as low as 3% can make breathing more difficult, symptoms worsening as the percentage rises.

Effects on Life

While carbon dioxide does contribute to maintaining human health by maintaining the pH balance of blood, it can lead to suffocation when the concentration is too high.

CO₂ is toxic in higher concentrations: 1% (10,000 ppm) will make some people feel drowsy. When inhaled at concentrations much higher than usual atmospheric levels, it can produce a sour taste in the mouth and a stinging sensation in the nose and throat. Concentrations of 7% to 10% cause dizziness, headache, visual and hearing dysfunction, and unconsciousness within a few minutes to an hour.

Hydrogen Sulfide

H₂S

Hydrogen sulfide is a colorless, highly toxic and flammable gas. Being heavier than air, it tends to accumulate at the bottom of poorly ventilated spaces. It smells like rotten eggs and is sometimes called hydrosulfuric acid, stink gas or sewer gas. Although very pungent at first, it quickly deadens the sense of smell, so potential victims may be unaware of its presence until it is too late.

- 0.0047 ppm is the recognition threshold, the concentration at which 50% of humans can detect the characteristic odor of hydrogen sulfide
- Less than 10 ppm has an exposure limit of 8 hours per day.
- 10–20 ppm is the borderline concentration for eye irritation.
- 50–100 ppm leads to eye damage.
- At 150–250 ppm the olfactory nerve is paralyzed after a few inhalations, and the sense of smell disappears, often together with awareness of danger,
- 320–530 ppm leads to pulmonary edema with the possibility of death.
- 530–1000 ppm causes strong stimulation of the central nervous system and rapid breathing, leading to loss of breathing;
 - 800 ppm is the lethal concentration for 50% of humans for 5 minutes exposure(LC50).
- Concentrations over 1000 ppm cause immediate collapse with loss of breathing, even after inhalation of a single breath.

Health Effects of Hydrogen Sulfide

H₂S is classed as a **chemical asphyxiant**, similar to carbon monoxide and cyanide gases. It inhibits cellular respiration and uptake of oxygen, causing biochemical suffocation. Typical exposure symptoms include:

L O W	0 - 10 ppm	Irritation of the eyes, nose and throat
M E D	10 - 50 ppm	Headache Dizziness Nausea and vomiting Coughing and breathing difficulty
H I G H	50 - 200 ppm	Severe respiratory tract irritation Eye irritation / acute conjunctivitis Shock Convulsions Coma Death in severe cases

Prolonged exposures at lower levels can lead to bronchitis, pneumonia, migraine headaches, pulmonary edema, and loss of motor coordination.

Should a co-worker ever be overcome by H₂S gas, do not attempt a rescue until you are properly protected yourself. The rescuer can very easily get caught out by venturing into a confined space without adequate protection. Remember that at levels above 200 ppm, collapse, coma and death due to respiratory failure can occur within seconds after only a few inhalations so you can be overcome yourself very quickly. Such incidents are sadly all too common and only serve to make the rescue effort twice as difficult.

Coal Mines and Hydrogen Sulfide

Hydrogen Sulfide, also known as "stink damp," the gas is caused by the decomposition of iron pyrites in a mine due to the dampness or presence of water. While considerably more deadly than carbon monoxide (and inflammable), amounts of this gas are usually only trace. Another thing in favor of the miners is that the gas has a foul, disagreeable odor (like rotten eggs) which serves as a usually adequate warning.

Like carbon dioxide, it is heavier than air and sinks. Animals could also be used to test for it by placing them near the floor of the mine (1% could cause death rather quickly and as little as 0.07%, over time, could also kill) but the smell and relative nonabundance of the gas make it less of a concern than the others.

While proper ventilation and methods to test for gases have come a long way since they actually used animals to test, the danger of gas buildup in a coal mine is a constant and important concern. Awareness of the potential problem and knowledge of the safety procedures are an important part of keeping men alive who spend so much of their lives digging underground for coal.

Hydrogen

H₂

Hydrogen is the lightest element. It is by far the most abundant element in the universe and makes up about about 90% of the universe by weight. Hydrogen as water (H₂O) is absolutely essential to life and it is present in all organic compounds. Hydrogen is the lightest gas. Hydrogen gas was used in lighter-than-air balloons for transport but is far too dangerous because of the fire risk. It burns in air to form only water as waste product and if hydrogen could be made on sufficient scale from other than fossil fuels then there might be a possibility of a hydrogen economy.

Table: basic information about and classifications of hydrogen.

Name : Hydrogen	Group in periodic table : 1
Symbol : H	Group name : (none)
Atomic number : 1	Period in periodic table : 1
Atomic weight : 1.00794 (7)	Block in periodic table : s-block
Standard state : gas at 298 K	Color : colorless
CAS Registry ID : 1333-74-0	Classification : Non-metallic

Properties/Combustion

Hydrogen gas is highly flammable and will burn in air at a very wide range of concentrations between 4% and 75% by volume. The enthalpy of combustion for hydrogen is -286 kJ/mol:
 $2 \text{H}_2(\text{g}) + \text{O}_2(\text{g}) \rightarrow 2 \text{H}_2\text{O}(\text{l}) + 572 \text{ kJ (286 kJ/mol)}$

Hydrogen gas forms explosive mixtures with air in the concentration range 4-74% (volume per cent of hydrogen in air) and with chlorine in the range 5-95%. The mixtures spontaneously detonate by spark, heat or sunlight. The hydrogen autoignition temperature, the temperature of spontaneous ignition in air, is 500 °C (932 °F). Pure hydrogen-oxygen flames emit ultraviolet light and are nearly invisible to the naked eye. The detection of a burning hydrogen leak may require a flame detector; such leaks can be very dangerous. The destruction of the Hindenburg airship was an infamous example of hydrogen combustion; the cause is debated, but the visible flames were the result of combustible materials in the ship's skin. Because hydrogen is buoyant in air, hydrogen flames tend to ascend rapidly and cause less damage than hydrocarbon fires.

H₂ reacts with every oxidizing element. Hydrogen can react spontaneously and violently at room temperature with chlorine and fluorine to form the corresponding hydrogen halides, hydrogen chloride and hydrogen fluoride, which are also potentially dangerous acids.

Safety and precautions

Hydrogen poses a number of hazards to human safety, from potential detonations and fires when mixed with air to being an asphyxiant in its pure, oxygen-free form. In addition, liquid hydrogen is a cryogen and presents dangers (such as frostbite) associated with very cold liquids. Hydrogen dissolves in many metals, and, in addition to leaking out, may have adverse effects on them, such as hydrogen embrittlement, leading to cracks and explosions. Hydrogen gas leaking into external air may spontaneously ignite. Moreover, hydrogen fire, while being extremely hot, is almost invisible, and thus can lead to accidental burns.

Even interpreting the hydrogen data (including safety data) is confounded by a number of phenomena. Many physical and chemical properties of hydrogen depend on the parahydrogen/orthohydrogen ratio (it often takes days or weeks at a given temperature to reach the equilibrium ratio, for which the data is usually given). Hydrogen detonation parameters, such as critical detonation pressure and temperature, strongly depend on the container geometry.

Sulfur Dioxide

SO₂

Sulfur dioxide (also **sulphur dioxide**) is a heavy, colorless, poisonous gas with a pungent odor, familiar as the smell of a just-struck match. It is a liquid when under pressure, and it dissolves in water very easily. Since coal and petroleum often contain sulfur compounds, their combustion generates sulfur dioxide. Further oxidation of SO₂, usually in the presence of a catalyst such as NO₂, forms H₂SO₄, and thus acid rain. Large quantities of sulfur dioxide are formed in the combustion of sulfur-containing fuels.

Effects on Life

Sulfur dioxide is toxic in large amounts and can be life threatening. Exposure to 100 ppm is considered immediately dangerous to human life and health. Burning of the nose and throat, breathing difficulties, and severe airway obstructions occurred in miners who breathed Sulfur Dioxide released as a result of exposure. Sulfur dioxide blocks nerve signals from the pulmonary stretch receptors (PSR's). Inhaling sulfur dioxide has been associated with increased respiratory symptoms and disease and premature death.

Sources: Combustion of fuel containing sulfur -- mostly coal and oil. Also produced during metal smelting and other industrial processes.

Nitrogen Dioxide

NO₂

Nitrogen Dioxide is a reddish-orange brown, gas with a characteristic sharp, biting odor and it is toxic. It is produced when fossil fuels (like gasoline or diesel) are burned. It dissolves in water with reaction to give a mixture of nitric acid and nitrous acid.

Exposure to Nitrogen dioxide

People are exposed to NO₂ by breathing in the gas from the air. The levels of NO₂ are usually higher outdoors than indoors. The operation of gas or diesel engines in enclosed areas can result in a build up of dangerous levels of NO₂ in the air.

When energy sources burn fuel incompletely, there is the risk of NO₂ being produced. Gases produced by electric arc welding may also contain dangerous levels of nitrogen dioxide. Traces of NO₂ can be found in tobacco smoke.

Effect on Life

Nitrogen dioxide is toxic by inhalation, but this could be avoided as the material is acrid and easily detected by our sense of smell.

Low concentrations (4 ppm) will anesthetize the nose, thus creating a potential for overexposure. Breathing low levels of nitrogen dioxide can cause a slight cough, mild fatigue, and nausea. Eye, nose, and throat irritation are also common symptoms.

High concentrations of NO₂ can cause severe coughing, choking, headache, nausea, abdominal pain, and shortness of breath. If the exposure is severe, symptoms may continue after the exposure has ended, causing difficulty breathing for weeks.

Long-term exposure to NO₂ at concentrations above 40– 100 µg/m³ causes adverse health effects.

Nitrogen dioxide is a pulmonary irritant affecting primarily the upper respiratory system. Individuals with asthma, respiratory disorders and lung diseases are more sensitive to the effects of NO₂. Healthy individuals exposed to concentrations of NO₂ from 0.7 to 5.0 ppm for 10-15 minutes have developed abnormalities in pulmonary airway resistance. At higher concentrations it can irritate the lungs, cause bronchitis and pneumonia and lower resistance to respiratory infections.

Health problems caused by nitrogen dioxide can either be acute, which occur immediately or within a few days of exposure, or they can be chronic, which are long-term health effects that might not show up for many years

Nitrogen

N₂

Nitrogen makes up the major portion of the earth's atmosphere, accounting for 78.08% of the air by volume. Nitrogen gas is a colorless, odorless, tasteless, nontoxic and almost totally inert gas. It is nonflammable and it will not support combustion. Nitrogen gas is slightly lighter than air and slightly soluble in water.

Nitrogen condenses at its boiling point, -195.8°C (-320.4°F), turning into a colorless liquid that is lighter than water. It will freeze at -210°C ; (-346°F .)

Uses of Nitrogen

It is commonly thought of and used as an inert gas; but it is not truly inert. It forms nitric oxide and nitrogen dioxide with oxygen, ammonia with hydrogen, and nitrogen sulfide with sulfur. It is used to shield potentially reactive materials from contact with oxygen

Liquid nitrogen is valued for coldness as well as inertness. When liquid nitrogen is vaporized and warmed to ambient temperature, it absorbs a large quantity of heat. The inert properties of nitrogen make it a good blanketing gas in many applications. Nitrogen blanketing is used to protect flammable or explosive solids and liquids from contact with air. When working with liquid nitrogen, proper ventilation is very important.

Nitrogen is principally shipped and used in either gaseous or liquid form. When appropriately insulated from ambient heat, liquid nitrogen can be stored and transported, for example in vacuum flasks. Depending on the size and design, the holding time of vacuum flasks ranges from a few hours to a few weeks.

Effect on Life

When inhaled at high partial pressures nitrogen begins to act as an anesthetic agent. It can cause nitrogen narcosis, a temporary semi-anesthetized state of mental impairment similar to that caused by nitrous oxide.

Direct skin contact with liquid nitrogen will eventually cause severe frostbite. This may happen almost instantly on contact, depending on the form of liquid nitrogen.

As liquid nitrogen evaporates it will reduce the oxygen concentration in the air and might act as an asphyxiant, especially in confined spaces. Nitrogen may produce asphyxia without any sensation or prior warning.

Vessels containing liquid nitrogen can condense oxygen from air. The liquid in such a vessel becomes increasingly enriched in oxygen as the nitrogen evaporates, and can cause violent oxidation of organic material.

Oxygen

O₂

Oxygen is a colorless odorless tasteless gas. Atmospheric oxygen is of vital importance for all aerobic organisms. It is used in high-temperature flames and in breathing apparatus. Oxygen occurs in the free state as a gas, and makes up approximately 21% of the air we breathe.

Properties

- A colorless gas, without smell or taste,
- Is slightly heavier than air,
- Is sparingly soluble in water,
- Is difficult to liquefy, boiling point -183 °C, and the liquid is pale blue in color and is appreciably magnetic. At still lower temperatures, light-blue solid oxygen is obtained, which has a melting point of -218.4 °C

Uses

Oxygen is essential for life and it takes part in processes of combustion, its biological functions in respiration make it important.

Oxygen is sparingly soluble in water, but the small quantity of dissolved oxygen in is essential to the life of fish.

Oxygen gas is used with hydrogen or coal gas in blowpipes and with acetylene in the oxy-acetylene torch for welding and cutting metals.

Liquid oxygen mixed with powdered charcoal has been used as an explosive.

Combustion and other hazards

Highly concentrated sources of oxygen promote rapid combustion. Fire and explosion hazards exist when concentrated oxidants and fuels are brought into close proximity; however, an ignition event, such as heat or a spark, is needed to trigger combustion.

Concentrated O₂ will allow combustion to proceed rapidly and energetically. Steel pipes and storage vessels used to store and transmit both gaseous and liquid oxygen will act as a fuel; and therefore the design and manufacture of O₂ systems requires special training to ensure that ignition sources are minimized.

Liquid oxygen spills, if allowed to soak into organic matter, such as wood, petrochemicals, and asphalt can cause these materials to detonate unpredictably on subsequent mechanical impact. As with other cryogenic liquids, on contact with the human body it can cause burns to the skin and the eyes.

Acetylene

C₂H₂

Acetylene Gas also called *ethyne*. – is a hydrocarbon consisting of two carbon atoms and two hydrogen atoms. It is a colorless, highly flammable, explosive gas with a garlic-like odor.

Acetylene has the highest flame temperature of any common hydrocarbon because of its triple-bond structure H-C≡C-H. Combustion with oxygen achieves a flame temperature of 5580° F (3087° C), releasing 1470 BTUs per cubic foot. Its high flame temperature allows it to be used in a variety of metal working applications like cutting, welding, brazing, and soldering.

Safety and handling

When acetylene is liquefied, compressed, heated, or mixed with air, it becomes highly explosive. As a result special precautions are required during its production and handling.

Acetylene is not especially toxic but when generated from calcium carbide it can contain toxic impurities such as traces of phosphine and arsine. It is also highly flammable (hence its use in welding). Its singular hazard is associated with its intrinsic instability; samples of concentrated or pure acetylene will explosively decompose. Acetylene can explode with extreme violence if the pressure of the gas exceeds about 200 kPa (29 psi) as a gas or when in liquid or solid form.

It is therefore shipped and stored dissolved in acetone or dimethylformamide (DMF), contained in a metal cylinder with a porous filling, which renders it safe to transport and use, given proper handling.

MSHA – Safety Hazard Information Special Hazards of Acetylene

Acetylene is the most common gas used for fueling cutting torches in both general industry and the mining industry. When mixed with pure oxygen in a cutting torch assembly, an acetylene flame can theoretically reach over 5700°F. Users of this type of equipment are generally familiar with the fire hazards associated hot flames and the production of hot slag. However, many users may not be aware of the unique characteristics of acetylene itself that create special hazards compared to other fuel gases.

Chemical Composition: An acetylene molecule is composed of two carbon atoms and two hydrogen atoms. The two carbon atoms are held together by what is known as a triple carbon bond. This bond is useful in that it stores substantial energy that can be released as heat during combustion. However, the triple carbon bond is unstable, making acetylene gas very sensitive to conditions such as excess pressure, excess temperature, static electricity, or mechanical shock.

Storage: Because of acetylene's unstable nature, it must be stored under special conditions. This is accomplished by dissolving the acetylene in liquid acetone. The liquid acetone is then stored in the acetylene cylinder, which in turn, is filled with a porous (sponge-like) cementitious material.

- NEVER ATTEMPT TO STORE OR INJECT ACETYLENE GAS INTO ANY TYPE OF VESSEL, TANK, OR ENCLOSURE. IMPROPERLY STORED ACETYLENE GAS IS UNSTABLE.
- ACETYLENE GAS REGULATORS SHOULD NOT EXCEED A SETTING OF 15 P.S.I.G.
- FLAME ARRESTORS AND CHECK VALVES SHOULD BE INSTALLED AT BOTH THE TORCH BASE HOSE CONNECTIONS AND AT THE REGULATOR HOSE CONNECTIONS.
- ACETYLENE CYLINDERS SHOULD BE PROPERLY SECURED AT ALL TIMES. MOVEMENT OF CYLINDERS SHOULD BE DONE WITH CARE. CYLINDERS SHOULD BE PROTECTED FROM FLAME OR HEAT.

When exposed to excess temperature, pressure, or mechanical shock, pure or less than pure acetylene gas can undergo a violent, explosive decomposition reaction. Additionally, if this reaction, or an ignition of acetylene occurs within the torch base or supply hose, it can propagate back into the storage cylinder causing it to explode violently.

Flammable range: Acetylene has a very wide range of flammability. The lower flammable limit (LFL) is typically listed as 2.5% and the upper flammable limit (UFL) is listed as 81%. Although acetylene will not undergo combustion at concentrations above the UFL, it can undergo an explosive decomposition reaction, even at concentrations of 100%.

- NEVER USE ACETYLENE OR ITS EQUIPMENT IN ANY WAY NOT CONSISTANT WITH RECOGNIZED GOOD PRACTICE.
- ALWAYS MAINTAIN ACETYLENE CUTTING EQUIPMENT IN PROPER WORKING CONDITION TO PREVENT INADVERTANT LEAKAGE OF ACETYLENE OR OXYGEN INTO THE SURROUNDING WORK ENVIRONMENT.
- WHILE STORAGE IN A HORIZONTAL POSITION DOES NOT MAKE THE ACETYLENE LESS STABLE OR SAFE, IT DOES INCREASE THE LIKELIHOOD OF SOLVENT LOSS, WHICH WILL RESULT IN A LOWER FLAME QUALITY WHEN THE CYLINDER IS USED. THEREFORE IT IS ALWAYS PREFERABLE TO STORE AN ACETYLENE CYLINDER IN AN UPRIGHT POSITION.

Acetylene gas is ignitable over a wide range of concentrations.

Ease of ignition: Acetylene is a very easy gas to ignite. In fact, the energy from a static spark capable of igniting acetylene is lower than for any other fuel gas except hydrogen. The ignition energy of acetylene in air is approximately seventeen times lower than that of methane. The static charge developed by walking across a carpet floor on a dry day can be 1700 times greater than that needed to ignite acetylene. When mixed with pure oxygen, the ignition energy of acetylene is almost 100 times lower than it is in air.

- NEVER DISCHARGE UNBURNED ACETYLENE GAS FROM A TORCH EXCEPT FOR THE NORMAL PROCESS OF LIGHTING THE TORCH.
- NEVER DISCHARGE UNBURNED ACETYLENE GAS FROM A TORCH INTO ANY TYPE OF CONTAINER OR VESSEL.

When unburned acetylene gas is discharged from a torch, static electricity can be generated at the torch tip. If the tip comes in contact with a ground path, a static spark capable of igniting the acetylene can occur.

Rate of combustion reaction: Because of its simple chemical make up and sensitive triple bond, acetylene burns at a very fast rate. This very fast burning rate can accelerate the rate at which pressure is generated in an explosion beyond what would occur for other fuels. This, in turn, can make acetylene explosions more violent than for other fuels.

- NEVER DISCHARGE UNBURNED ACETYLENE GAS INTO ANY TYPE OF CONTAINER, VESSEL, ENCLOSURE, OR PIPE (SUCH AS A "POTATO GUN") WITH THE INTENT OF IGNITING THE GAS TO "DEMONSTRATE" THE HAZARDS OF ACETYLENE, OR TO PROPEL AN OBJECT FROM AN ENCLOSURE OR TUBE.

Because of the very fast reaction rate of burning acetylene, it is not generally possible to design an enclosure to safely vent the explosive pressures. Furthermore, because of the ease of ignition of acetylene, premature ignition is very possible.

AIR

Air is a mixture of gases and aerosols that composes the atmosphere surrounding Earth. The primary gases of air include nitrogen (78%) and oxygen (21%). Trace gases and aerosols make up the remaining 1% of air. The trace gases include the noble gases argon, neon, helium, krypton and xenon; hydrogen; and the greenhouse gases. The aerosols are solid or liquid particles having diameters in the region of 0.001 to 10 microns (millionth of a metre), and include dust, soot, sea salt crystals, spores, bacteria, viruses and a plethora of other microscopic particles, which may be natural or man-made.

Besides "air," which is made up of primarily/approximately 78% nitrogen and 21% oxygen, there are four main gases that concern workers in a coal mine. They are carbon dioxide (CO₂), carbon monoxide (CO), methane (CH₄), and hydrogen sulfide (H₂S). The levels and combinations of these gases along with the level of oxygen or "air" determine the danger and what they are known as.

What gases make up air?

A: Nitrogen - 78.09 %
Oxygen - 20.95%
Argon - .93%
Carbon Dioxide - .03%.
Neon - .0018%
Helium - .0005%
Krypton - .0001%
Hydrogen - .0005%
Xenon - .000008%
Ozone - .000002%
Radon - Traces

COAL

Coal is a combustible rock formed from the remains of decayed vegetation. It is the only rock containing significant amounts of elemental carbon. The composition of coal varies between 60% and 95% carbon. Coal also contains hydrogen and oxygen, with small concentrations of nitrogen, chlorine, sulfur, and several metals. Coals are classified by the amount of volatile material they contain, that is, by how much of the mass is vaporized when the coal is heated to about 900°C in the absence of air. Coal that contains more than 15% volatile material is called bituminous coal. Substances released from bituminous coal when it is distilled, in addition to methane, include water, carbon dioxide, ammonia, benzene, toluene, naphthalene, and anthracene. The non-volatile component of coal, which remains after distillation, is coke.

Types of Coal

Initially the peat is converted into lignite or 'brown coal' - these are coal-types with low organic maturity. In comparison to other coals, lignite is quite soft and its color can range from dark black to various shades of brown.

Over many more millions of years, the continuing effects of temperature and pressure produces further change in the lignite, progressively increasing its organic maturity and transforming it into the range known as 'sub-bituminous' coals.

Further chemical and physical changes occur until these coals became harder and blacker, forming the 'bituminous' or 'hard coals'. Under the right conditions, the progressive increase in the organic maturity can continue, finally forming anthracite.

In addition to carbon, coals contain hydrogen, oxygen, nitrogen and varying amounts of sulphur. High-rank coals are high in carbon and therefore heat value, but low in hydrogen and oxygen. Low-rank coals are low in carbon but high in hydrogen and oxygen content.

Different types of coal also have different uses, as shown in the diagram below.

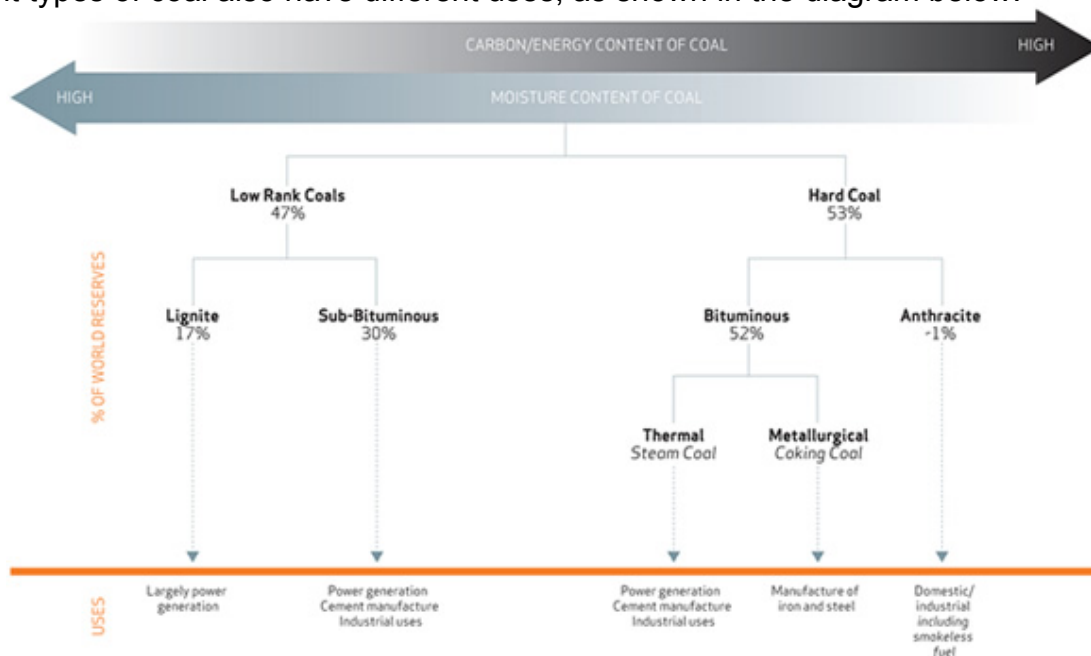

PROPERTIES OF MINE GASES

NAME OF GAS	CHEMICAL SYMBOL	SPECIFIC GRAVITY	COM-BUSTIBLE	EFFECT ON LIFE	SOURCE OR CAUSE WHERE FOUND	EXPLOSIVE RANGE PERCENT BY VOLUME	COMMON NAME	HOW DETECTED	COLOR-LESS	ODOR-LESS	TASTE-LESS
Air		1.000	Supports	Supports	Atmosphere	None					
Oxygen	O ₂	1.105	Supports	Supports	21% of atmosphere	None		O ₂ detector	X	X	X
Methane	CH ₄	.555	Yes	Inert	Coal & rock strata carbonaceous Shale, rotting mine timbers	5.0% - 15.0%	Marsh gas, fire damp	Methanometer	X	X	X
Carbon Dioxide	CO ₂	1.529	No	Poisonous in high concentration	Oxide of coal, blasting, mine fires, timber decay, diesel engines, breathing	None	Black damp	Colorimetric analysis	X	X	If high, slightly acid taste
Carbon Monoxide	CO	.967	Yes	Poisonous	Incomplete combustion, mine fires, explosions, blasting, diesel engines	12.5% - 74.0%	White damp	CO detector	X	X	X
Nitrogen	N ₂	.967	No	Inert	About 4/5 of atmosphere	None		Analysis	X	X	X
Hydrogen Sulfide	H ₂ S	1.191	Yes	Poisonous	Explosions, mine fires, blasting	4.3% - 45.0%		Hydrogen sulfide detector acetate of lead	X	Sulfur odor	X
Nitrogen Dioxide	NO ₂	1.503	No	Poisonous	Blasting, burning explosives, Burning nitrates, diesel exhaust	None		Analysis	Brownish red	If high, sharp sweet order	
Sulfur Dioxide	SO ₂	2.263	No	Poisonous	By burning Pyrites, some diesel fuels	None		Odor, Colorimetric analysis	X	Sulfur Odor	Acidic taste
Hydrogen	H ₂	.070	Yes	Inert	Charging batteries, mine fires, explosions, strong acids on metal	4.1% - 74.0%		Analysis	X	X	X
Acetylene	C ₂ H ₂	.907	Yes	Slightly poisonous	Formed when methane is burned, welding	2.5% - 80.0%		Odor	X	Garlic odor	X

OXYGEN DEFICIENCY

OXYGEN PRESENT EFFECT

21%	Breathing easiest
17%	Breathing faster and deeper
15%	Dizziness, buzzing noise, rapid pulse, headache, blurred vision
9%	May faint or become unconscious
6%	Movement convulsive, breathing stops, shortly after heart stops



Title 30

Code of Federal Regulation

30 CFR § 75.150

Tests for methane and for oxygen deficiency; qualified person.

(a) The provisions of Subpart D--Ventilation of this part and [§75.1106](#) require that tests for methane and for oxygen deficiency be made by a qualified person. A person is a qualified person for this purpose if he is a certified person under [§75.100](#).

(b) Pending issuance of Federal standards, a person will be considered a qualified person for testing for methane and for oxygen deficiency:

- (1) If he has been qualified for this purpose by the State in which the coal mine is located; or
- (2) The Secretary may qualify persons for this purpose in a coal mine in which persons are not qualified for this purpose by the State upon an application and a satisfactory showing by the operator of the coal mine that each such person has been trained and designated by the operator to test for methane and oxygen deficiency and has made such tests for a period of 6 months immediately preceding the application. Applications for Secretarial qualification should be submitted to the Health and Safety Activity, Mine Safety and Health Administration, Certification and Qualification Center, P.O. Box 25367, Denver Federal Center, Denver, Colo. 80225.

30 CFR § 75.321

Air quality.

(a) The air in areas where persons work or travel, except as specified in paragraph (a)(2) of this section, shall contain at least 19.5 percent oxygen and not more than 0.5 percent carbon dioxide, and the volume and velocity of the air current in these areas shall be sufficient to dilute, render harmless, and carry away flammable, explosive, noxious, and harmful gases, dusts, smoke, and fumes.

(2) The air in areas of bleeder entries and worked-out areas where persons work or travel shall contain at least 19.5 percent oxygen, and carbon dioxide levels shall not exceed 0.5 percent time weighted average and 3.0 percent short term exposure limit.

(b) Notwithstanding the provisions of [§75.322](#), for the purpose of preventing explosions from gases other than methane, the following gases shall not be permitted to accumulate in excess of the concentrations listed below:

- (1) Carbon monoxide (CO)--2.5 percent
- (2) Hydrogen (H₂)--.80 percent
- (3) Hydrogen sulfide (H₂S)--.80 percent
- (4) Acetylene (C₂H₂)--.40 percent
- (5) Propane (C₃H₈)--.40 percent
- (6) MAPP (methyl-acetylene-propylene-propodiene)--.30 percent

30 CFR § 75.323

Actions for excessive methane.

(a) *Location of tests.* Tests for methane concentrations under this section shall be made at least 12 inches from the roof, face, ribs, and floor.

(b) *Working places and intake air courses.*

(1) When 1.0 percent or more methane is present in a working place or an intake air course, including an air course in which a belt conveyor is located, or in an area where mechanized mining equipment is being installed or removed--

(i) Except intrinsically safe atmospheric monitoring systems (AMS), electrically powered equipment in the affected area shall be deenergized, and other mechanized equipment shall be shut off;

(ii) Changes or adjustments shall be made at once to the ventilation system to reduce the concentration of methane to less than 1.0 percent; and

(iii) No other work shall be permitted in the affected area until the methane concentration is less than 1.0 percent.

(2) When 1.5 percent or more methane is present in a working place or an intake air course, including an air course in which a belt conveyor is located, or in an area where mechanized mining equipment is being installed or removed--

(i) Everyone except those persons referred to in §104(c) of the Act shall be withdrawn from the affected area; and

(ii) Except for intrinsically safe AMS, electrically powered equipment in the affected area shall be disconnected at the power source.

(c) *Return air split.* (1) When 1.0 percent or more methane is present in a return air split between the last working place on a working section and where that split of air meets another split of air, or the location at which the split is used to ventilate seals or worked-out areas changes or adjustments shall be made at once to the ventilation system to reduce the concentration of methane in the return air to less than 1.0 percent.

(2) When 1.5 percent or more methane is present in a return air split between the last working place on a working section and where that split of air meets another split of air, or the location where the split is used to ventilate seals or worked-out areas--

(i) Everyone except those persons referred to in §104(c) of the Act shall be withdrawn from the affected area;

(ii) Other than intrinsically safe AMS, equipment in the affected area shall be deenergized, electric power shall be disconnected at the power source, and other mechanized equipment shall be shut off; and

(iii) No other work shall be permitted in the affected area until the methane concentration in the return air is less than 1.0 percent.

(d) *Return air split alternative.* (1) The provisions of this paragraph apply if--

(i) The quantity of air in the split ventilating the active workings is at least 27,000 cubic feet per minute in the last open crosscut or the quantity specified in the approved ventilation plan, whichever is greater;

(ii) The methane content of the air in the split is continuously monitored during mining operations by an AMS that gives a visual and audible signal on the working section when the methane in the return air reaches 1.5 percent, and the methane content is monitored as specified in [§75.351](#); and

(iii) Rock dust is continuously applied with a mechanical duster to the return air course during coal production at a location in the air course immediately outby the most inby monitoring point.

(2) When 1.5 percent or more methane is present in a return air split between a point in the

return opposite the section loading point and where that split of air meets another split of air or where the split of air is used to ventilate seals or worked-out areas--

(i) Changes or adjustments shall be made at once to the ventilation system to reduce the concentration of methane in the return air below 1.5 percent;

(ii) Everyone except those persons referred to in §104(c) of the Act shall be withdrawn from the affected area;

(iii) Except for intrinsically safe AMS, equipment in the affected area shall be deenergized, electric power shall be disconnected at the power source, and other mechanized equipment shall be shut off; and

(iv) No other work shall be permitted in the affected area until the methane concentration in the return air is less than 1.5 percent.

(e) *Bleeders and other return air courses.* The concentration of methane in a bleeder split of air immediately before the air in the split joins another split of air, or in a return air course other than as described in paragraphs (c) and (d) of this section, shall not exceed 2.0 percent.

30 CFR § 75.342 Methane monitors.

(a)(1) MSHA approved methane monitors shall be installed on all face cutting machines, continuous miners, longwall face equipment, loading machines, and other mechanized equipment used to extract or load coal within the working place.

(2) The sensing device for methane monitors on longwall shearing machines shall be installed at the return air end of the longwall face. An additional sensing device also shall be installed on the longwall shearing machine, downwind and as close to the cutting head as practicable. An alternative location or locations for the sensing device required on the longwall shearing machine may be approved in the ventilation plan.

(3) The sensing devices of methane monitors shall be installed as close to the working face as practicable.

(4) Methane monitors shall be maintained in permissible and proper operating condition and shall be calibrated with a known air-methane mixture at least once every 31 days. To assure that methane monitors are properly maintained and calibrated, the operator shall:

(i) Use persons properly trained in the maintenance, calibration, and permissibility of methane monitors to calibrate and maintain the devices.

(ii) Maintain a record of all calibration tests of methane monitors. Records shall be maintained in a secure book that is not susceptible to alteration or electronically in a computer system so as to be secure and not susceptible to alteration.

(iii) Retain the record of calibration tests for 1 year from the date of the test. Records shall be retained at a surface location at the mine and made available for inspection by authorized representatives of the Secretary and the representative of miners.

(b)(1) When the methane concentration at any methane monitor reaches 1.0 percent the monitor shall give a warning signal.

(2) The warning signal device of the methane monitor shall be visible to a person who can deenergize electric equipment or shut down diesel-powered equipment on which the monitor is mounted.

(c) The methane monitor shall automatically deenergize electric equipment or shut down diesel-powered equipment on which it is mounted when--

(1) The methane concentration at any methane monitor reaches 2.0 percent; or

(2) The monitor is not operating properly.

MINES GASES

Questions for Review

Q: What gases make up the air we breathe?

Q: What are the sources of methane in coal mines?

Q: What other gas must be present in order for methane to explode (when CH₄ content is between 5% - 15%)

Q: What is the lowest level of Oxygen that will support life?

Q: Why are small quantities of Carbon Monoxide injurious?

Q: How is Carbon Dioxide formed in a coal mine?

Q: What four gases are required (by CFR Part 75) to be monitored?

Q: What element in air is essential for life?

Q: What is the explosive range for Hydrogen Sulfide?

Q: What is the most violent explosive point for methane?

Q: What are some of the uses of Nitrogen?

Q: Is Sulfur Dioxide combustible?

Q: Is Hydrogen explosive?

Q: What are some of the effects of breathing in Hydrogen Sulfide?

Q: What effect does Carbon Dioxide have upon life?

Q: At what level would someone begin to feel the effects of Carbon Monoxide exposure?

Q: Where would Hydrogen Sulfide tend to accumulate in a coal mine?

Q: What are some of the hazards posed to humans by Hydrogen?

Q: What are some of the effects of inhaling Sulfur Dioxide?

Q: How can you detect Nitrogen Dioxide?

CHAPTER TWO

FIRES AND EXPLOSIONS

1. Historical Mine Disasters
2. Fire Classifications
3. Mining Terms for Explosive Mixtures
4. Code of Federal Regulations Part 75
5. Questions and Review

FIRES



Fires are a significant hazard to the safety and health of mine workers. Fires at underground and surface mines place the lives and livelihood of our nation's miners at risk. Ventilation streams in underground mines can carry smoke and toxic combustion products throughout the mine, making escape through miles of confined passageways difficult and time consuming. A fire in an underground coal mine is especially hazardous due to the unlimited fuel supply and the presence of flammable methane gas. The greatest mine fire disaster in the US occurred at the Cherry Coal Mine, IL, in November 1909, where 259 miners perished. During 1990-2001, more than 975 reportable fires occurred in the US mining industry, causing over 470 injuries, 6 fatalities, and the temporary closing of several mines. Over 95 of the fires occurred in underground coal mines. The leading causes of mine fires include flame cutting and welding operations, friction, electrical shorts, mobile equipment malfunctions, and spontaneous combustion. Several recent large coal mine fires have resulted in mine evacuations and temporary sealing of the mines. The prevention, early and reliable detection, control, and suppression of mine fires are critical elements in safeguarding the lives and livelihood of over 230,000 mine workers.

Information for historical mine fires was obtained from the following publications/websites:

- **NIOSH Office of Mine Safety and Health Research**

Coal Mining Disasters

(Incidents with 5 or more fatalities)

From 1980 - 2010

<u>Date</u>	<u>Mine Name</u>	<u>City</u>	<u>State</u>	<u>Killed</u>	<u>Product</u>	<u>Type</u>
11/07/1980	Ferrell No. 17	Uneeda	WV	5	Coal	Explosion
04/15/1981	Mid-Continent Resources Dutch Creek #1	Redstone	CO	15	Coal	Explosion
12/07/1981	Adkins Coal Mine #11	Kite	KY	8	Coal	Explosion
12/08/1981	Grundy Mining Co. Mine #21	Whitewell	TN	13	Coal	Explosion
01/20/1982	No. 1	Craynor	KY	7	Coal	Explosion
06/21/1983	McClure #1 Mine	McClure	VA	7	Coal	Explosion
12/19/1984	Wilberg Mine	Orangeville	UT	27	Coal	Fire
02/06/1986	Loveridge No. 22	Fairview	WV	5	Coal	Collapsed coal pile caused suffocation
09/13/1989	William Station No. 9 Mine	Wheatcroft	KY	10	Coal	Explosion
12/07/1992	No. 3 Mine	Norton	VA	8	Coal	Explosion
09/23/2001	No. 5 Mine	Brookwood	AL	13	Coal	Explosion
01/02/2006	Sago Mine	Buckhannon	WV	12	Coal	Explosion
05/20/2006	Darby Mine No. 1	Millsboro	KY	5	Coal	Explosion
08/06/2007	Crandall Canyon Mine	Huntington	UT	6**	Coal	Fall of face or rib
04/05/2010	Upper Big Branch Mine	Montcoal	WV	29	Coal	Explosion

** Subsequent incident occurred 8/16/2007 during the rescue efforts that claimed the lives of three rescue workers (including one MSHA employee).

Information for historical mine disasters was obtained from the following publications:

- Bureau of Mines Bulletin 509, Injury Experience in Coal Mining, 1948
- Bureau of Mines Bulletin 616, Historical Documentation of Major Coal-Mine Disasters in the United States Not Classified as Explosions of Gas or Dust: 1846-1962
- Bureau of Mines Bulletin 586; Historical Summary of Coal-Mine Explosions in the United States, 1810-1958
- Historical Summary of Mine Disasters in the United States, Volume I, Coal Mines, 1810-1958
- Historical Summary of Mine Disasters in the United States, Volume II, Coal Mines, 1959-1998
- 1998-present, MSHA Fatalgrams and Fatality Reports
- Newspaper article citations when available
- Archives at the National Mine Health & Safety Academy Library, Beckley, West Virginia

Historical accident reports are available in the library archives at the National Mine Health & Safety Academy in Beckley, West Virginia. Please contact the MSHA Academy at 304-256-3266 or MSHAlibrary@dol.gov to check on the availability of a particular report.

FIRE CLASSES

In firefighting, fires are identified according to one or more **fire classes**. Each class designates the fuel involved in the fire, and thus the most appropriate extinguishing agent. The classifications allow selection of extinguishing agents along lines of effectiveness at putting the type of fire out, as well as avoiding unwanted side-effects. For example, non-conductive extinguishing agents are rated for electrical fires, so to avoid electrocuting the firefighter.

Multiple classification systems exist, with different designations for the various classes of fire. The United States uses the NFPA system. Europe and Australasia use another.

United States – NFPA system		
		Fuel/Heat source
Class A		Ordinary combustibles
Class B		Flammable liquids
		Flammable gases
Class C		Electrical equipment
Class D		Combustible metals
Class K		Cooking oil or fat

Ordinary combustibles

"Ordinary combustible" fires are the most common type of fire, and are designated *Class A*. These occur when a solid, organic material such as wood, cloth, rubber, or some plastics become heated to their flash point and ignite. At this point the material

undergoes combustion and will continue burning as long as the four components of the fire tetrahedron (heat, fuel, oxygen, and the sustaining chemical reaction) are available.

This class of fire is commonly used in controlled circumstances, such as a campfire, match or wood-burning stove. To use the campfire as an example, it has a fire tetrahedron - the heat is provided by another fire (such as a match or lighter), the fuel is the wood, the oxygen is naturally available in the open-air environment of a forest, and the chemical reaction links the three other facets. This fire is not dangerous, because the fire is contained to the wood alone and is usually isolated from other flammable materials, for example by bare ground and rocks. However, when a class-A fire burns in a less-restricted environment the fire can quickly grow out of control and become a wildfire.

This class of fire is fairly simple to fight and contain - by simply removing the heat, oxygen, or fuel, or by suppressing the underlying chemical reaction, the fire tetrahedron collapses and the fire dies out. The most common way to do this is by removing heat by spraying the burning material with water; oxygen can be removed by smothering the fire with foam from a fire extinguisher; forest fires are often fought by removing fuel by backburning; and an ammonium phosphate dry chemical powder fire extinguisher (but not sodium bicarbonate or potassium bicarbonate both of which are rated for B-class fires) breaks the fire's underlying chemical reaction.

Flammable liquid and gas

Flammable or combustible liquid or gaseous fuels. The US system designates all such fires "Class B". These fires follow the same basic fire tetrahedron (heat, fuel, oxygen, chemical reaction) as ordinary combustible fires, except that the fuel in question is a flammable liquid such as gasoline, or gas such as natural gas. A solid stream of water should never be used to extinguish this type because it can cause the fuel to scatter, spreading the flames. The most effective way to extinguish a liquid or gas fueled fire is by inhibiting the chemical chain reaction of the fire, which is done by dry chemical and Halon extinguishing agents, although smothering with CO₂ or, for liquids, foam is also effective. Chemicals such as FM-200 are now the recommended halogenated suppressant.

Electrical

Electrical fires are fires involving potentially energized electrical equipment. The US system designates these "Class C". This sort of fire may be caused by, for example, short-circuiting machinery or overloaded electrical cables. These fires can be a severe hazard to firefighters using water or other conductive agents: Electricity may be conducted from the fire, through water, the firefighter's body, and then earth. Electrical shocks have caused many firefighter deaths.

Electrical fire may be fought in the same way as an ordinary combustible fire, but water, foam, and other conductive agents are not to be used. While the fire is, or could possibly be electrically energized, it can be fought with any extinguishing agent rated for electrical fire. Carbon dioxide CO₂, FM-200 and dry chemical powder extinguishers such as PKP and even baking soda are especially suited to extinguishing this sort of fire. Once

electricity is shut off to the equipment involved, it will generally become an ordinary combustible fire.

Metal

Certain metals are flammable or combustible. Fires involving such are designated "Class D" in both systems. Examples of such metals include sodium, titanium, magnesium, potassium, steel, uranium, lithium, plutonium, and calcium. Magnesium and titanium fires are common, and 2006-7 saw the recall of laptop computer models containing lithium batteries susceptible to spontaneous ignition. When one of these combustible metals ignites, it can easily and rapidly spread to surrounding ordinary combustible materials.

With the exception of the metals that burn in contact with air or water (for example, sodium), masses of combustible metals do not represent unusual fire risks because they have the ability to conduct heat away from hot spots so efficiently that the heat of combustion cannot be maintained - this means that it will require a lot of heat to ignite a mass of combustible metal. Generally, metal fire risks exist when sawdust, machine shavings and other metal 'fines' are present. Generally, these fires can be ignited by the same types of ignition sources that would start other common fires.

Water and other common firefighting materials can excite metal fires and make them worse. The NFPA recommends that metal fires be fought with 'dry powder' extinguishing agents. Dry Powder agents work by smothering and heat absorption. The most common of these agents are sodium chloride granules and graphite powder. In recent years powdered copper has also come into use.

Some extinguishers are labeled as containing *dry chemical* extinguishing agents. This may be confused with *dry powder*. The two are not the same. Using one of these extinguishers in error, in place of dry powder, can be ineffective or actually increase the intensity of a metal fire.

Metal fires represent a unique hazard because people are often not aware of the characteristics of these fires and are not properly prepared to fight them. Therefore, even a small metal fire can spread and become a larger fire in the surrounding ordinary combustible materials.

Cooking oil

Laboratory simulation of a chip pan fire: a beaker containing wax is heated until it catches fire. A small amount of water is then poured into the beaker. The water sinks to the bottom and vaporises instantly, ejecting a plume of burning liquid wax into the air.

Fires that involve cooking oils or fats are designated "Class K" under the US system. Though such fires are technically a subclass of the flammable liquid/gas class, the special characteristics of these types of fires are considered important enough to recognize separately. Saponification can be used to extinguish such fires. Appropriate fire extinguishers may also have hoods over them that help extinguish the fire.

MINING TERMS FOR EXPLOSIVE MIXTURES

Fire Damp

Made up mainly by methane, an inflammable gas which when mixed with the right proportion of oxygen, can be explosive, fire damp is also quite dangerous in a coal mine. Methane, which makes up between 90% and 100% of the inflammable part of fire damp (generally around 70% to 80% of the "air," when the nonflammable gases are accounted for). Like carbon monoxide, it is lighter than air. It is a product of the mine, itself, being given off when it is released from the rock where it was trapped ages ago (methane is, like coal, a product of decomposition of organic matter). When the rock is removed or a seam is opened or cracked, methane can escape.

Besides the danger of the gas through fire/explosion and breathing it in (while not poisonous, it cannot support life, having no oxygen as part of the molecule—fire damp has very little oxygen, anyway), the gas trapped within the rock can have built up enormous pressure that when released, can cause injury and even death when the rock flies into the miner.

Depending on the amount of oxygen and the percentage of methane, the mixture can be merely inflammable (where the gas will continue to burn on its own after the ignition source is removed) or explosive. At inflammable levels, rather than exploding, the methane will burn around the ignition source in a sort of halo effect, known as a "cap."

In addition to methane, fire damp may also have small amounts of ethane and/or propane (anywhere from 0% to 2%)—both of which are more inflammable and ignite at a lower temperature). In an important way, the degree of other gases present affects the ignition temperature; higher or lower depending on the gas and the percentage present in the air. Another gas, sometimes found in trace amounts, is ethylene, another highly inflammable gas. Despite the low percentages of each, their presence makes fire damp even more volatile and liable to explode, than methane alone.

After Damp

The combination of gases remaining following an explosion (whether due to "fire damp" or to coal dust—which in fine quantities can result in an explosion under the right conditions). It varies depending on the amount of oxygen that was present as part of the explosion. If methane in the explosion combusts completely, it will produce carbon dioxide and steam. This will leave a form of "black damp." If there is less oxygen, there will be additional amounts of carbon monoxide and hydrogen mixed with the aforementioned gases. This will result if there is either greater amounts of methane or smaller amounts of oxygen.

After damp is particularly dangerous, as carbon monoxide is poisonous, carbon dioxide can cause suffocation, and free oxygen will be necessarily depleted. A further danger is that if air is re-added to the mixture, it can become explosive again (not an unheard of occurrence). According to my source (www.therhondda.co.uk), over 75% of deaths in coal mine explosions in Great Britain were caused by "after-damp alone." The main reason being the carbon monoxide in it. There can be many other gases found in after damp, following the explosion, including hydrogen sulfide, sulfur dioxide, nitrous oxide, ammonia, and others.

Black Damp

Also known as "choke damp" or "stythe," it is when levels of carbon dioxide are high and mixed with nitrogen (taking the place of free oxygen). These levels can be from 5% to 20%. My source gives around 13% as an average carbon dioxide level in black damp (15% and higher will put out a flame). While at the low end of the scale it is about the same density as air, as the percentage increases, so does the density, making black damp especially dangerous the lower the level in a mine one is working (workers would sometimes hold their lights near the floor to aid in detection).

Black damp is neither combustible nor poisonous, by itself, but enough in the air mixture can lead to physical effects or even death by suffocation.

White Damp

White Damp is a mining term for, carbon monoxide (CO); a gas that may be present in the afterdamp of a gas or coal-dust explosion, or in the gases given off by a mine fire; it is an important constituent of illuminating gas, supports combustion, and is very poisonous.



Title 30

Code of Federal Regulation

30 CFR § 75.321 **Air quality.**

(a) The air in areas where persons work or travel, except as specified in paragraph (a)(2) of this section, shall contain at least 19.5 percent oxygen and not more than 0.5 percent carbon dioxide, and the volume and velocity of the air current in these areas shall be sufficient to dilute, render harmless, and carry away flammable, explosive, noxious, and harmful gases, dusts, smoke, and fumes.

(2) The air in areas of bleeder entries and worked-out areas where persons work or travel shall contain at least 19.5 percent oxygen, and carbon dioxide levels shall not exceed 0.5 percent time weighted average and 3.0 percent short term exposure limit.

(b) Notwithstanding the provisions of [§75.322](#), for the purpose of preventing explosions from gases other than methane, the following gases shall not be permitted to accumulate in excess of the concentrations listed below:

- (1) Carbon monoxide (CO)--2.5 percent
- (2) Hydrogen (H₂)--.80 percent
- (3) Hydrogen sulfide (H₂S)--.80 percent
- (4) Acetylene (C₂H₂)--.40 percent
- (5) Propane (C₃H₈)--.40 percent
- (6) MAPP (methyl-acetylene-propylene-propodiene)--.30 percent

30 CFR § 75.322 **Harmful quantities of noxious gases.**

Concentrations of noxious or poisonous gases, other than carbon dioxide, shall not exceed the threshold limit values (TLV) as specified and applied by the American Conference of Governmental Industrial Hygienists in "Threshold Limit Values for Substance in Workroom Air" (1972). Detectors or laboratory analysis of mine air samples shall be used to determine the concentrations of harmful, noxious, or poisonous gases. This incorporation by reference has been approved by the Director of the Federal Register in accordance with 5 U.S.C. 552(a) and 1 CFR part 51. Copies are available from the Mine Safety and Health Administration, Department of Labor, 1100 Wilson Boulevard, Room 2424, Arlington, VA 22209-3939 and at every MSHA Coal Mine Safety and Health district

office. The material is available for examination at the Office of the Federal Register, 800 N. Capitol Street, NW., 7th Floor, suite 700, Washington, DC.

30 CFR § 75.323

Actions for excessive methane.

(a) *Location of tests.* Tests for methane concentrations under this section shall be made at least 12 inches from the roof, face, ribs, and floor.

(b) *Working places and intake air courses.*

(1) When 1.0 percent or more methane is present in a working place or an intake air course, including an air course in which a belt conveyor is located, or in an area where mechanized mining equipment is being installed or removed--

(i) Except intrinsically safe atmospheric monitoring systems (AMS), electrically powered equipment in the affected area shall be deenergized, and other mechanized equipment shall be shut off;

(ii) Changes or adjustments shall be made at once to the ventilation system to reduce the concentration of methane to less than 1.0 percent; and

(iii) No other work shall be permitted in the affected area until the methane concentration is less than 1.0 percent.

(2) When 1.5 percent or more methane is present in a working place or an intake air course, including an air course in which a belt conveyor is located, or in an area where mechanized mining equipment is being installed or removed--

(i) Everyone except those persons referred to in §104(c) of the Act shall be withdrawn from the affected area; and

(ii) Except for intrinsically safe AMS, electrically powered equipment in the affected area shall be disconnected at the power source.

(c) *Return air split.* (1) When 1.0 percent or more methane is present in a return air split between the last working place on a working section and where that split of air meets another split of air, or the location at which the split is used to ventilate seals or worked-out areas changes or adjustments shall be made at once to the ventilation system to reduce the concentration of methane in the return air to less than 1.0 percent.

(2) When 1.5 percent or more methane is present in a return air split between the last working place on a working section and where that split of air meets another split of air, or the location where the split is used to ventilate seals or worked-out areas--

(i) Everyone except those persons referred to in §104(c) of the Act shall be withdrawn from the affected area;

(ii) Other than intrinsically safe AMS, equipment in the affected area shall be deenergized, electric power shall be disconnected at the power source, and other

mechanized equipment shall be shut off; and

(iii) No other work shall be permitted in the affected area until the methane concentration in the return air is less than 1.0 percent.

(d) *Return air split alternative.* (1) The provisions of this paragraph apply if--

(i) The quantity of air in the split ventilating the active workings is at least 27,000 cubic feet per minute in the last open crosscut or the quantity specified in the approved ventilation plan, whichever is greater;

(ii) The methane content of the air in the split is continuously monitored during mining operations by an AMS that gives a visual and audible signal on the working section when the methane in the return air reaches 1.5 percent, and the methane content is monitored as specified in [§75.351](#); and

(iii) Rock dust is continuously applied with a mechanical duster to the return air course during coal production at a location in the air course immediately outby the most inby monitoring point.

(2) When 1.5 percent or more methane is present in a return air split between a point in the return opposite the section loading point and where that split of air meets another split of air or where the split of air is used to ventilate seals or worked-out areas--

(i) Changes or adjustments shall be made at once to the ventilation system to reduce the concentration of methane in the return air below 1.5 percent;

(ii) Everyone except those persons referred to in §104(c) of the Act shall be withdrawn from the affected area;

(iii) Except for intrinsically safe AMS, equipment in the affected area shall be deenergized, electric power shall be disconnected at the power source, and other mechanized equipment shall be shut off; and

(iv) No other work shall be permitted in the affected area until the methane concentration in the return air is less than 1.5 percent.

(e) *Bleeders and other return air courses.* The concentration of methane in a bleeder split of air immediately before the air in the split joins another split of air, or in a return air course other than as described in paragraphs (c) and (d) of this section, shall not exceed 2.0 percent.

30 CFR § 75.400

Accumulation of combustible materials.

Coal dust, including float coal dust deposited on rock-dusted surfaces, loose coal, and other combustible materials, shall be cleaned up and not be permitted to accumulate in active workings, or on diesel- powered and electric equipment therein.

30 CFR § 75.401

Abatement of dust; water or water with a wetting agent.

[STATUTORY PROVISION]

Where underground mining operations in active workings create or raise excessive amounts of dust, water or water with a wetting agent added to it, or other no less effective methods approved by the Secretary or his authorized representative, shall be used to abate such dust. In working places, particularly in distances less than 40 feet from the face, water, with or without a wetting agent, or other no less effective methods approved by the Secretary or his authorized representative, shall be applied to coal dust on the ribs, roof, and floor to reduce dispersibility and to minimize the explosion hazard.

30 CFR § 75.402

Rock dusting.

[STATUTORY PROVISION]

All underground areas of a coal mine, except those areas in which the dust is too wet or too high in incombustible content to propagate an explosion, shall be rock dusted to within 40 feet of all working faces, unless such areas are inaccessible or unsafe to enter or unless the Secretary or his authorized representative permits an exception upon his finding that such exception will not pose a hazard to the miners. All crosscuts that are less than 40 feet from a working face shall also be rock dusted.

30 CFR § 75.403

Maintenance of incombustible content of rock dust.

Where rock dust is required to be applied, it shall be distributed upon the top, floor, and sides of all underground areas of a coal mine and maintained in such quantities that the incombustible content of the combined coal dust, rock dust, and other dust shall be not less than 80 percent. Where methane is present in any ventilating current, the percent of incombustible content of such combined dust shall be increased 0.4 percent for each 0.1 percent of methane.

30 CFR § 75.403-1

Incombustible content.

Moisture contained in the combined coal dust, rock dust and other dusts shall be considered as a part of the incombustible content of such mixture.

30 CFR § 75.1100

Requirements

[STATUTORY PROVISION]

Each coal mine shall be provided with suitable firefighting equipment adapted for the size and conditions of the mine. The Secretary shall establish minimum requirements of the type, quality, and quantity of such equipment.

30 CFR § 75.1100-1

Type and quality of firefighting equipment.

Firefighting equipment required under this subpart shall meet the following minimum requirements:

(a) Waterlines: Waterlines shall be capable of delivering 50 gallons of water a minute at a nozzle pressure of 50 pounds per square inch.

(b) Portable water cars: A portable water car shall be of at least 1,000 gallons capacity (500 gallons capacity for anthracite mines) and shall have at least 300 feet of fire hose with nozzles. A portable water car shall be capable of providing a flow through the hose of 50 gallons of water per minute at a nozzle pressure of 50 pounds per square inch.

(c) A portable chemical car shall carry enough chemicals to provide a fire extinguishing capacity equivalent to that of a portable water car.

(d) Portable foam-generating machines or devices: A portable foam-generating machine or device shall have facilities and equipment for supplying the machine with 30 gallons of water per minute at 30 pounds per square inch for a period of 35 minutes.

(e) Portable fire extinguisher: A portable fire extinguisher shall be either (1) a multipurpose dry chemical type containing a nominal weight of 5 pounds of dry powder and enough expellant to apply the powder or (2) a foam-producing type containing at least 2 1/2 gallons of foam-producing liquids and enough expellant to supply the foam. Only fire extinguishers approved by the Underwriters Laboratories, Inc., or Factory Mutual Research Corp., carrying appropriate labels as to type and purpose, shall be used. After March 30, 1971, all new portable fire extinguishers acquired for use in a coal mine shall have a 2A 10 BC or higher rating.

(f)(1) Except as provided in paragraph (f)(2) of this section, the fire hose shall be lined with a material having flame resistant qualities meeting requirements for hose in Bureau of Mines' Schedule 2G. The cover shall be polyester, or other material with flame-spread qualities and mildew resistance equal or superior to polyester. The bursting pressure shall be at least 4 times the water pressure at the valve to the hose inlet with the valve closed; the maximum water pressure in the hose nozzle shall not exceed 100 p.s.i.g.

(2) Fire hose installed for use in underground coal mines prior to December 30, 1970, shall be mildew-proof and have a bursting pressure at least 4 times the water pressure at the valve to the hose inlet with the valve closed, and the maximum water pressure in the hose nozzle with water flowing shall not exceed 100 p.s.i.g.

30 CFR § 75.1100-2

Quantity and location of firefighting equipment.

(a) *Working sections.* (1) Each working section of coal mines producing 300 tons or more per shift shall be provided with two portable fire extinguishers and 240 pounds of rock dust in bags or other suitable containers; waterlines shall extend to each section loading point and be equipped with enough fire hose to reach each working face unless the section loading point is provided with one of the following:

(i) Two portable water cars; or

(ii) Two portable chemical cars; or

(iii) One portable water car or one portable chemical car, and either (a) a portable foam-generating machine or (b) a portable high-pressure rock-dusting machine fitted with at least 250 feet of hose and supplied with at least 60 sacks of rock dust.

(2) Each working section of coal mines producing less than 300 tons of coal per shift shall be provided with the following:

(i) Two portable fire extinguishers; and

(ii) 240 pounds of rock dust in bags or other suitable containers; and

(iii) At least 500 gallons of water and at least three pails of 10- quart capacity; or a waterline with sufficient hose to reach the working places; or a portable water car of at least 500-gallons capacity; or a portable, all-purpose, dry-powder chemical car of at least 125-pounds capacity.

(3) As an alternative to paragraph (a)(2) of this section, each working section with no electrical equipment at the face of an anthracite coal mine producing less than 300 tons of coal per shift shall be provided with the following:

(i) Portable fire extinguishers containing a total capacity of at least 30 pounds of dry chemical or 15 gallons of foam and located at the entrance to the gangway at the bottom of the slope; and

(ii) Portable fire extinguishers containing a total capacity of at least 20 pounds of dry chemical or 10 gallons of foam and located within 500 feet from the working face.

(b) *Belt conveyors.* In all coal mines, waterlines shall be installed parallel to the entire length of belt conveyors and shall be equipped with firehose outlets with valves at 300-foot intervals along each belt conveyor and at tailpieces. At least 500 feet of firehose with fittings suitable for connection with each belt conveyor waterline system shall be stored at strategic locations along the belt conveyor. Waterlines may be installed in entries adjacent to the conveyor entry belt as long as the outlets project into the belt conveyor entry.

(c) *Haulage tracks.* (1) In mines producing 300 tons of coal or more per shift waterlines shall be installed parallel to all haulage tracks using mechanized equipment in the track or adjacent entry and shall extend to the loading point of each working section. Waterlines shall be equipped with outlet valves at intervals of not more than 500 feet, and 500 feet of firehose with fittings suitable for connection with such waterlines shall be provided at strategic locations. Two portable water cars, readily available, may be used in lieu of waterlines prescribed under this paragraph.

(2) In mines producing less than 300 tons of coal per shift, there shall be provided at 500-foot intervals in all main and secondary haulage roads:

(i) A tank of water of at least 55-gallon capacity with at least 3 pails of not less than 10-quart capacity; or

(ii) Not less than 240 pounds of bagged rock dust. (d) *Transportation*. Each track or off-track locomotive, self-propelled man-trip car, or personnel carrier shall be equipped with one portable fire extinguisher.

(e) *Electrical installations*. At each electrical installation, the operator shall provide two portable fire extinguishers that have a nominal capacity of 5 pounds of dry chemical, or one extinguisher that has a nominal capacity of at least 10 pounds of dry chemical, and which have a 2-A:10-B:C or higher rating.

(2) One portable fire extinguisher and 240 pounds of rock dust shall be provided at each temporary electrical installation.

(f) *Oil storage stations*. Two portable fire extinguishers and 240 pounds of rock dust, shall be provided at each permanent underground oil storage station. One portable fire extinguisher shall be provided at each working section where 25 gallons or more of oil are stored in addition to extinguishers required under paragraph (a) of this section.

(g) *Welding, cutting, soldering*. One portable fire extinguisher or 240 pounds of rock dust shall be provided at locations where welding, cutting, or soldering with arc or flame is being done.

(h) *Powerlines*. At each wooden door through which powerlines pass there shall be one portable fire extinguisher or 240 pounds of rock dust within 25 feet of the door on the intake air side.

(i) *Emergency materials*. (1) At each mine producing 300 tons of coal or more per shift there shall be readily available the following materials at locations not exceeding 2 miles from each working section:

1,000 board feet of brattice boards

2 rolls of brattice cloth

2 hand saws

25 pounds of 8(super)d nails

25 pounds of 10(super)d nails

25 pounds of 16(super)d nails

3 claw hammers

25 bags of wood fiber plaster or 10 bags of cement (or equivalent material for stoppings)

5 tons of rock dust

(2) At each mine producing less than 300 tons of coal per shift the above materials shall be available at the mine, provided, however, that the emergency materials for one or more mines may be stored at a central warehouse or building supply company and such supply must be the equivalent of that required for all mines involved and within 1-hour's delivery time from each mine. This exception shall not apply where the active working sections are more than 2 miles from the surface.

30 CFR § 75.1100-3

Condition and examination of firefighting equipment.

All firefighting equipment shall be maintained in a usable and operative condition. Chemical extinguishers shall be examined every 6 months and the date of the examination shall be written on a permanent tag attached to the extinguisher.

30 CFR § 75.1101-7

Installation of water sprinkler systems; requirements.

(a) The fire-control components of each water sprinkler system shall be installed, as far as practicable in accordance with the recommendations set forth in National Fire Protection Association 1968-69 edition, Code No. 13, "Installation of Sprinkler Systems" and such systems' components shall be of a type approved by the Underwriters' Laboratories, Inc., Factory Mutual Research Corp.

(b) Each sprinkler system shall provide protection for the motor drive belt takeup, electrical controls, gear reducing unit, and the 50 feet of fire-resistant belt, or 150 feet of nonfire-resistant belt adjacent to the belt drive.

(c) The components of each water sprinkler system shall be located so as to minimize the possibility of damage by roof fall or by the moving belt and its load.

30 CFR § 75.1103-8

Automatic fire sensor and warning device systems; examination and test requirements.

(a) Automatic fire sensor and warning device systems shall be examined at least once each shift when belts are operated as part of a production shift. A functional test of the warning signals shall be made at least once every seven days. Examination and maintenance of such systems shall be by a qualified person.

(b) A record of the functional test conducted in accordance with paragraph (a) of this section shall be maintained by the operator and kept for a period of one year.

(c) Sensors shall be calibrated in accordance with the manufacturer's calibration instructions at intervals not to exceed 31 days. A record of the sensor calibrations shall be maintained by the operator and kept for a period of one year.

30 CFR § 75.1103-9

Minimum requirements; fire suppression materials and location; maintenance of entries and crosscuts; access doors; communications; fire crews; high-expansion foam devices.

(a) The following materials shall be stored within 300 feet of each belt drive or at a location where the material can be moved to the belt drive within 5 minutes, except that when the ventilating current in the belt haulageway travels in the direction of the normal movement of coal on the belt, the materials shall be stored within 300 feet of the belt tailpiece or at a location where the materials can be moved to the belt tailpiece within 5 minutes.

(1) 500 feet of fire hose, except that if the belt flight is less than 500 feet in length the fire hose may be equal to the length of the belt flight. A high expansion foam device may be substituted for 300 feet of the 500 feet of the fire hose. Where used, such foam generators shall produce foam sufficient to fill 100 feet of the belt haulageway in not more than 5 minutes. Sufficient power cable and water hose shall be provided so that the foam generator can be installed at any crosscut along the belt by which the generator is located. A 1-hour supply of foam producing chemicals and tools and hardware required for its operation shall be stored at the foam generator.

(2) Tools to open a stopping between the belt entry and the adjacent intake entry; and

(3) 240 pounds of bagged rock dust.

(b) The entry containing the main waterline and the crosscuts containing water outlets between such entry and the belt haulageway (if the main waterline is in an adjacent entry) shall be maintained accessible and in safe condition for travel and firefighting activities. Each stopping in such crosscuts or adjacent crosscuts shall have an access door.

(c) Suitable communication lines extending to the surface shall be provided in the belt haulageway or adjacent entry.

(d) The fire suppression system required at the belt drive shall include the belt discharge head.

(e) A crew consisting of at least five members for each working shift shall be trained in firefighting operations. Fire drills shall be held at intervals not exceeding 6 months.

30 CFR § 75.1103-11

Tests of fire hydrants and fire hose; record of tests.

Each fire hydrant shall be tested by opening to insure that it is in operating condition, and each fire hose shall be tested, at intervals not exceeding 1 year. A record of these tests shall be maintained at an appropriate location.

30 CFR § 75.1106

Welding, cutting, or soldering with arc or flame underground.

[STATUTORY PROVISIONS]

All welding, cutting, or soldering with arc or flame in all underground areas of a coal mine shall, whenever practicable, be conducted in fireproof enclosures. Welding, cutting, or soldering with arc or flame in other than a fireproof enclosure shall be done under the supervision of a qualified person who shall make a diligent search for fire during and after such operations and shall, immediately before and during such operations, continuously test for methane with means approved by the Secretary for detecting methane. Welding, cutting, or soldering shall not be conducted in air that contains 1.0 volume per centum or more of methane. Rock dust or suitable fire extinguishers shall be immediately available during such welding, cutting or soldering.

30 CFR § 75.1106-2

Transportation of liquefied and nonliquefied compressed gas cylinders; requirements.

TRANSPORTATION, HANDLING AND STORAGE OF LIQUEFIED AND NONLIQUEFIED COMPRESSED GAS CYLINDERS

(a) Liquefied and nonliquefied compressed gas cylinders transported into or through an underground coal mine shall be:

(1) Placed securely in devices designed to hold the cylinder in place during transit on self-propelled equipment or belt conveyors;

(2) Disconnected from all hoses and gages;

(3) Equipped with a metal cap or "headband" (fence-type metal protector around the valve stem) to protect the cylinder valve during transit; and,

(4) Clearly labeled "empty" or "MT" when the gas in the cylinder has been expended.

(b) In addition to the requirements of paragraph (a) of this section, when liquefied and nonliquefied compressed gas cylinders are transported by a trolley wire haulage system into or through an underground coal mine, such cylinders shall be placed in well insulated and substantially constructed containers which are specifically designed for holding such cylinders.

(c) Liquefied and nonliquefied compressed gas cylinders shall not be transported on mantrips.

30 CFR § 75.1106-3

Storage of liquefied and nonliquefied compressed gas cylinders; requirements.

(a) Liquefied and nonliquefied compressed gas cylinders stored in an underground coal mine shall be:

(1) Clearly marked and identified as to their contents in accordance with Department of Transportation regulations.

(2) Placed securely in storage areas designated by the operator for such purpose, and where the height of the coalbed permits, in an upright position, preferably in specially designated racks, or otherwise secured against being accidentally tipped over.

(3) Protected against damage from falling material, contact with power lines and energized electrical equipment, heat from welding, cutting or soldering, and exposure to flammable liquids.

(b) Liquefied and nonliquefied compressed gas cylinders shall not be stored or left unattended in any area in by the last open crosscut of an underground coal mine.

(c) When not in use, the valves of all liquefied and nonliquefied compressed gas cylinders shall be in the closed position, and all hoses shall be removed from the cylinder.

30 CFR § 75.1107-1

Fire-resistant hydraulic fluids and fire suppression devices on underground equipment.

(a)(1) Unattended electrically powered equipment used underground which uses hydraulic fluid shall use approved fire-resistant hydraulic fluid.

(2) Except as provided in paragraph (a)(3) of this section, within 24 production shift hours after being installed, unattended electrically powered equipment used underground shall be equipped with a fire suppression device which meets the applicable requirements of [§§75.1107-3](#) through 75.1107-16.

(3) Unattended enclosed motors, controls, transformers, rectifiers, and other similar noncombustible electrically powered equipment containing no flammable fluid may be protected:

(a)(3)(i) By an approved fire suppression device, or

(a)(3)(ii) Be located at least 2 feet from coal or other combustible materials, or

(a)(3)(iii) Be separated from the coal or combustible materials by a 4-inch-thick masonry firewall or equivalent; and be mounted on a minimum 4-inch-thick noncombustible surface, platform, or equivalent. The electrical cables at such equipment shall conform with the requirements of Part [18](#) of this chapter (Bureau of Mines Schedule 2G) or be in metal conduit.

(b) Attended electrically powered equipment used underground which uses hydraulic fluid shall use approved fire-resistant hydraulic fluid unless such equipment is protected by a fire suppression device which meets the applicable requirements of [§§75.1107-3](#)--75.1107-16.

(c) For purpose of [§§75.1107](#)--75.1107-16 the following underground equipment shall be considered attended equipment:

(1) Any machine or device regularly operated by a miner assigned to operate such machine or device;

(2) Any machine or device which is mounted in the direct line of sight of a jobsite which is located within 500 feet of such machine or device and which jobsite is regularly occupied by a miner assigned to perform job duties at such jobsite during each production shift.

(d) Machines and devices described under paragraph (c) of this section must be inspected for fire and the input powerline deenergized when workmen leave the area for more than 30 minutes.

FIRES AND EXPLOSIONS

Questions for Review

Q: What is a Class C fire?

Q: What is the main gas created in White damp?

Q: What is After damp?

Q: Why are fires in underground coal mines so dangerous?

Q: What is a Class A fire?

Q: Fire damp is made up mainly of what gas?

Q: The mixture of what two gases create Black damp?

Q: What is a Class B fire?

Q: What are a few of the combustible metals?

Q: What is the minimum percentage of oxygen that must be maintained underground?
A: CFR 75.321

Q: What is a machine operator required to do when he/she finds 1% methane at the face?
A: CFR 75.323 (b)(c)

Q: What must be provided at each permanent electrical installation?
A: CFR 75.1100-2

Q: Water lines must be capable of delivering how many gallons per minute?
A: CFR 75.1100-1

Q: What fire fighting equipment must be provided at permanent oil stations?
A: CFR 75.1100-2

Q: Who establishes the requirements for the type, quality and quantity of fire fighting equipment in underground coal mines?
A: CFR 75.1100

Q: How often shall fire hydrants and fire hoses be tested?
A: CFR 75.1103

Q: What must be done during and after welding, cutting and/or soldering operations?
A: CFR 75.1106

Q: Chemical fire extinguishers must be examined how often, and where/how is the information recorded?
A: CFR 75.1100-3

Q: All underground coal mines must be rock dusted within how many feet of all working faces?
A: CFR 75.402

Q: Where rock dust is required, where shall it be applied, and in what quantities?
A: CFR 75.403

Q: Coal dust and other combustible material shall not be permitted to accumulate where?
A: CFR 75.402

Q: What must be done when 1.5% or more of methane is present in a working place or intake course?
A: CFR 75.323

Q: The methane content in bleeders and return air courses shall not exceed what percentage?
A: CFR 75.323 (e)

Q: Where shall fire suppression materials be stored underground?
A: CFR 75.1103-9 (a)

Q: What are the fire suppression materials that are required to be stored there?
A: CFR 75.1103-9

Q: What are the requirements for transporting liquefied and non-liquefied compressed gas cylinders?
A: CFR 75.1106-2

Q: What are the requirements for storage of liquefied/non-liquefied compressed gas cylinders?
A: CFR 75.1106-3

CHAPTER THREE

VENTILATION

1. Purpose and Challenges of Mine Ventilation
2. Code of Federal Regulations Part 75 - Main Mine Fans
3. Winter Alert Program
4. Math Formulas
5. Mine Map Symbols
6. Ventilating Mine Maps
7. Basic Mine Ventilation - MSHA's Illustration
8. Code of Federal Regulations Part 75 – Subpart D
9. Questions and Review

Mine Ventilation

The purpose of mine ventilation is to dilute, render harmless, and carry away dangerous accumulations of explosive and toxic gases and dust from the working environment in underground mines.

Federal safety standards for ventilating underground coal mines mandate that “the air in areas where persons work or travel shall contain at least 19.5 percent oxygen and not more than 0.5 percent carbon dioxide, and the volume and velocity of the air current in these areas shall be sufficient to dilute, render harmless, and carry away flammable, explosive, noxious, and harmful gases, dusts, smoke, and fumes.”

Hazardous concentrations of methane underground can be controlled by dilution (ventilation), capture before entering the host air stream (e.g., methane drainage), or isolation (seals and stoppings).

Explosions can be prevented or mitigated by eliminating ignition sources, by minimizing methane concentrations and coal dust accumulations, and by using passive and active barriers to suppress propagating explosions.

In coal mines, methane explosions can cause subsequent, violent explosions of coal dust. To prevent such explosions, miners cover the floor, rib and roof surfaces of mine openings with large quantities of inert rock dust such as fine limestone dust. Rock dusting is mandated by and subject to federal safety standards.

Ventilation Controls: Stoppings, Seals, Regulators and Fans

Stoppings are permanent walls constructed of brick or other approved materials. They are built to separate and isolate different air courses in underground mines, such as the fresh (intake) air from the return air or from belt airways.

Seals are substantially constructed according to federal standards. They are used to isolate worked-out areas of a mine that are no longer ventilated.

Regulators are used to adjust the quantity of air flowing to various sections of the mine.

Fans (both large, main mine fans at the surface and smaller, mobile, auxiliary fans underground) provide fresh air in mines and are usually operated by electric power.

Why is ventilation so important to coal mines?

The underground extraction of mineral resources creates one of the most hazardous work environments in the Nation. Most mining accidents today generally involve only a few individuals. However, the infrequent occurrence of gas and/or dust explosions puts the lives of the entire underground workforce at risk. More than 106 U.S. coal miners have been killed in explosions since 1980. At least five of these explosions resulted in

more than 10 fatalities each. The explosion at the McElroy Mine in West Virginia in January 2003, resulted in three deaths and three injuries. The Jim Walter Resources No. 5 Mine explosion in Alabama in September 2001 resulted in 13 deaths. In July 2000, 2 miners were killed and another 12 injured at the Willow Creek Mine explosion in Utah.

Recent explosions in underground coal mines resulted in more than 35 fatalities. Explosions can be prevented or mitigated by eliminating ignition sources, by minimizing methane concentrations and coal dust accumulations, by application of sufficient rock dust, and by using passive and active barriers to suppress propagating explosions.

NIOSH has classified diesel particulate matter (DPM) as a potential carcinogen where prolonged exposure to such contaminants can result in adverse health effects. Excessive levels of methane gas, on the other hand, can undermine the safety of the underground work force. Available methane control systems have been challenged by recent mining developments which include increased face advance rates, increased productivities, increased panel sizes, and more extensive gateroad systems. High levels of methane and other airborne contaminants in underground workings are often most easily controlled through dilution with increased ventilation airflow. Other control measures include premining drainage of methane and improved seal and stopping designs to maintain separation of intake and return air courses.

Methane is one of the most dangerous gases encountered in underground mining. In the cases of high-methane content coal, ventilation alone is sometimes not enough to sufficiently dilute these levels. In this case, coalbed degasification prior to mining and use of gob gas boreholes to drain methane from fractured strata above the mining panel are often required.

Longwall mining creates a complex underground environment that poses many problems in methane control. This includes multiple sources of gas and the necessity for an integrated use of multiple control strategies, including ventilation and methane drainage. Research under the "Control and Monitoring of Methane in Coal Mines" project determines airflow and methane emission patterns surrounding longwall faces and gobs to improve methane control systems. The complicated interaction of the main, tailgate, and bleeder ventilation systems is investigated to improve our understanding of methane flow paths. This modeling effort predicts the expected increases in gas emissions when extracting substantially larger longwall panels, a trend that the industry is currently following.

Information for ventilation was obtained from the following publications/websites:

- **NIOSH Office of Mine Safety and Health Research**
- **Mine Safety & Health Administration (MSHA)**



Title 30

Code of Federal Regulation

Part 75 - Main Mine Fans

30 CFR § 75.310

Installation of main mine fans.

(a) Each main mine fan shall be--

(1) Installed on the surface in an incombustible housing;

(2) Connected to the mine opening with incombustible air ducts;

(3) Equipped with an automatic device that gives a signal at the mine when the fan either slows or stops. A responsible person designated by the operator shall always be at a surface location at the mine where the signal can be seen or heard while anyone is underground. This person shall be provided with two-way communication with the working sections and work stations where persons are routinely assigned to work for the majority of a shift;

(4) Equipped with a pressure recording device or system. Mines permitted to shut down main mine fans under [§75.311](#) and which do not have a pressure recording device installed on main mine fans shall have until June 10, 1997 to install a pressure recording device or system on all main mine fans. If a device or system other than a circular pressure recorder is used to monitor main mine fan pressure, the monitoring device or system shall provide a continuous graph or continuous chart of the pressure as a function of time. At not more than 7-day intervals, a hard copy of the continuous graph or chart shall be generated or the record of the fan pressure shall be stored electronically. When records of fan pressure are stored electronically, the system used to store these records shall be secure and not susceptible to alteration and shall be capable of storing the required data. Records of the fan pressure shall be retained at a surface location at the mine for at least 1 year and be made available for inspection by authorized representatives of the Secretary and the representative of miners;

(5) Protected by one or more weak walls or explosion doors, or a combination of weak walls and explosion doors, located in direct line with possible explosive forces;

(6) Except as provided under paragraph (e) of this section, offset by at least 15 feet from the nearest side of the mine opening unless an alternative method of protecting the fan and its associated components is approved in the ventilation plan.

(1) If an electric motor is used to drive a main mine fan, the motor shall operate from a power circuit independent of all mine power circuits.

(2) If an internal combustion engine is used to drive a main mine fan--

(i) The fuel supply shall be protected against fires and explosions;

(ii) The engine shall be installed in an incombustible housing and be equipped with a remote shut-down device;

(iii) The engine and the engine exhaust system shall be located out of direct line of the air current exhausting from the mine; and

(iv) The engine exhaust shall be vented to the atmosphere so that the exhaust gases do not contaminate the mine intake air current or any enclosure.

(c) If a main mine fan monitoring system is used under [§75.312](#), the system shall--

(1) Record, as described in paragraph (a)(4) the mine ventilating pressure;

(2) Monitor bearing temperature, revolutions per minute, vibration, electric voltage, and amperage;

(3) Provide a printout of the monitored parameters, including the mine ventilating pressure within a reasonable period, not to exceed the end of the next scheduled shift during which miners are underground; and

(4) Be equipped with an automatic device that signals when--

(i) An electrical or mechanical deficiency exists in the monitoring system; or

(ii) A sudden increase or loss in mine ventilating pressure occurs.

(5) Provide monitoring, records, printouts, and signals required by paragraphs (c)(1) through (c)(4) at a surface location at the mine where a responsible person designated by the operator is always on duty and where signals from the monitoring system can be seen or heard while anyone is underground. This person shall be provided with two-way communication with the working sections and work stations where persons are routinely assigned to work for the majority of a shift.

(d) Weak walls and explosion doors shall have cross-sectional areas at least equal to that of the entry through which the pressure from an explosion underground would be relieved. A weak wall and explosion door combination shall have a total cross-sectional area at least equal to that of the entry through which the pressure from an explosion underground would be relieved.

(e) If a mine fan is installed in line with an entry, a slope, or a shaft--

(1) The cross-sectional area of the pressure relief entry shall be at least equal to that of the fan entry;

(2) The fan entry shall be developed out of direct line with possible explosive forces;

(3) The coal or other solid material between the pressure relief entry and the fan entry shall be at least 2,500 square feet; and

(4) The surface opening of the pressure relief entry shall be not less than 15 feet nor more than 100 feet from the surface opening of the fan entry and from the underground intersection of the fan entry and pressure relief entry.

(f) In mines ventilated by multiple main mine fans, incombustible doors shall be installed so that if any main mine fan stops and air reversals through the fan are possible, the doors on the affected fan automatically close.

30 CFR § 75.311

Main mine fan operation.

(a) Main mine fans shall be continuously operated, except as otherwise approved in the ventilation plan, or when intentionally stopped for testing of automatic closing doors and automatic fan signal devices, maintenance or adjustment of the fan, or to perform maintenance or repair work underground that cannot otherwise be made while the fan is operating.

(b) Except as provided in paragraph (c) of this section, when a main mine fan is intentionally stopped and the ventilating quantity provided by the fan is not maintained by a back-up fan system--

(1) Only persons necessary to evaluate the effect of the fan stoppage or restart, or to perform maintenance or repair work that cannot otherwise be made while the fan is operating, shall be permitted underground;

(2) Mechanized equipment shall be shut off before stopping the fan; and

(3) Electric power circuits entering underground areas of the mine shall be deenergized.

(c) When a back-up fan system is used that does not provide the ventilating quantity provided by the main mine fan, persons may be permitted in the mine and electric power circuits may be energized as specified in the approved ventilation plan.

(d) If an unusual variance in the mine ventilation pressure is observed, or if an electrical or mechanical deficiency of a main mine fan is detected, the mine foreman or equivalent mine official, or in the absence of the mine foreman or equivalent mine official, a designated certified person acting for the mine foreman or equivalent mine official shall be notified immediately, and appropriate action or repairs shall be instituted promptly.

(e) While persons are underground, a responsible person designated by the operator shall always be at a surface location where each main mine fan signal can be seen or heard.

(f) The area within 100 feet of main mine fans and intake air openings shall be kept free of combustible material, unless alternative precautions necessary to provide protection from fire or other products of combustion are approved in the ventilation plan.

(g) If multiple mine fans are used, the mine ventilation system shall be designed and maintained to eliminate areas without air movement.

(h) Any atmospheric monitoring system operated during fan stoppages shall be intrinsically safe.

30 CFR § 75.312

Main mine fan examinations and records.

(a) To assure electrical and mechanical reliability of main mine fans, each main mine fan and its associated components, including devices for measuring or recording mine ventilation pressure, shall be examined for proper operation by a trained person designated by the operator. Examinations of main mine fans shall be made at least once each day that the fan operates, unless a fan monitoring system is used. No examination is required on any day when no one, including certified persons, goes underground, except that an examination shall be completed prior to anyone entering the mine.

(b) If a main mine fan monitoring system is used, a trained person designated by the operator shall--

(i) At least once each day review the data provided by the fan monitoring system to assure that the fan and the fan monitoring system are operating properly. No review is required on any day when no one, including certified persons, goes underground, except that a review of the data shall be performed prior to anyone entering the underground portion of the mine. Data reviewed should include the fan pressure, bearing temperature, revolutions per minute, vibration, electric voltage, and amperage; and

(ii) At least every 7 days--

(A) Test the monitoring system for proper operation; and

(B) Examine each main mine fan and its associated components to assure electrical and mechanical reliability of main mine fans.

(2) If the monitoring system malfunctions, the malfunction shall be corrected, or paragraph (a) of this section shall apply.

(c) At least every 31 days, the automatic fan signal device for each main mine fan shall be tested by stopping the fan. Only persons necessary to evaluate the effect of the fan stoppage or restart, or to perform maintenance or repair work that cannot otherwise be made while the fan is operating, shall be permitted underground. Notwithstanding the requirement of [§75.311\(b\)\(3\)](#), underground power may remain energized during this test provided no one, including persons identified in [§75.311\(b\)\(1\)](#), is underground. If the fan is not restarted within 15 minutes, underground power shall be deenergized and no one shall enter any underground area of the mine until the fan is restarted and an examination of the mine is conducted as described in [§75.360\(b\)](#) through (e) and the mine has been determined to be safe.

(d) At least every 31 days, the automatic closing doors in multiple main mine fan systems shall be tested by stopping the fan. Only persons necessary to evaluate the effect of the fan stoppage or restart, or to perform maintenance or repair work that cannot otherwise be made while the fan is operating, shall be permitted underground. Notwithstanding the provisions of [§75.311](#), underground power may remain energized during this test provided no one, including persons identified in [§75.311\(b\)\(1\)](#), is underground. If the fan is not restarted within 15 minutes, underground power shall be deenergized and no one shall enter any underground area of the mine, until the fan is restarted and an examination of the mine is conducted as described in [§75.360\(b\)](#) through (e) and the mine has been determined to be safe.

(e) Circular main mine fan pressure recording charts shall be changed before the beginning of a second revolution.

(f) *Certification.* Persons making main mine fan examinations shall certify by initials and date at the fan or another location specified by the operator that the examinations were made. Each certification shall identify the main mine fan examined.

(2) Persons reviewing data produced by a main mine fan monitoring system shall certify by initials and date on a printed copy of the data from the system that the review was completed. In lieu of certification on a copy of the data, the person reviewing the data may certify electronically that the review was completed. Electronic certification shall be by handwritten initials and date in a

computer system so as to be secure and not susceptible to alteration.

(g) *Recordkeeping.* By the end of the shift on which the examination is made, persons making main mine fan examinations shall record all uncorrected defects that may affect the operation of the fan that are not corrected by the end of that shift. Records shall be maintained in a secure book that is not susceptible to alteration or electronically in a computer system so as to be secure and not susceptible to alteration.

(2) When a fan monitoring system is used in lieu of the daily fan examination--

(i) The certified copies of data produced by fan monitoring systems shall be maintained separate from other computer-generated reports or data; and

(ii) A record shall be made of any fan monitoring system malfunctions, electrical or mechanical deficiencies in the monitoring system and any sudden increase or loss in mine ventilating pressure. The record shall be made by the end of the shift on which the review of the data is completed and shall be maintained in a secure book that is not susceptible to alteration or electronically in a computer system so as to be secure and not susceptible to alteration.

(3) By the end of the shift on which the monthly test of the automatic fan signal device or the automatic closing doors is completed, persons making these tests shall record the results of the tests. Records shall be maintained in a secure book that is not susceptible to alteration or electronically in a computer system so as to be secure and not susceptible to alteration.

(h) *Retention period.* Records, including records of mine fan pressure and the certified copies of data produced by fan monitoring systems, shall be retained at a surface location at the mine for at least 1 year and shall be made available for inspection by authorized representatives of the Secretary and the representative of miners.

30 CFR § 75.313

Main mine fan stoppage with persons underground.

(a) If a main mine fan stops while anyone is underground and the ventilating quantity provided by the fan is not maintained by a back-up fan system--

(1) Electrically powered equipment in each working section shall be deenergized;

(2) Other mechanized equipment in each working section shall be shut off; and

(3) Everyone shall be withdrawn from the working sections and areas where mechanized mining equipment is being installed or removed.

(b) If ventilation is restored within 15 minutes after a main mine fan stops, certified persons shall examine for methane in the working places and in other areas where methane is likely to accumulate before work is resumed and before equipment is energized or restarted in these areas.

(c) If ventilation is not restored within 15 minutes after a main mine fan stops--

(c) Everyone shall be withdrawn from the mine;

(2) Underground electric power circuits shall be deenergized. However, circuits necessary to withdraw persons from the mine need not be deenergized if located in areas or haulageways where methane is not likely to migrate to or accumulate. These circuits shall be deenergized as persons are withdrawn; and

(3) Mechanized equipment not located on working sections shall be shut off. However, mechanized equipment necessary to withdraw persons from the mine need not be shut off if located in areas where methane is not likely to migrate to or accumulate.

(d) When ventilation is restored--

(i) No one other than designated certified examiners shall enter any underground area of the mine until an examination is conducted as described in [§75.360\(b\)](#) through (e) and the area has been determined to be safe. Designated certified examiners shall enter the underground area of the mine from which miners have been withdrawn only after the fan has operated for at least 15 minutes unless a longer period of time is specified in the approved ventilation plan.

(ii) Underground power circuits shall not be energized and nonpermissible mechanized equipment shall not be started or operated in an area until an examination is conducted as described in [§75.360\(b\)](#) through (e) and the area has been determined to be safe, except that designated certified examiners may use nonpermissible transportation equipment in intake airways to facilitate the making of the required examination. (2) If ventilation is restored to the mine before miners reach the surface, the miners may return to underground working areas only after an examination of the areas is made by a certified person and the areas are determined to be safe. (e) Any atmospheric monitoring system operated during fan stoppages shall be intrinsically safe.

(f) Any electrical refuge alternative components exposed to the mine atmosphere shall be approved as intrinsically safe for use during fan stoppages. Any electrical refuge alternative components located inside the refuge alternative shall be either approved as intrinsically safe or approved as permissible for use during fan stoppages.



Winter Alert

“Beat Winter Hazard, Win with Winter Alert”

"Conditions at underground and surface coal mines can change dramatically during the winter months," said Joseph A. Main, assistant secretary of labor for mine safety and health. "We must be ever mindful of the seasonal changes that can affect our work environments."

Low barometric pressures and low humidity, coupled with seasonal drying of many areas in underground coal mines, have contributed to the larger number of mine explosions during winter months. Other hazards include limited visibility, icy haulage roads and walkways, and the freezing and thawing effect on highwalls at surface mines.

MSHA warns miners and operators at underground coal mines to follow safety checklists by ensuring adequate ventilation, applying liberal amounts of rock dust, conducting frequent and thorough examinations, and being familiar with emergency procedures to prevent coal mine ignitions and explosions.

Miners also are urged to be vigilant about keeping escapeways clear of impediments. Miners and operators of surface mines should examine the stability of highwalls, remove snow and ice from walkways, de-ice any equipment, and apply salt and sand liberally where needed.

During their normal inspection duties, MSHA inspectors will distribute posters, hardhat stickers, a "practice ventilation awareness" pocket card and a "basic ventilation" compact disc PowerPoint presentation that can be shown and discussed during meetings with underground coal miners.

Coal Miner's Ventilation Checklist

Always.. conduct methane checks:

- *before..* equipment is energized at the face
- *at least..* every 20 minutes (or more often if required by the mine's ventilation plan)
- *before..* equipment is trammed in by the last open crosscut immediately
- *before..* welding, cutting, or soldering
- *continuously..* during welding, cutting, or soldering immediately before and
- *after..* blasting
- **Always..** make sure ALL gas detectors are calibrated and operating properly.
- **Always..** keep line brattice or ventilation tubing within 10 feet of the face (or other distance required in your mine's ventilation plan).
- **Always..** report:
 - ventilation control leakage..
 - changes in air velocity..
 - methane gas feeders..
 - ventilation tubing leaks..
 - smoke and other strange odors ..
- **Always..** report and/or repair damage to ventilation controls (i.e. stoppings, line brattice, check curtains, regulators).
- **Always..** report and/or repair damage to ventilation controls (i.e. stoppings, line brattice, check curtains, regulators).
- **Always..** make sure water sprays and scrubber systems are properly operated and maintained in accordance with manufacturers' recommendations and your mine's ventilation plan.
- **Never..** change or alter any ventilation controls without proper authorization.
- **Never..** operate an auxiliary fan if the main fan is down.
- **Never..** use an auxiliary fan to remove methane – use line brattice.

Basic math formulas used to figure ventilation equations.

Symbols Key:

π = pi (3.1416)	d = diameter
o = circumference or perimeter	r = radius
p = ventilating pressure	l = length
v = air velocity (fpm)	w = width
A = Area	h = height
Q = Air Quantity (cfm)	fpm = feet per minute
lo = rubbing surface	cfm = cubic feet per minute
k = coefficient of friction (0.00000001)	

Circumference or Perimeter = width + width + length + length
 $o = w + w + l + l$

Area = width x length (or height)
 $A = w \times l$ (or $w \times h$)

Area of a circle = $A = \pi \times r^2$ Radius = $d / 2$

Rubbing Surface = perimeter x length
 $S = o \times l$

Velocity x Area = Air Quantity (cfm)
 $V \times A = Q$

Air Quantity \div Velocity = Area
 $Q \div V = A$

Air Quantity \div Area = Velocity
 $Q \div A = V$

Liberation of methane = cfm x CH₄%

Dilution of methane =
 cfm x CH₄% \div CH₄% desired (i.e. 1%)

Changing seconds to feet per minute (fpm):
 $60 \div \text{seconds} = \text{parts of a minute (pM)}$
 pM x feet = fpm

Changing feet per minute (fpm) to feet per hour:
 fpm x 60 = feet per hour

Changing feet per hour to feet per day:
 feet per hour x 24 = feet per day

Changing inches to feet:
 Inches \div 12 = feet

Formula to figure water gauge inches

$$p = (k) \times (lo) \times (v^2) \div A$$

PREPARING THE MAP --- MAP SYMBOLS

The first step in reading any type of map is an understanding of the symbols used to depict its features. When reading a road map many of the symbols are familiar and do not require any additional interpretation on the part of the user. This knowledge has been gained through experience aided by the availability of road maps for public use. Mine maps are no different. Once an understanding of the symbols is attained, the map can be read and understood. Although many mine map symbols are standardized, some are not. It is important that a legend be placed on the map to illustrate the meaning of each symbol. The reader must consult the legend to understand the map.

SCALE

The mine map must have a scale to indicate the distances. The scale tells the reader the distance that one inch on the map represents. The scale may look like this:

SCALE 1" = 100'

or this:

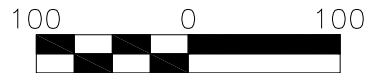

Both above scales indicate that one inch on the mine map represents 100 feet in the mine, and the lower scale indicates that one small block represents 25 feet.

BOREHOLES

A borehole is a hole connecting the surface with the underground workings of a mine. the hole may be as small as 2 inches in diameter for a diamond drill hole or as large as 30 feet for an airshaft.

⊙ WATER BOREHOLE

⊙ POWER BOREHOLE

● DDH DIAMOND DRILL HOLE

◐ CIRCULAR AIR SHAFT

◑ RECTANGULAR AIR SHAFT

◒ RECTANGULAR AIR SHAFT
(ONE COMPARTMENT)

☀ OIL OR GAS WELL

ELEVATION

Mine floors are not level. There are high and low places in a mine. The elevations represent the distances in feet from sea level to the mine floor. On the mine map elevations look like this:

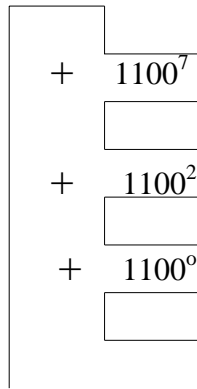

VENTILATION CONTROL SYMBOLS

Fan - A mechanical device powered by an electrically driven motor or by an internal combustion engine to pull or push air through the mine workings.

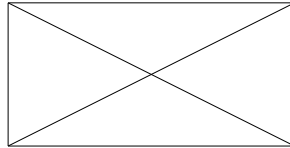

Check Curtain - A partition made of incombustible material, such as plastic or canvas, used to deflect or direct air to the working place. It is constructed in a manner to allow the passage of men and machinery.

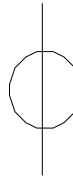

Box Check - A stopping with an opening in it to allow a conveyor to pass through used to prevent intake or return air from flowing across the conveyor.

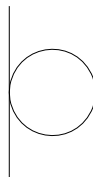

Door - A large hinged door completely closing a mine entry. Doors are usually installed in pairs to form an air lock, allowing haulage equipment to pass through one door at a time without allowing air to flow.

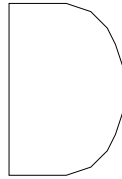

Line brattice - A partition made of incombustible material used to direct air to the working face, which is usually installed within ten (10) feet of the face.



Overcast - An enclosure built in an intersection of mine passages which allows two air currents to cross without mixing. One air current crosses the other above the coal seam, or in some instances through pipes.

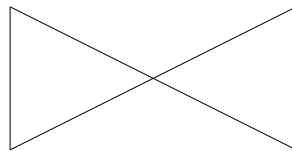

Undercast - Similar to an overcast except that one air current crosses under the other below the coal seam.

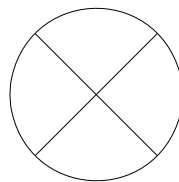

Regulator - An adjustable door or opening in a stopping generally placed across a return airway, and used to adjust the amount of air passing through the airway in order to properly distribute airflow.

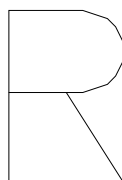

Stopping (permanent) - A solid incombustible substantial wall built across a mine passage to separate intake air from return air, to direct air through the mine, to form escapeways, and to isolate belt conveyer entries.



Stopping (temporary) - A stopping built of less substantial material than permanent ones which is used in places where the ventilation will be changed and generally replaced by permanent stoppings.



Seal - A stopping built of greater thickness and more substantial construction used to isolate abandoned areas of a mine from the active workings.



Mandoor - A door installed in a permanent stopping to allow persons to travel from one entry to another which must be constructed to prevent air from leaking through the stopping when the door is closed.

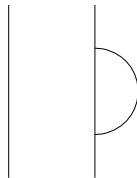

INSTRUCTIONS FOR VENTILATING MAPS

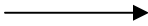
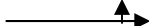
1. Neatness is the first rule for ventilating maps. Arrows and ventilating controls should be as neat and workmanlike as it is practical to make them.
2. All ventilating controls and arrows showing direction of air flow are to be drawn with a black lead pencil.
3. All arrows are to be drawn with a ruler as guide. 
4. Air currents should be so well outlined that it will be easy to trace them at a glance.
5. Show all places where the air splits by this symbol. 
6. Study the map and get a general idea of how the air should be coursed, taking haulage into consideration as well as the probable types of equipment used.
7. Whenever possible, separate main intake and return air with long chain pillars.
8. After deciding on the flow of air, ventilate the main entries. This establishes the main intakes and returns.
9. Now set the fan, offsetting it 15' from the opening and indicating the explosion doors. Beside the fan write the following mine law pertaining to the fan.
 - 1) Offset at least 15' feet.
 - 2) Fireproof air ducts provided with explosion doors or weak wall.
 - 3) Operated from independent power circuit
 - 4) Provided with pressure recording gauges or water gauges.
 - 5) Daily inspection of fan and a record of inspection kept in a book or by facilities to permanently record or give warning of an interruption to the fan.
10. Next, ventilate one butt entry taking into consideration the haulage and the manner in which the air will be coursed into and out of each individual section.
11. Ventilate one section at a time on the butt entry and place each section on a separate split of air. In general, ventilate the least developed section first.
12. When ventilating the sections first indicate by arrows where you want the air to go. Then place the necessary controls to make it go that way. For example: Show the flow of air by arrows. Then place the permanent stoppings and doors. Next place temporary stoppings and checks. Then if you are air locking a section, check to see if you do have an airlock. Now put line brattice or ventilating tubing in all places that are in more than 2 cuts or 20 feet. Last, regulate all splits of air. For example, you may have air going out the main return to regulate and a bleeder for a pillar line to regulate.
13. When ventilating a section that has both solid and pillared workings, course the air over the solid workings first. Air used for ventilating abandoned or pillared workings should be coursed directly to the return.
14. Air locks are placed where there is danger of interruption to face ventilation. In general, sections such as those that use track mounted face equipment or pan lines to the faces or hand loading into cars or conveyors should be air locked.
15. Where possible, sections that use shuttle cars should be ventilated by taking the air up the middle headings and splitting the air at the face (fish-tailing). This will reduce the problem of removing gas and sealing in the event of a mine fire.
16. Every split of air should be regulated. Regulators should be placed so that one regulator does not regulate another (double regulation).
17. Mark all violations of the mine law.
18. Check maps carefully. Be sure that all controls are in and properly placed. Check the air flow to be certain there are no short circuits and that one regulator is not regulating another.

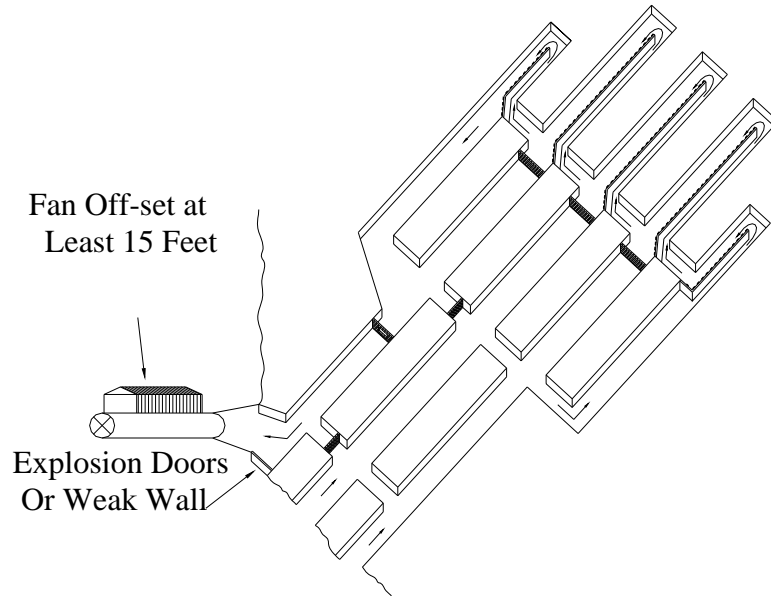

Air circulates through a mine because there is a difference in pressure between the intake and the return. The difference in pressure can be created by the difference in temperature, elevation, or by mechanical means. See illustrations. Natural ventilation isn't reliable because the direction, of the air current, may reverse with weather conditions, and when the outside temperature approximates the inside temperature, movement of air will cease.

The most reliable method of producing ventilation (coursing of air through a mine) is by a fan operated mechanically. A mine fan must be located on the surface, and must be built with incombustible material, equipped with fire proof air ducts and provided with explosion doors or a weak wall.

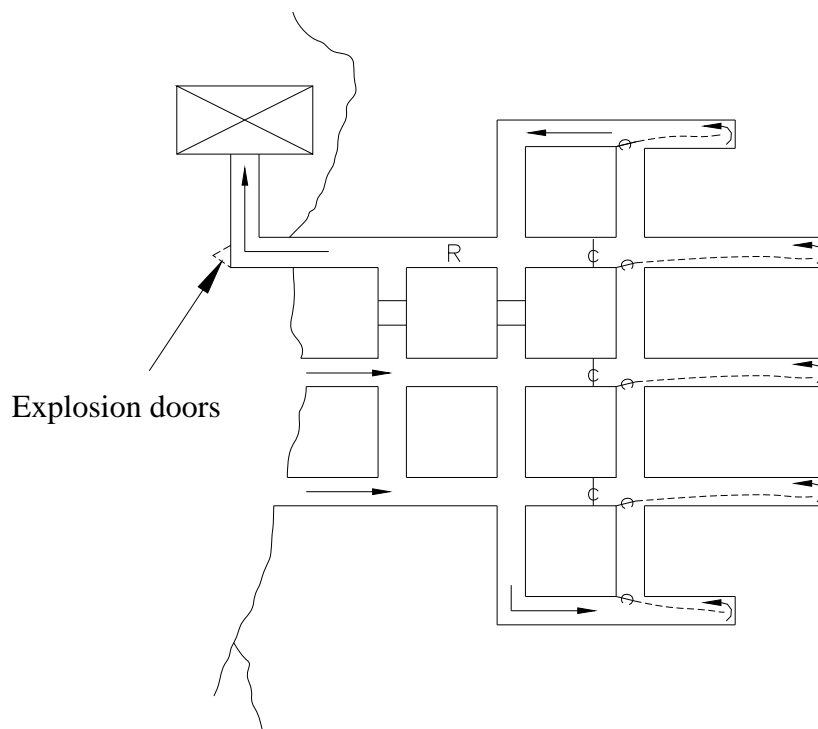

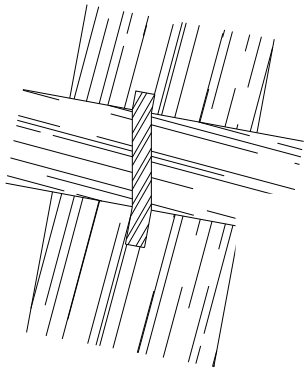

Figure 1

Figure 3

PERMANENT STOPPING

The purpose of a stopping is to prevent the short circuiting of the air or to seal off portions of the mine. Short circuiting of air is permitting it to enter the return before it has reached the working faces.

A leaky stopping will increase the cost of ventilation. The fan will be required to move a greater quantity of air than necessary to properly ventilate the working areas. Therefore, a stopping should be airtight and substantial. One common area of leakage in the construction of a stopping is around the sides and on the bottom. When possible a stopping should be embedded into the rib and bottom. See illustration #1.

OVERCAST

An overcast is a bridge which allows one air current to pass over another air current. Usually overcasts are built in an intersection opposite a break-through. See Figure #1 and #2. An air bridge is an aid to ventilation because it permits frequent splitting of the air - allowing air to pass only over one section or one portion of a mine. An overcast also aids the haulage of a mine because it eliminates the necessity for doors on the haulage road. The most common errors made in the construction of an overcast are: rough and abrupt interruption to the ventilating current, and insufficient area. The area on the inside of the overcast which butts up against the construction should be filled in with material and smoothed down so that air will flow easily over the top of the overcast. The distance from the top of the overcast to the roof should be of sufficient area to allow air to pass freely. See Figure #3.

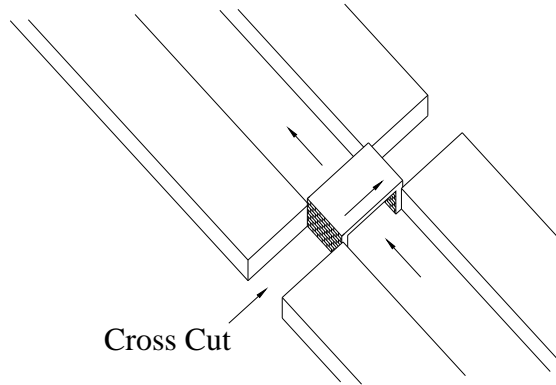

Figure #1

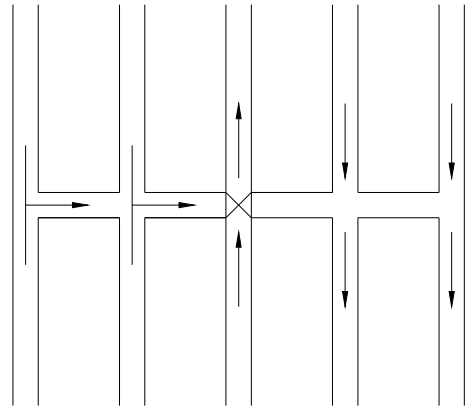
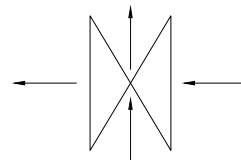
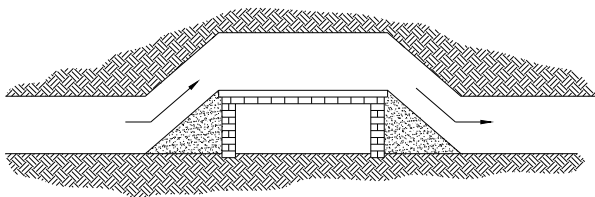

Figure #2

Figure #3



CHECK CURTAIN AND LINE BRATTICE

The purpose of a check curtain is to deflect an air current from an entry into a working face and should only be used in the active working area. The use of a line brattice with a check curtain is a standard practice in coal mining. See examples. The material used is brattice cloth or incombustible material and must be flame resistant. The purpose of a line brattice is to assure a sufficient velocity of air at the working face to remove dangerous gases, smoke from explosives, and to carry away harmful coal dust. The most common error in the use of line curtain is the choking of the air in behind the curtain. Therefore, the space behind a line curtain should be clear and open for the free flow of air. At times a greater velocity of air may be needed at the face area to remove gas.

In such cases the intake current can be constricted, thereby creating a greater velocity and the gas is removed.

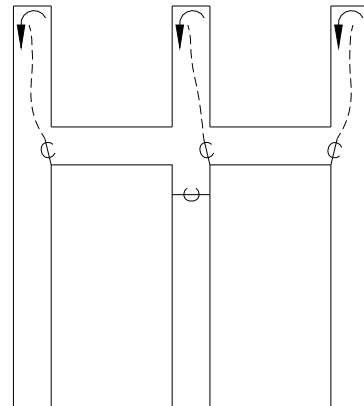
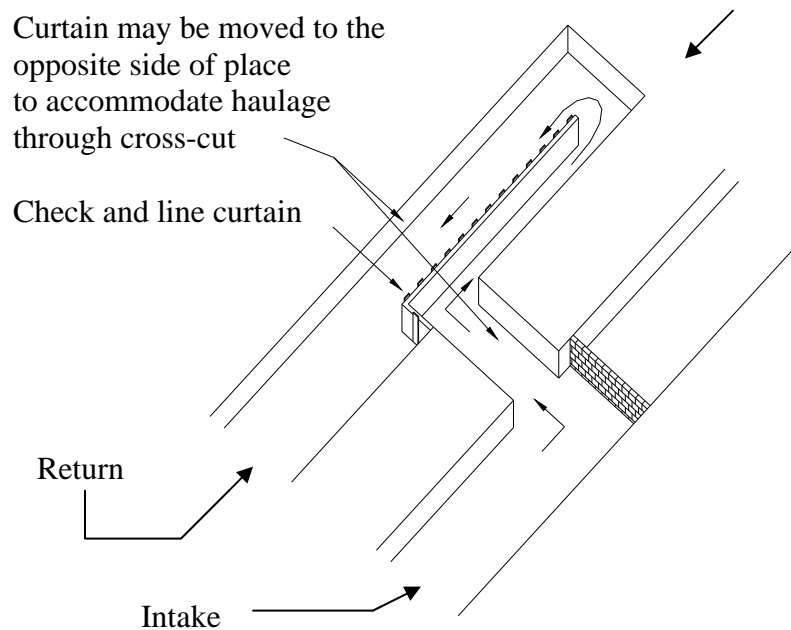

REGULATOR

The purpose of a regulator is to control the distribution of air by regulating the resistance to flow in an air split. Therefore, the effect of closing a regulator on the quantity of air is that the quantity will decrease. Regulators are essential to the ventilation of a mine because they proportion the air to meet the requirements of each individual split. Regulators are placed in the return of each split of air. The mine foreman—who is charged with the responsibility of ventilating coal mines in Utah—will determine where regulators are to be placed. The materials used in the construction of a regulator should be incombustible.

R

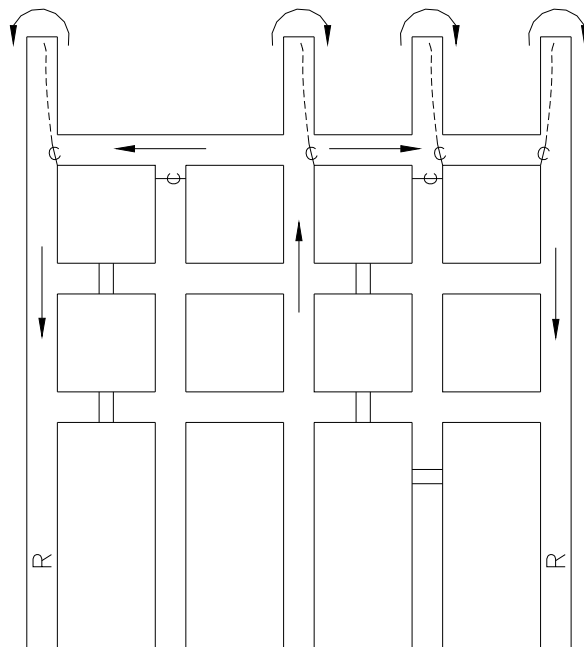
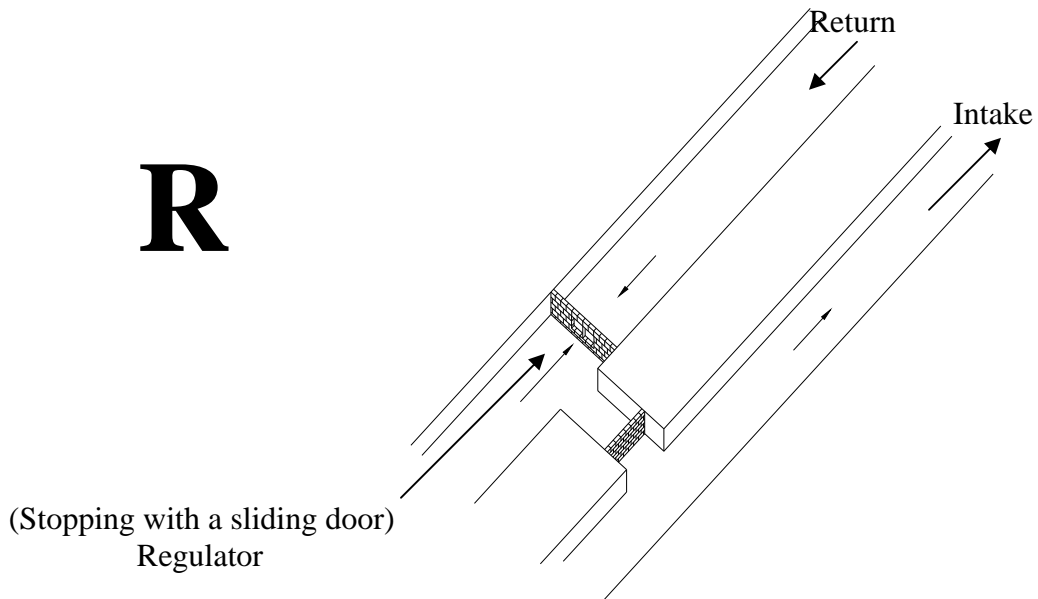

BOX---CHECK

Where belts or panlines pass through a stopping they should be boxed checked to prevent excess leakage of air. Notice in the example below a belt line is passing through two permanent stoppings. The belt is ventilated by the leakage of air through the stoppings.

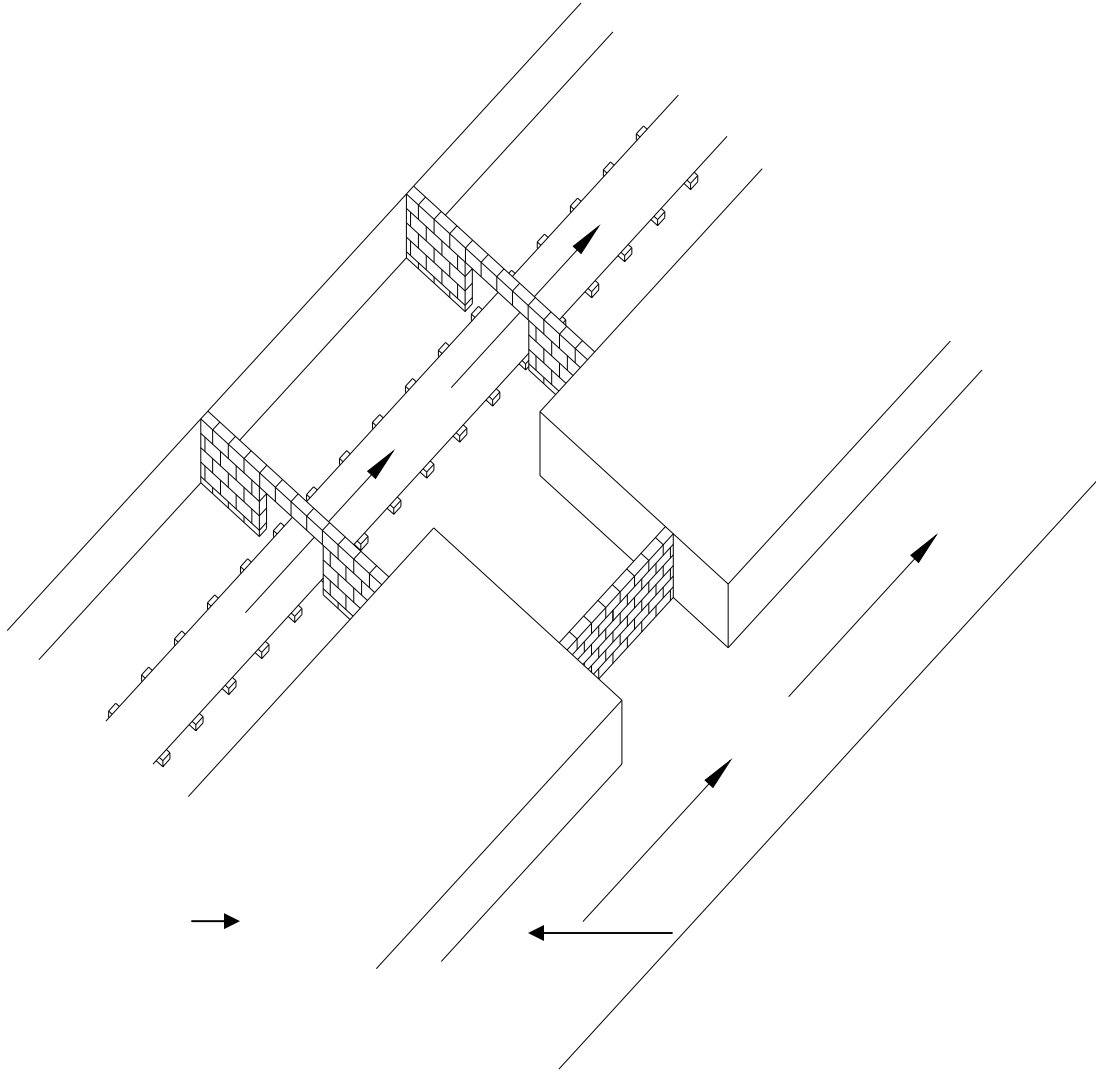

1. Pull power
2. Remove men except those necessary to remove gas and seal fire.
3. To get more air to remove gas; tighten check and line curtain open regulator No. 2.
4. Approximately 1000 feet from fire area build temporary seals.
5. Build permanent seals. Build seals No. 2 and No. 4 first, then build seals No. 1, No. 3, and No. 5 simultaneously. Seals No.1, No. 3, and No.5 must be raised together to prevent the possibility of reversing the air in the fire area.. If necessary put in water traps. Make as airtight as possible.
6. Establish ventilation across seals by removing stoppings 6, build stopping 7, and run line curtain to face 8. Adjust regulators No. 1 and No. 2.

- (1) Sample Tubes
- (2) Temporary Seals
- (3) Permanent Seals
- (4) Temporary Stoppings
- (5) Permanent Stoppings
- (6) Remove Stoppings
- (7) Build Stoppings
- (8) Run Line Curtain to Stoppings
- (9) Adjust Regulators

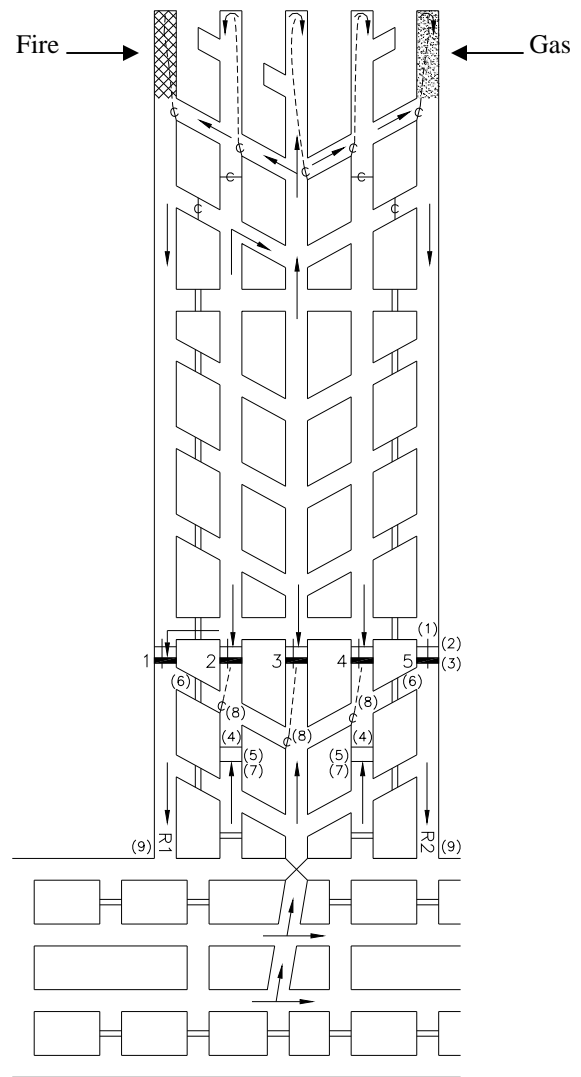

Instructions for Removing Gas and Sealing Mine Fire

1. Pull power
2. Remove men except those necessary to remove the gas and seal the fire.
3. Route the gas away from the fire area so the gas does not cross the fire and cause an explosion.
4. Increase the volume of air to remove the gas
5. Approximately 1,000 feet from the fire area build temporary seals approximately straight across.
6. Outby the temporary seals build permanent seals. When building seals the last seals to be built are one in each return and one in the intake. These are raised together so as to prevent the possibility of reversing the air in the fire area. Sample tubes are put in two or more seals. This sampling is done about 72 hours after the initial sealing for the purpose of determining whether the oxygen content is low enough so there is no danger of an explosion. If necessary put water traps in the seals.
7. Ventilate the seals.

MSHA'S

Basic Mine Ventilation

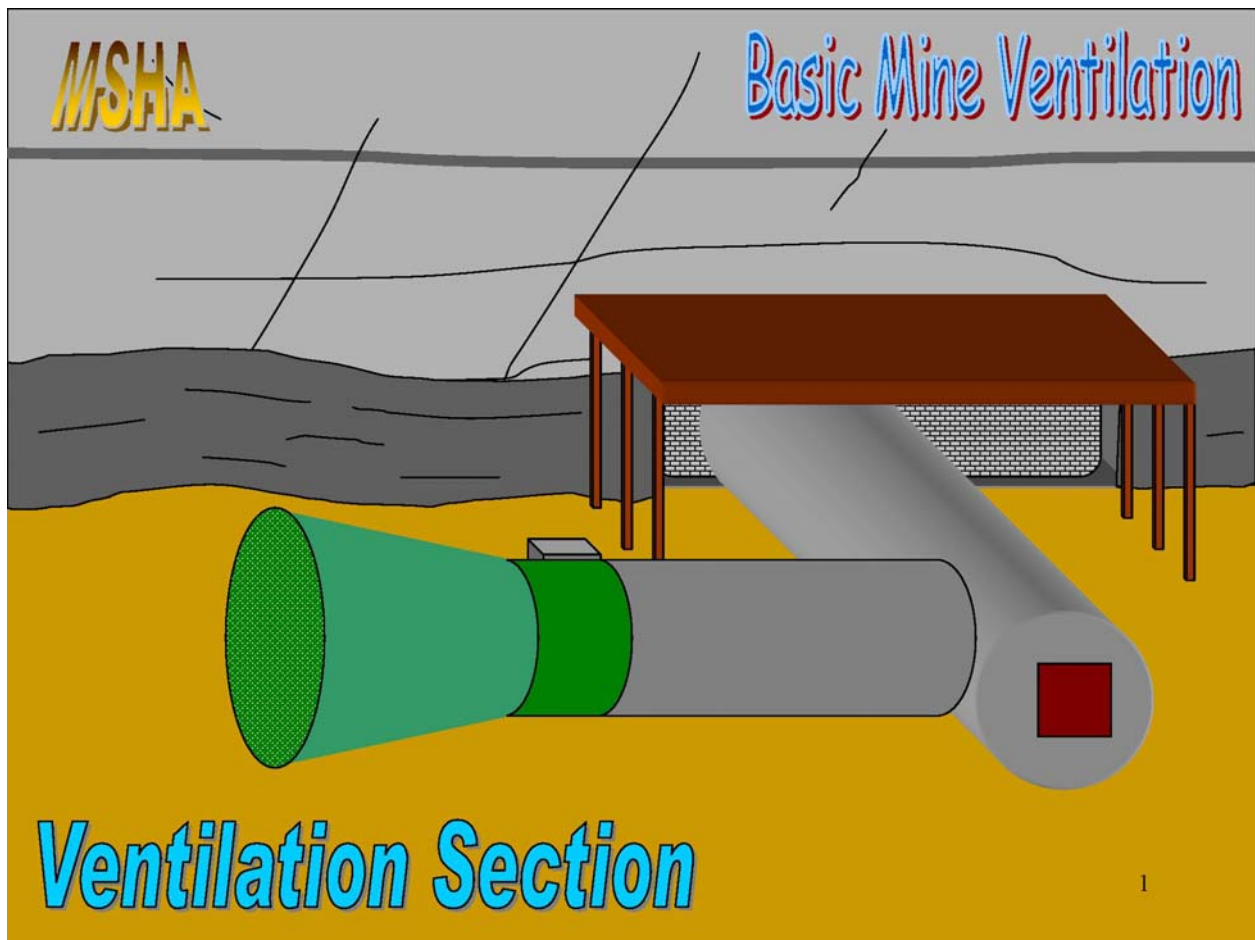

Introduction

- Face Ventilation
 - Stoppings
 - Check Curtains
 - Air Measurements
- Principals of Airflow
- Respirable Dust Control
- Use of Scrubbers
- Actions for Excessive Methane
- Rock Dusting
- Permissibility

The principal mechanism for taking medium air velocity measurement is the Anemometer.

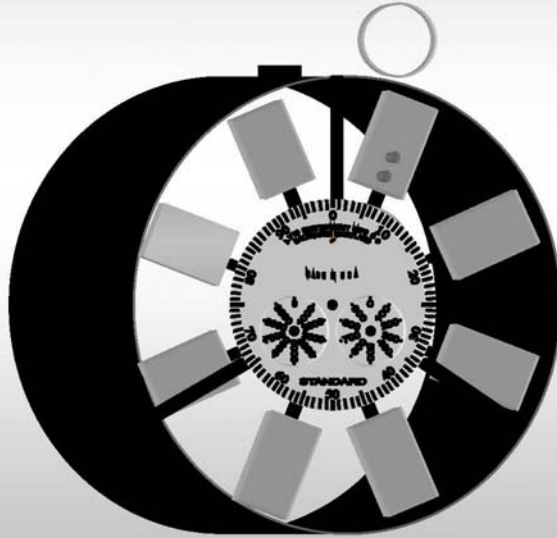

A high speed anemometer is most often used for high velocity air measurements!

3

Air always flows from a point of higher to lower pressure.

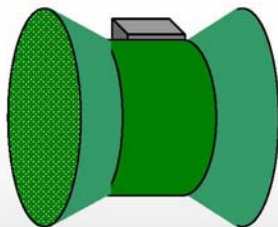

- * Blowing fans create a high pressure point immediately in by the fan. Air travels from this high point through the mine to the surface.
- * Exhausting fans create a low pressure point immediately in by the fan. Air travels from the surface through the mine to this low pressure point.

8

Principals of Airflow

4

Airflow in a mine is induced by pressure differences between intake and exhaust openings.

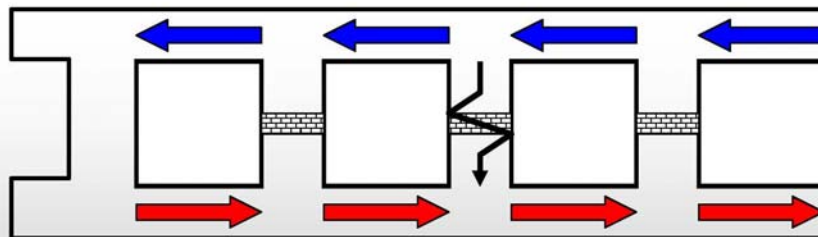

5

The pressure difference is caused by imposing some form of pressure at one point or a series of points in the ventilating system.

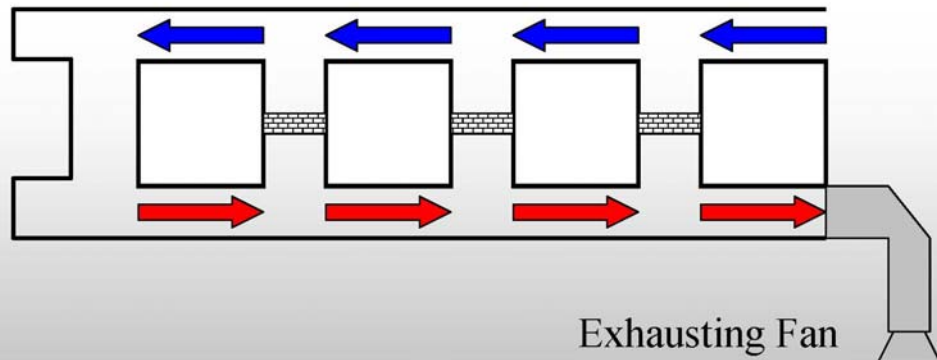

6

Passageways, both intake and returns must be provided to conduct airflow

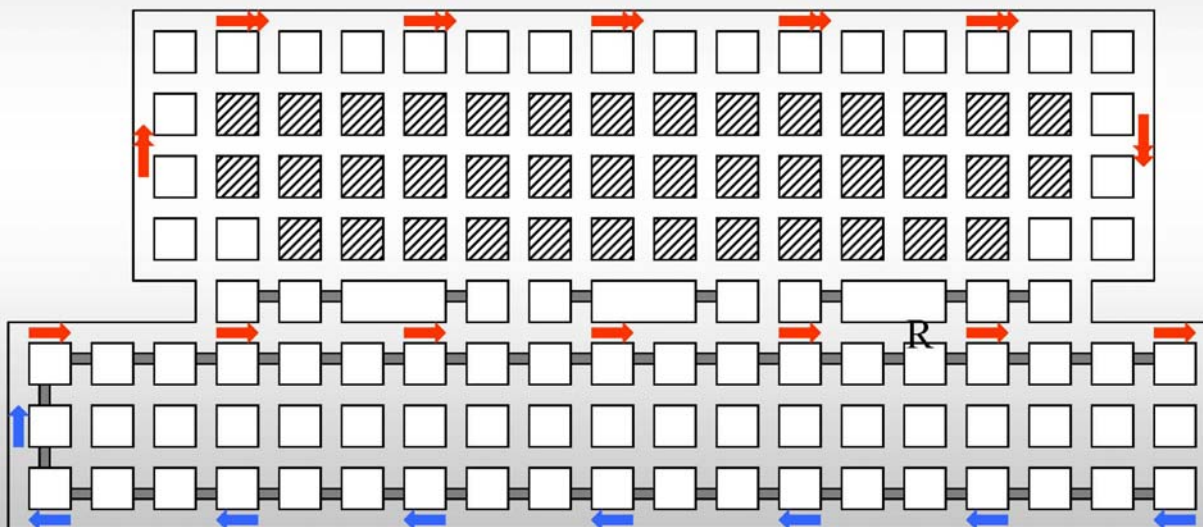

7

Permissible Electric Equipment

- In order to prevent methane ignitions caused by electrical equipment, all such equipment taken into or used in by the last open crosscut, in return air or located within 150 feet of pillar workings or longwall faces must be maintained in permissible condition

54

Air always flows from a point of higher to lower pressure.

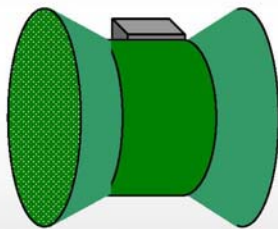

- * Blowing fans create a high pressure point immediately in by the fan. Air travels from this high point through the mine to the surface.
- * Exhausting fans create a low pressure point immediately in by the fan. Air travels from the surface through the mine to this low pressure point.

8

Blowing Fan

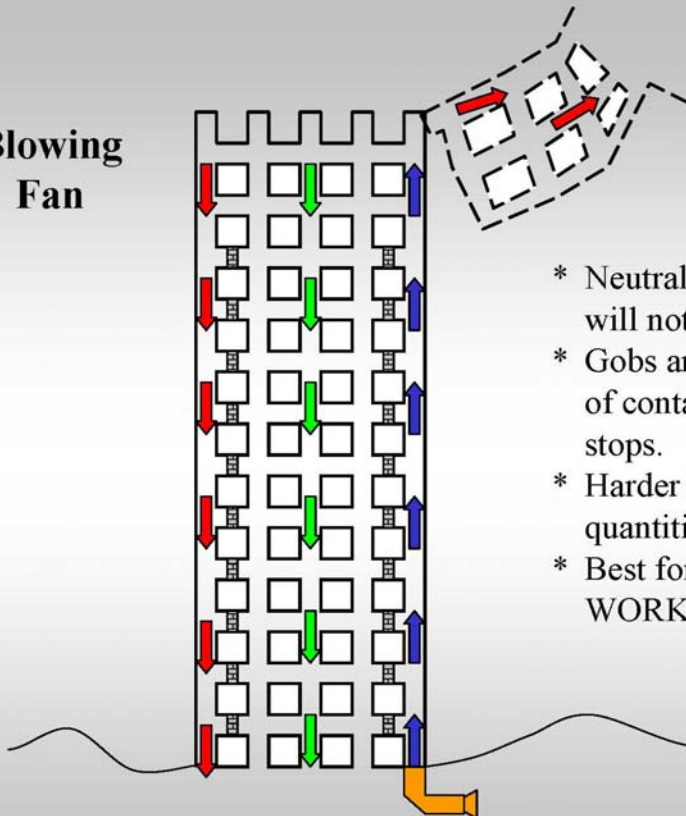

- * Neutral flows to outside. Smoke will not travel to face area.
- * Gobs are “pressurized”. Less influx of contaminants from gobs until fan stops.
- * Harder to maintain required LOC quantities.
- * Best for mining near OLD WORKS.

9

Exhausting Fan

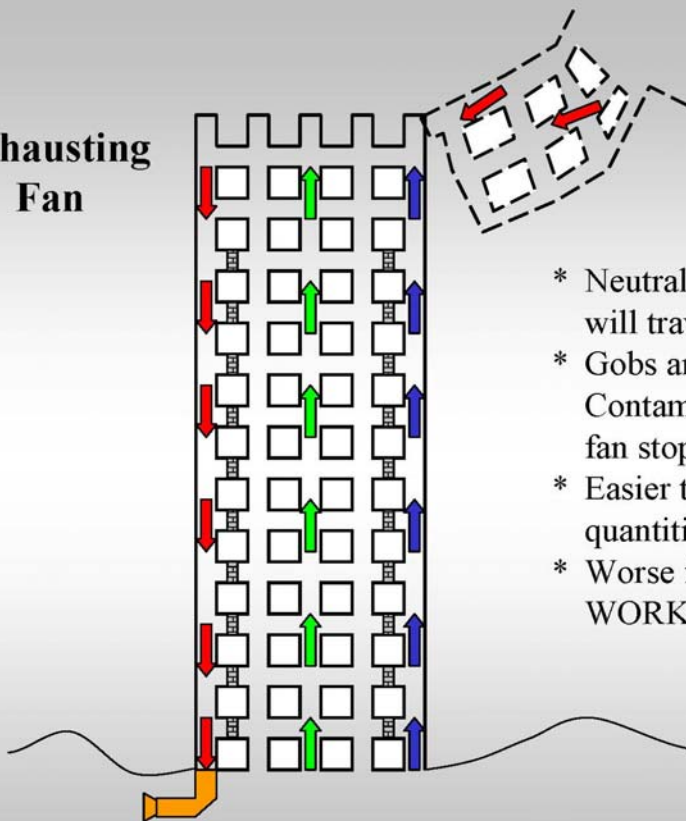

- * Neutral flows toward face. Smoke will travel toward face area.
- * Gobs are “under suction”. Contaminants flow from gobs until fan stops.
- * Easier to maintain required LOC quantities.
- * Worse for mining near OLD WORKS.

10

Face Ventilation

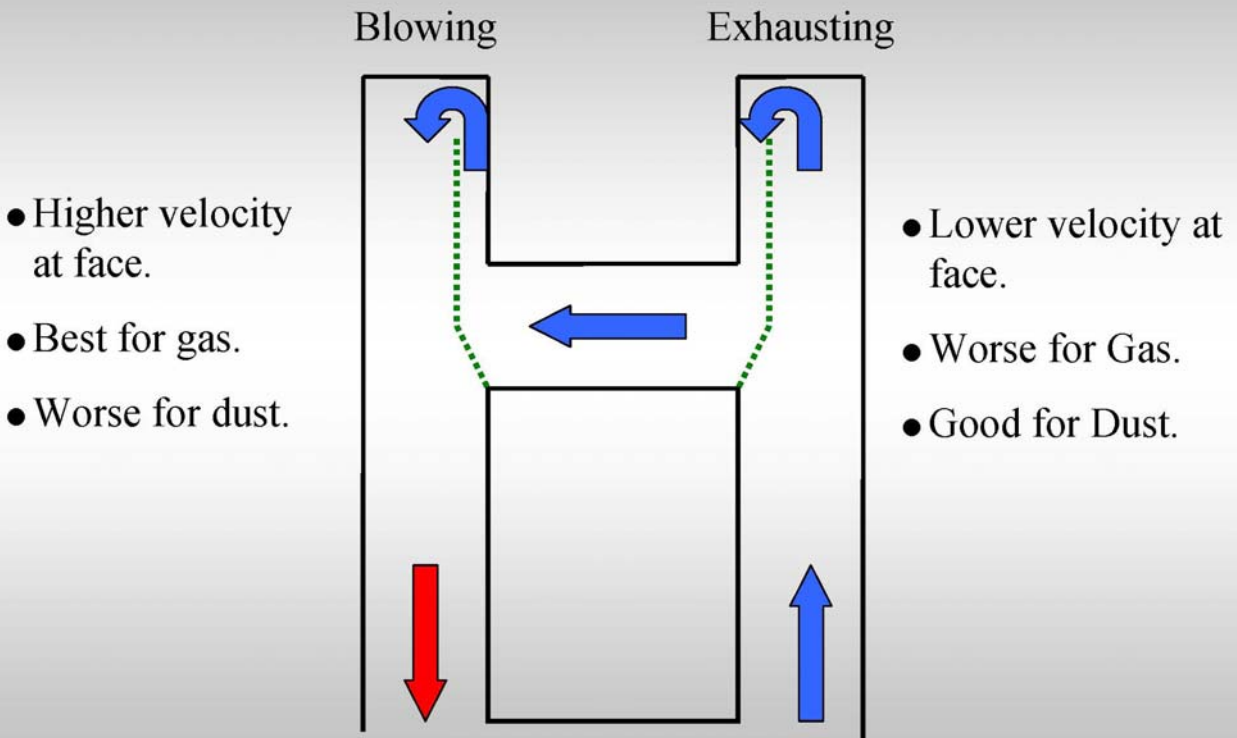

11

Check Curtains

- **A great deal of air leakage occurs on working sections.**
- **Properly installed and maintained check curtains are very important to prevent loss of large quantities of air between the last permanent stopping(s) and the working face.**

Check Curtains

- **Before installing a check curtain , the entire entry should be thoroughly inspected for uneven loose roof, haulage hazards, ribs or protruding brows.**
- **Equipment or other obstacles should never be parked or placed close to check curtains.**

13

Face Ventilation

Get the air where you need it!

- **Ensure check curtains are tight**
- **Good Run Through Curtains**
- **Do not Park Equipment in Last Open Entries**
- **Keep curtains close to the face**

14

Proper installation procedures

- **Curtain needs to remain free of holes and rips**
- **Adequate length and width are imperative**
- **Overlap curtains when more than one piece is required**

15

When using line brattice systems, exhausting line brattice may not deliver quite as much air to the face as blowing line brattice.

Question: Why does this happen?

Answer: Air always flows from a higher pressure to a lower pressure.

When exhausting line brattice is used, the area behind the brattice (or curtain) is on the downstream (low pressure) side.

This causes the curtain to belly (balloon) in toward the rib - because air is trying to get from the wide (high pressure) side of the entry to the tight (low pressure) side of the entry behind the curtain.

Reducing the ventilation area behind the line curtain.

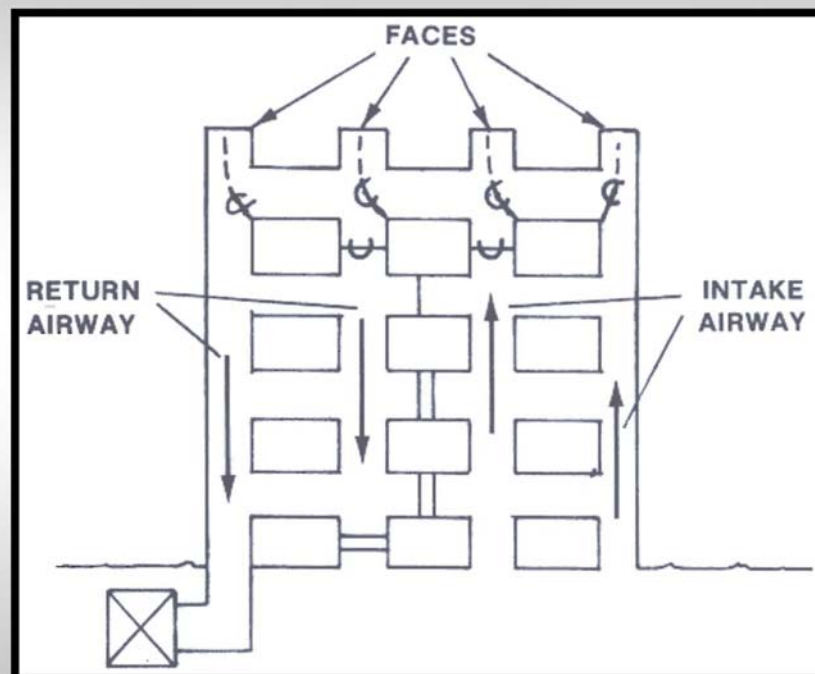

Permanent Stopping

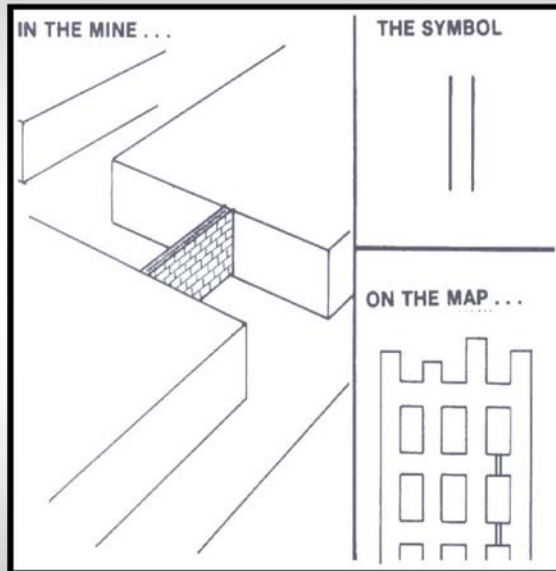

19

Check Curtain

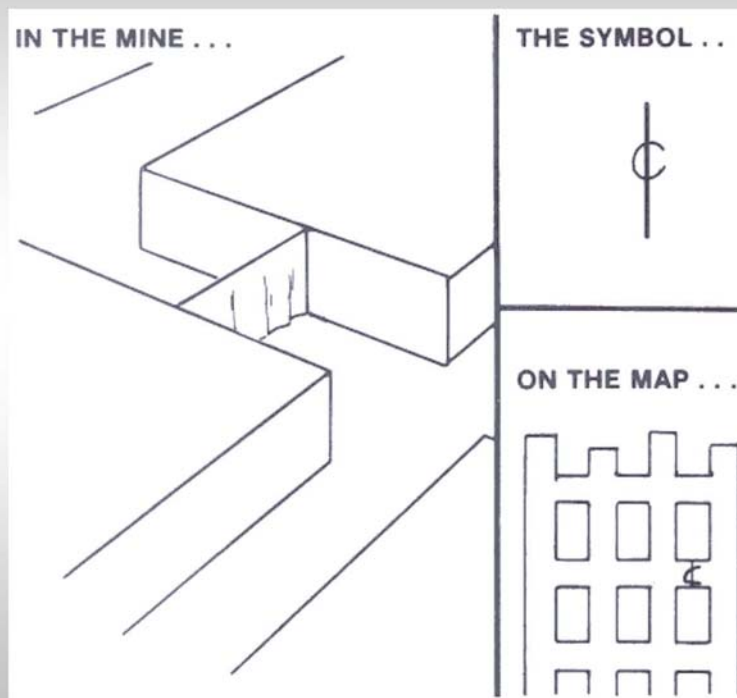

20

Single Split System

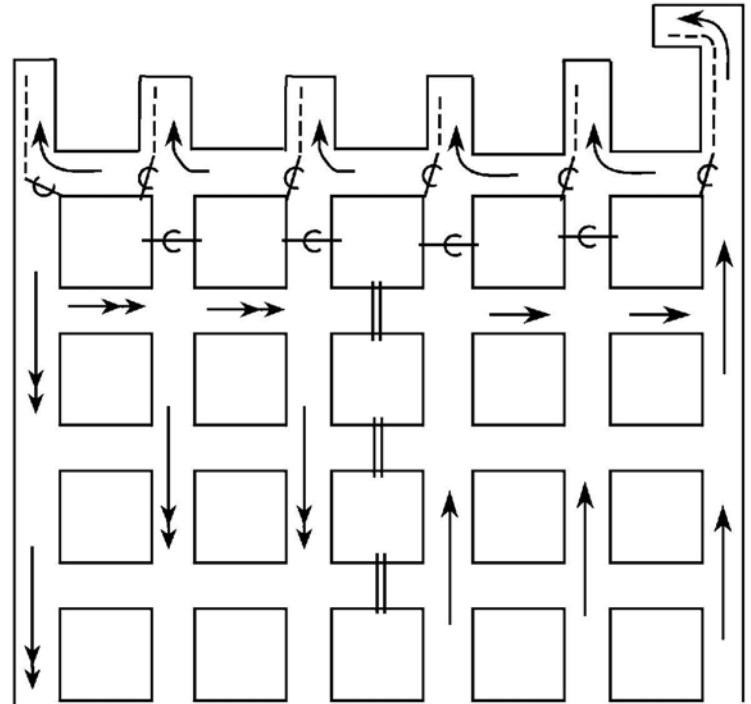

21

Double Split System

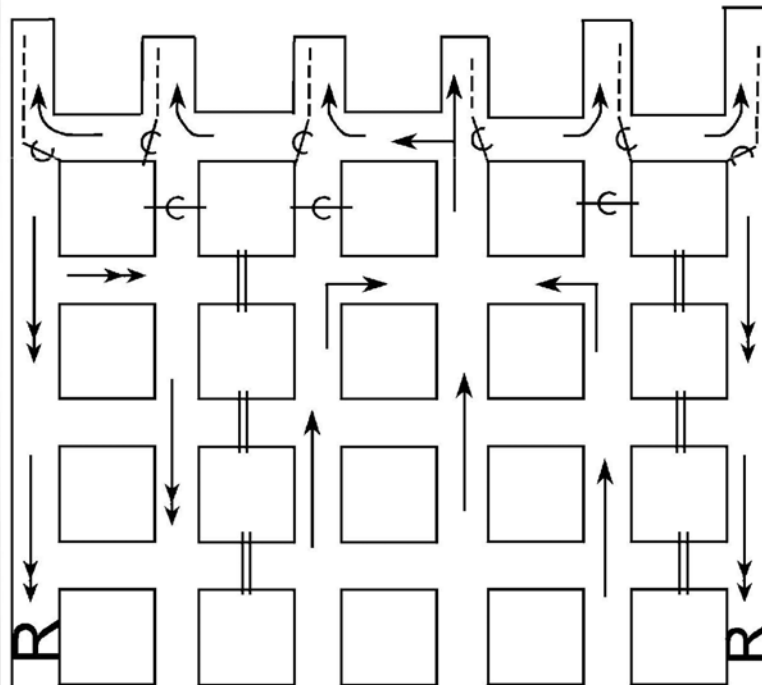

22

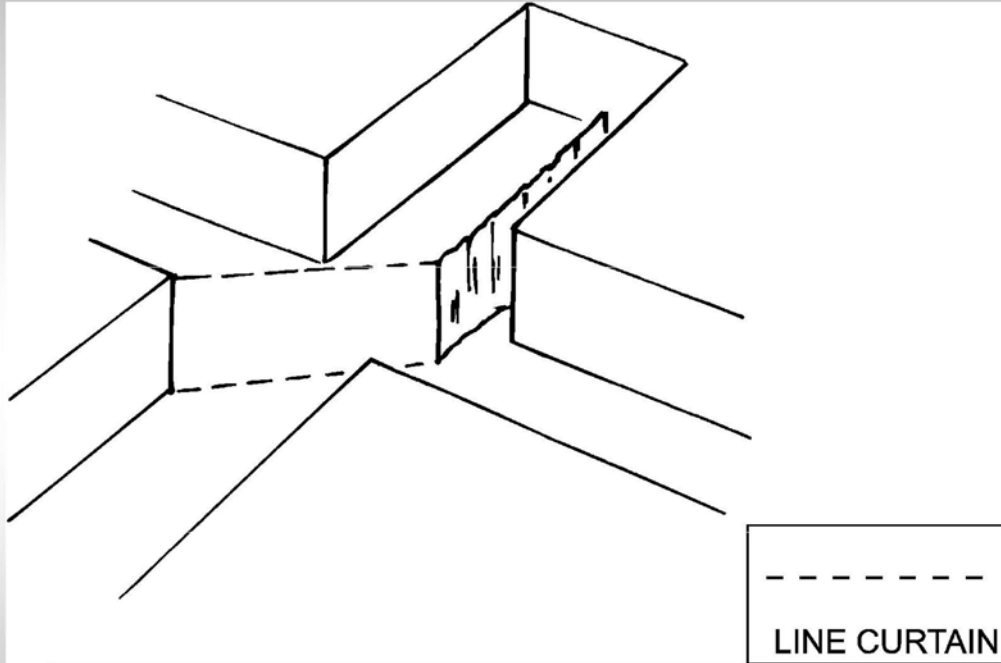

23

Ventilation of Idle Working Places with Line Brattice

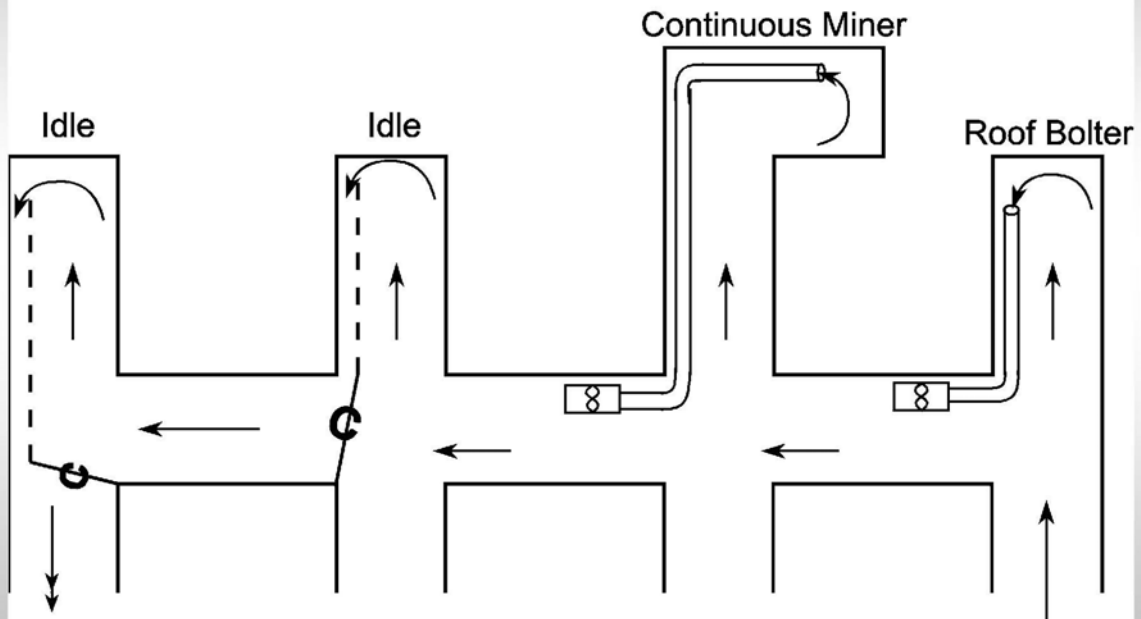

24

Sweep Ventilation

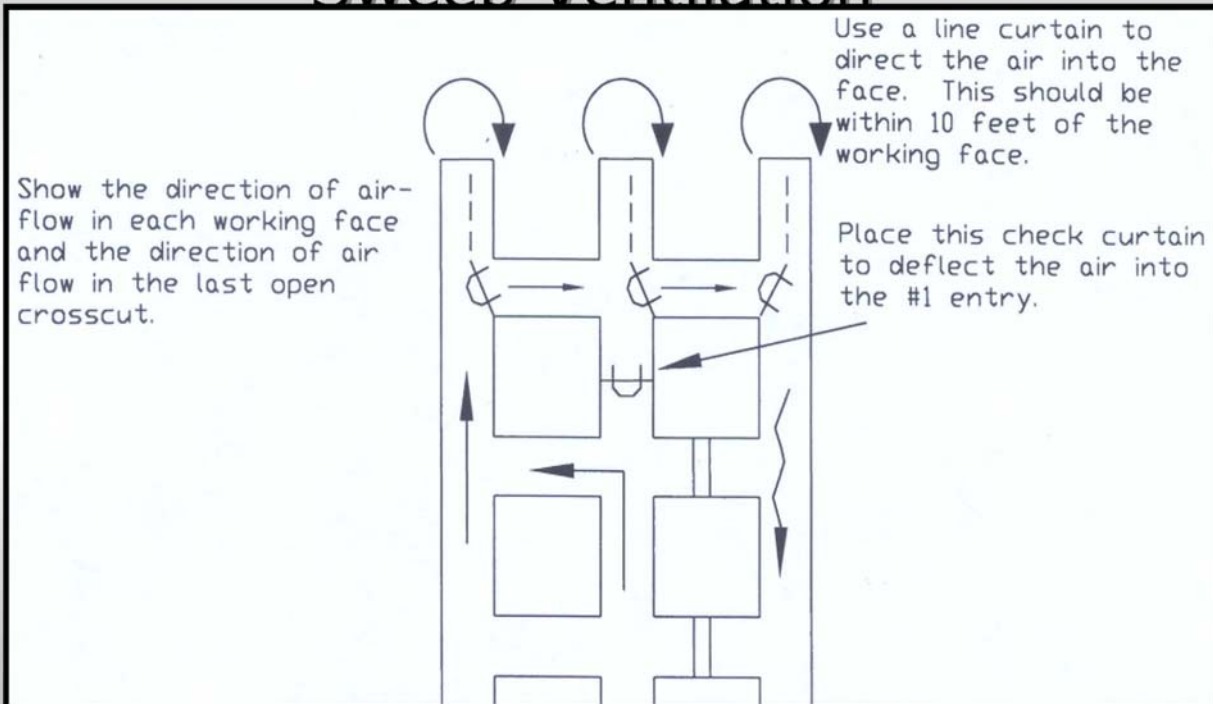

Section 75. 325. Volume of Air.

- The quantity of air reaching each working face where coal is being cut, mined, drilled for blasting, or loaded shall be at least 3,000 cubic feet per minute unless a greater quantity is required in the approved ventilation plan.
- The quantity of air passing through the last open crosscut shall be at least 9,000 cubic feet per minute unless a greater quantity is required in the approved ventilation plan.
- The air current at working faces shall under all conditions have a sufficient quantity to dilute, render harmless, and carry away flammable, explosive, noxious, and harmful gasses, dusts, smoke, and fumes, this quantity shall be specified in the approved ventilation plan.

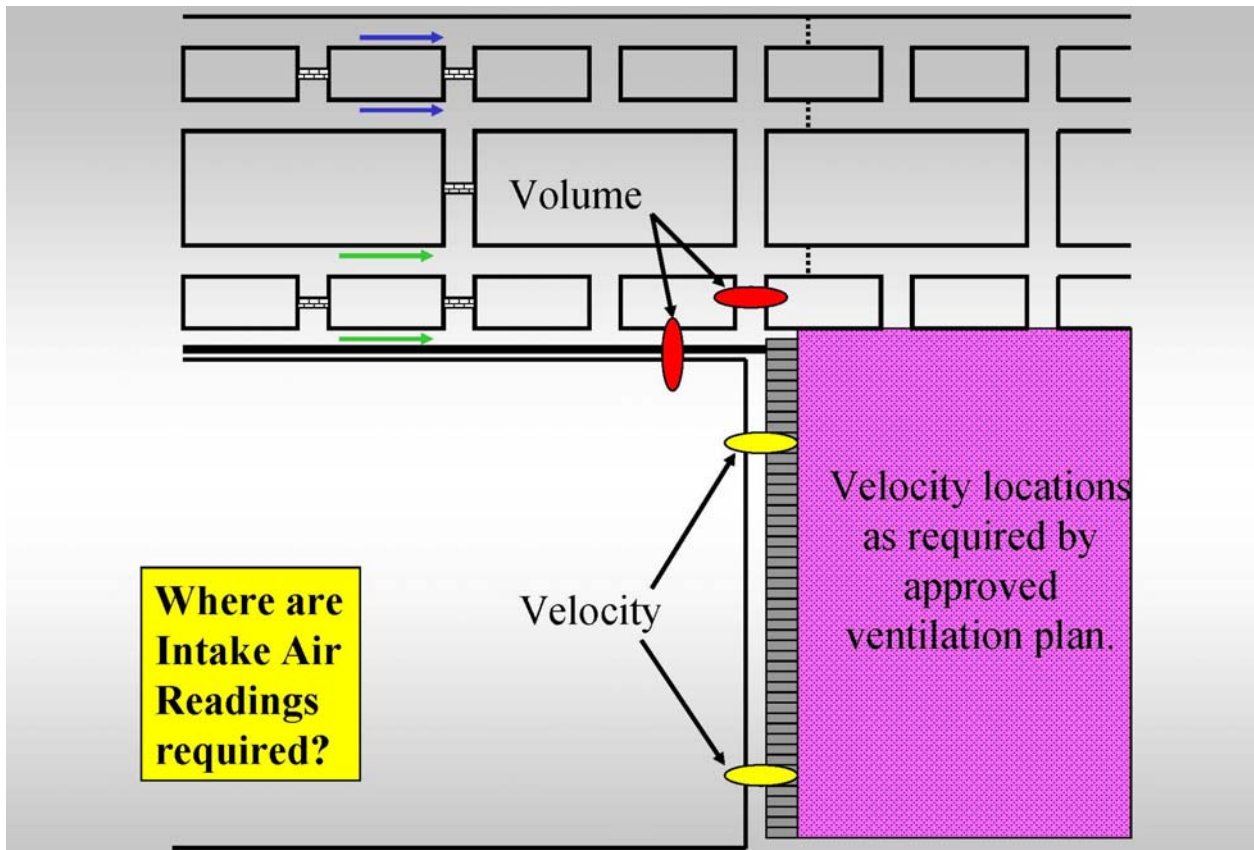

27

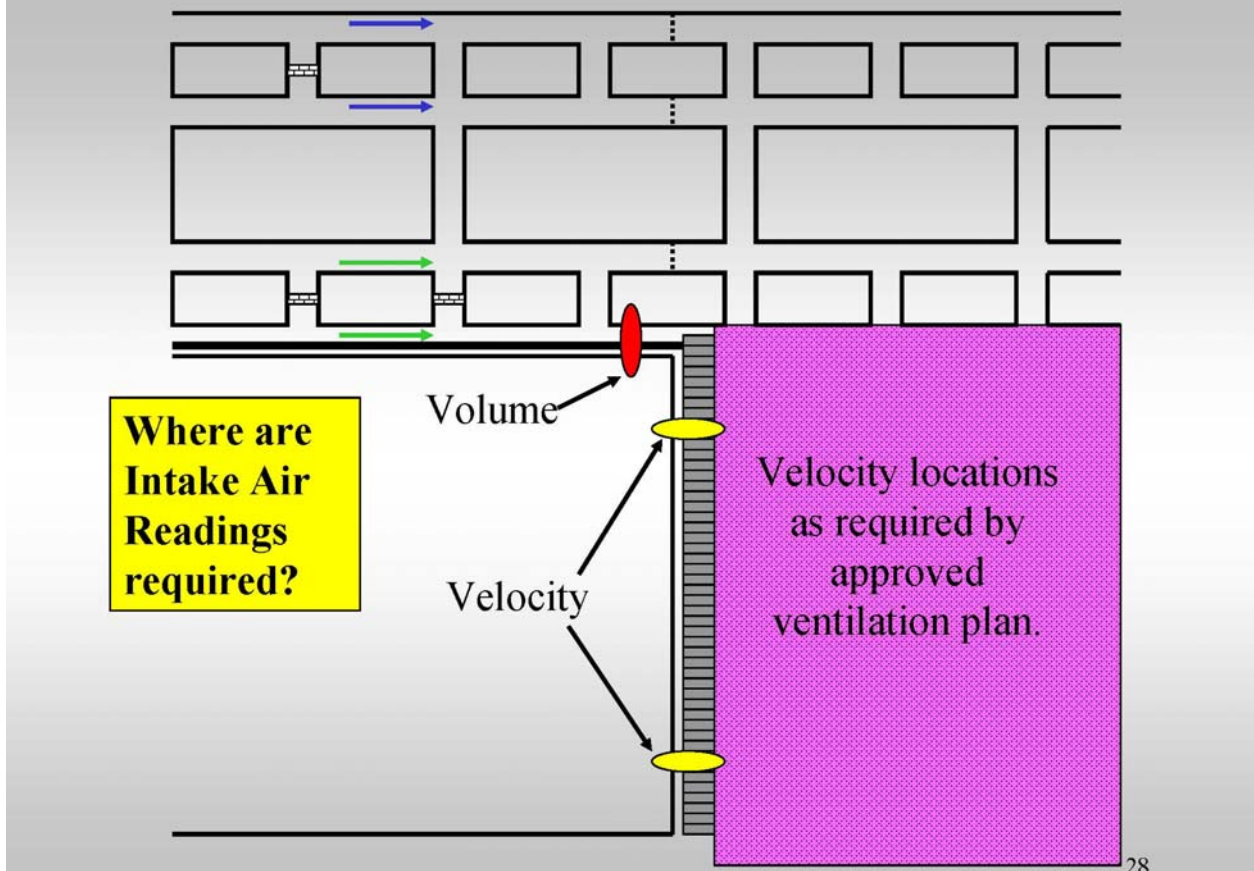

28

- **On shift respirable dust control parameters.**
- The examination shall include air quantity and velocities, water pressures and flow rates, excessive leakage in the water delivery system, water spray numbers and orientations, section ventilation and control device placement and any other dust suppression measures required by the ventilation plan.
- If scrubbers are used the plan shall specify the operating parameters.

29

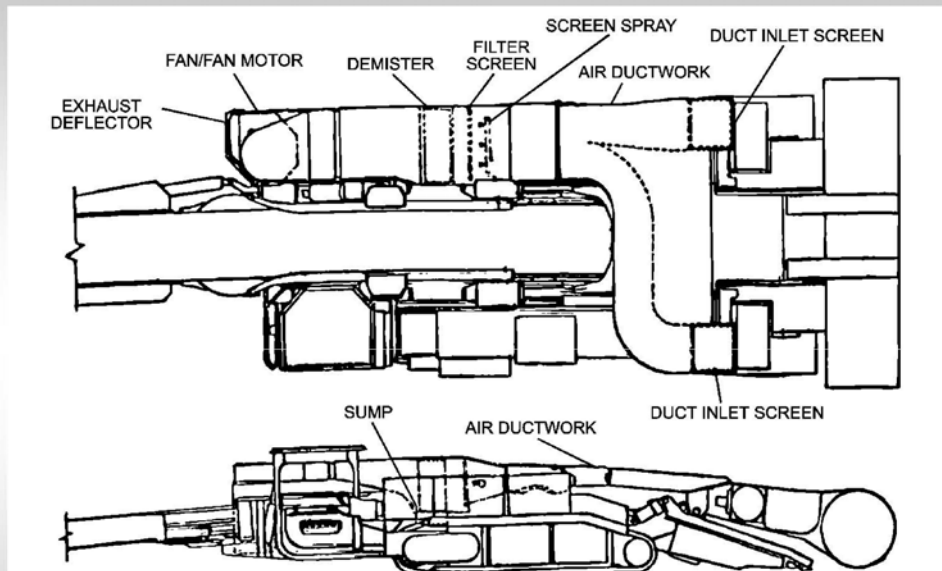

30

Scrubbers

- Introduction of Scrubbers allowed Deeper Cuts using both Blowing and Exhausting Ventilation Systems
- 40 feet Deep Cuts became common as long as Methane and Dust was controlled

31

What Should Your Line Brattice Air Quantity Be?

- Balance Line Brattice Air Quantity with the Scrubber Air Quantity
- **Typically this quantity is +/- 1,000 cfm of scrubber capacity**
 - **Scrubber Capacity**
 - Name Plate Rated Capacity (Manufacturer)
 - » Air Densities
 - » Voltages
 - » Power Factors
 - » Dry vrs. wet
 - Actual Capacity
 - » Clean
 - » Dirty
 - » Variations due to wear and tear or changes
- **Need Proper Scrubber Air Quantity to Determine Line Brattice Air Quantity**

32

What Should the Line Brattice Air Quantity Be

- Typically this quantity is +/- 1,000 cfm of scrubber capacity
 - Tech support advises this quantity can be greater than +1,000 cfm of scrubber capacity
 - Upper limit only if conditions exist that overpower scrubber
 - 400 fpm
 - Curtain close to the cutting face
- Take Air Reading with Scrubber Off!!!!

33

Brattice Air Quantity Higher than Scrubber Air Quantity

Additional Air Quantity helps to Dilute Downwind Concentrations

Keep Velocities Below 400 fpm

Curtain is not to close to Cutting Head

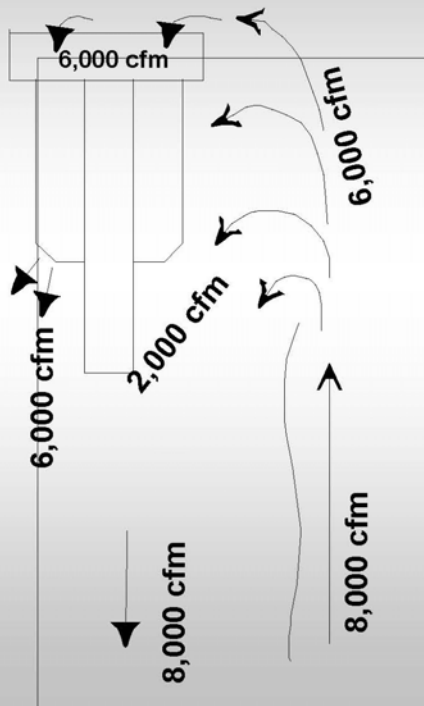

34

Higher Air Quantities

400 fpm

800 fpm

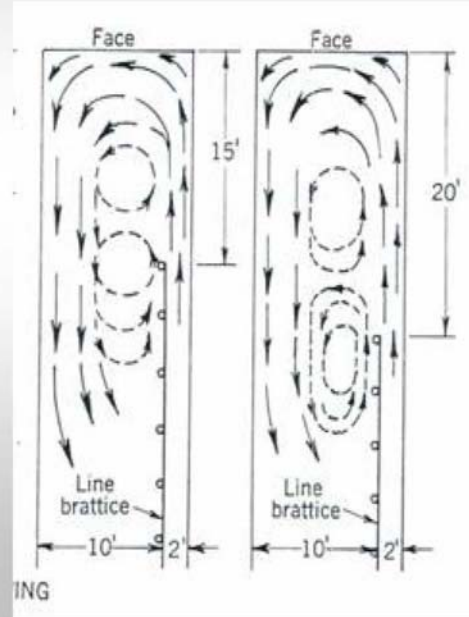
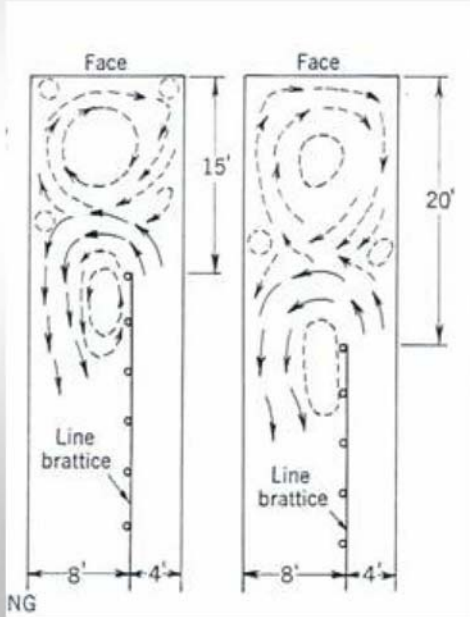

**Scrubber Over Powered if
Line Brattice Quantity
exceeds Scrubber Quantity
or
High Velocity**

**Effects Ram Car
Operators &
Downwind
Personnel (Roof
Bolters)**

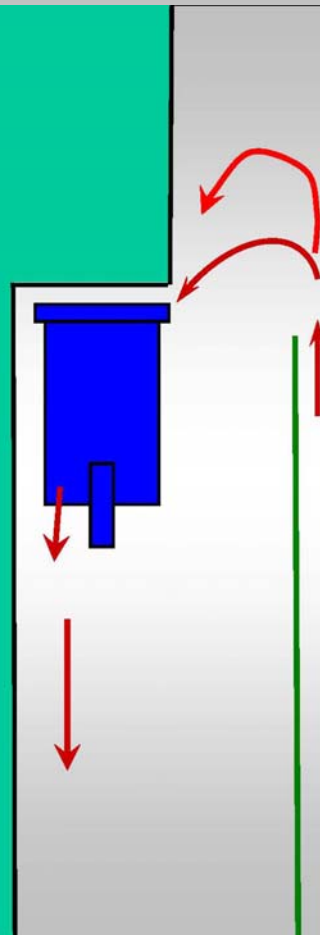

**Curtain close to
cutting head
Velocity exceeds
400 fpm**

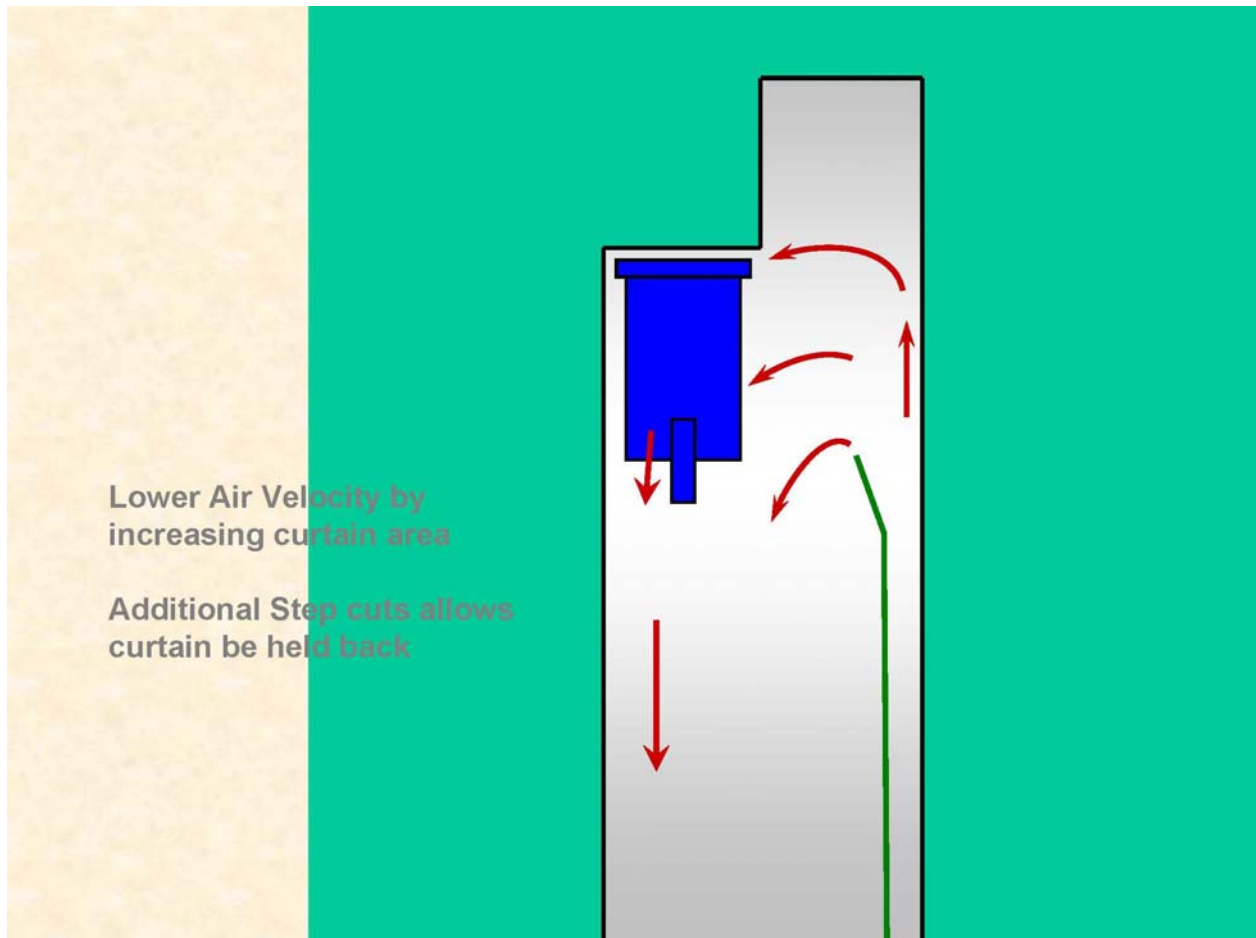

- **Air Quantity Reading should be taken with the scrubber off!!!!**

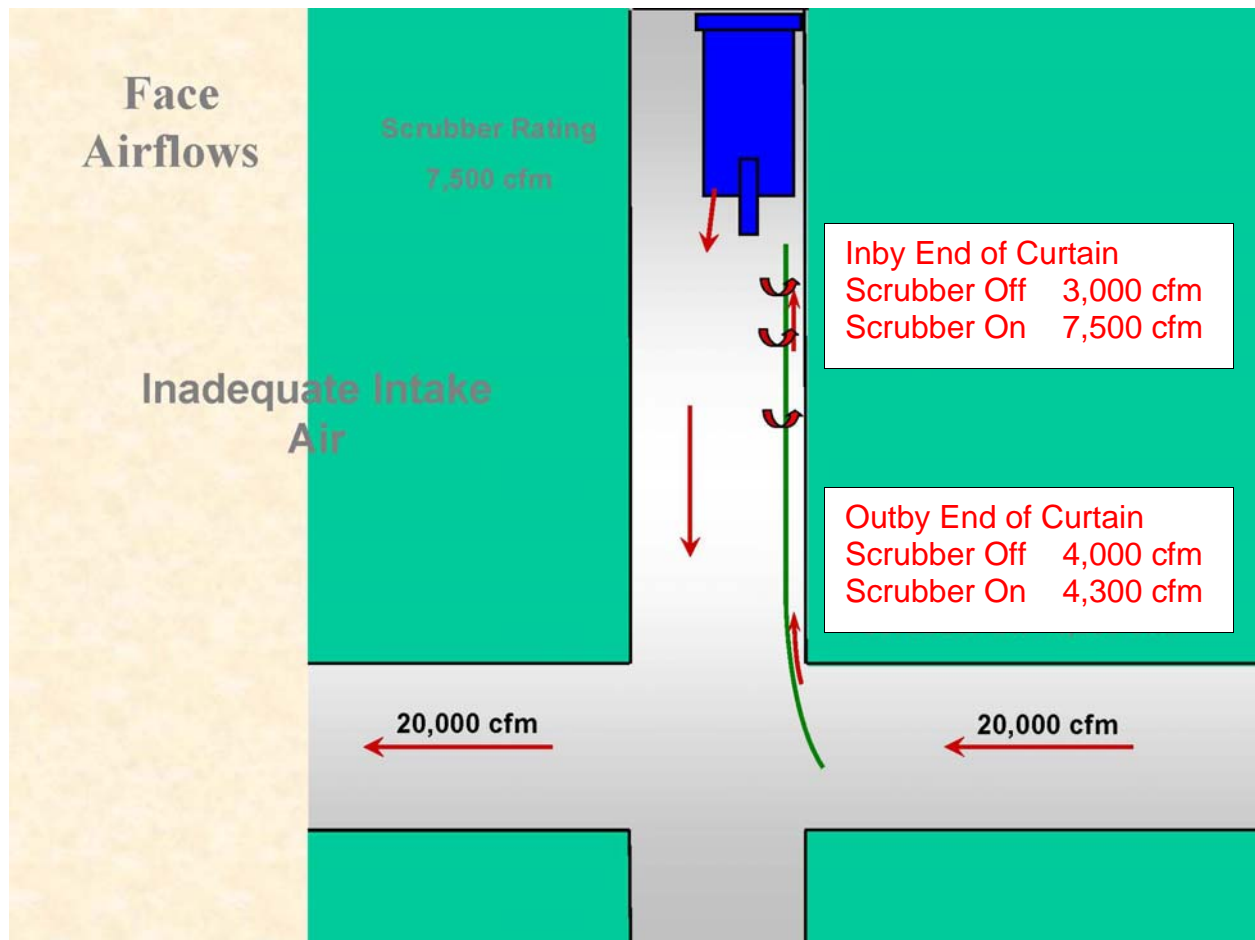

Other Factors Influencing Line Curtain Air Quantities

- Movement through Outby Curtains or manddoors
- Position of other Equipment
- Movement of Outby Equipment
- Person taking the Air Reading

AUXILIARY FANS AND TUBING

§ 75.331

- Permissible
- Maintained in proper operating condition
- Deenergized when no one is present on the section
- Deficiency corrected immediately
- Deenergized for one percent or more methane

§ 75.331 (continued)

When auxiliary fan is stopped

- Ventilation to faces maintained by other means
- Electrical equipment disconnected at power source
- Mechanized equipment shut off

Auxiliary fans located and operated to avoid recirculation of air

WORKING SECTIONS AND WORKING PLACES

§ 75.332

Separate intake split for each

- Working section
- Area where equipment is being installed or removed
- Set of equipment simultaneously mining on same working section

§ 75.332 (continued)

Prohibits use of air to ventilate a working place if air has passed

- Through any area
 - Not examined under § 75.360, § 75.361 or § 75.364, or
 - Second mining has been done
- By an opening of unsealed area
 - Not examined under § 75.360, § 75.361 or § 75.364

Section 75.323(a). Actions for excessive methane.

- Tests for methane concentration under this section shall be made by certified or qualified persons trained in the use of an approved detecting device which is properly calibrated. Tests shall be made at least twelve inches from the roof, face, ribs, and floor.

46

Section 75.323(b). Actions for excessive methane.

- When one percent or more methane is present in a working place or an intake air course, including an air course in which a belt conveyor is located, or in an area where mining equipment is being installed or removed, work shall cease and electrical power shall be de-energized in the affected area except intrinsically safe atmospheric monitoring systems (AMS).

47

1. Stop Work in No. 2
2. Kill Power to Affected Electric Face Equipment.

Methane Example

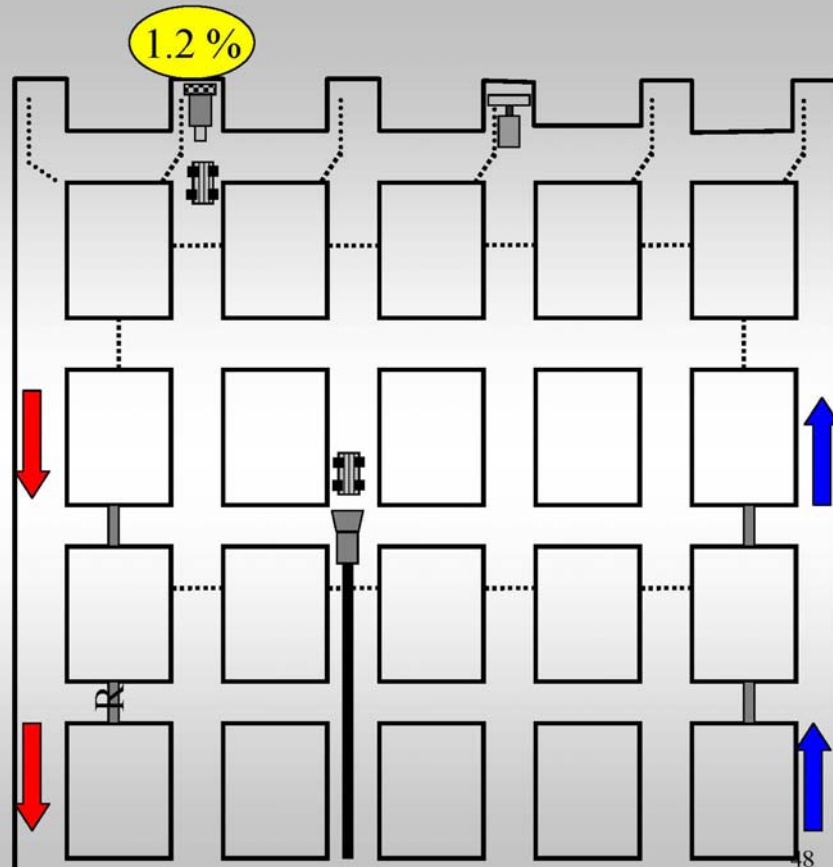

Section 75.323(b). Actions for excessive methane.

- Changes or adjustments shall be made to the ventilation system to reduce the concentration to less than one percent. *Only work to reduce the concentration of methane below one percent shall be permitted.*

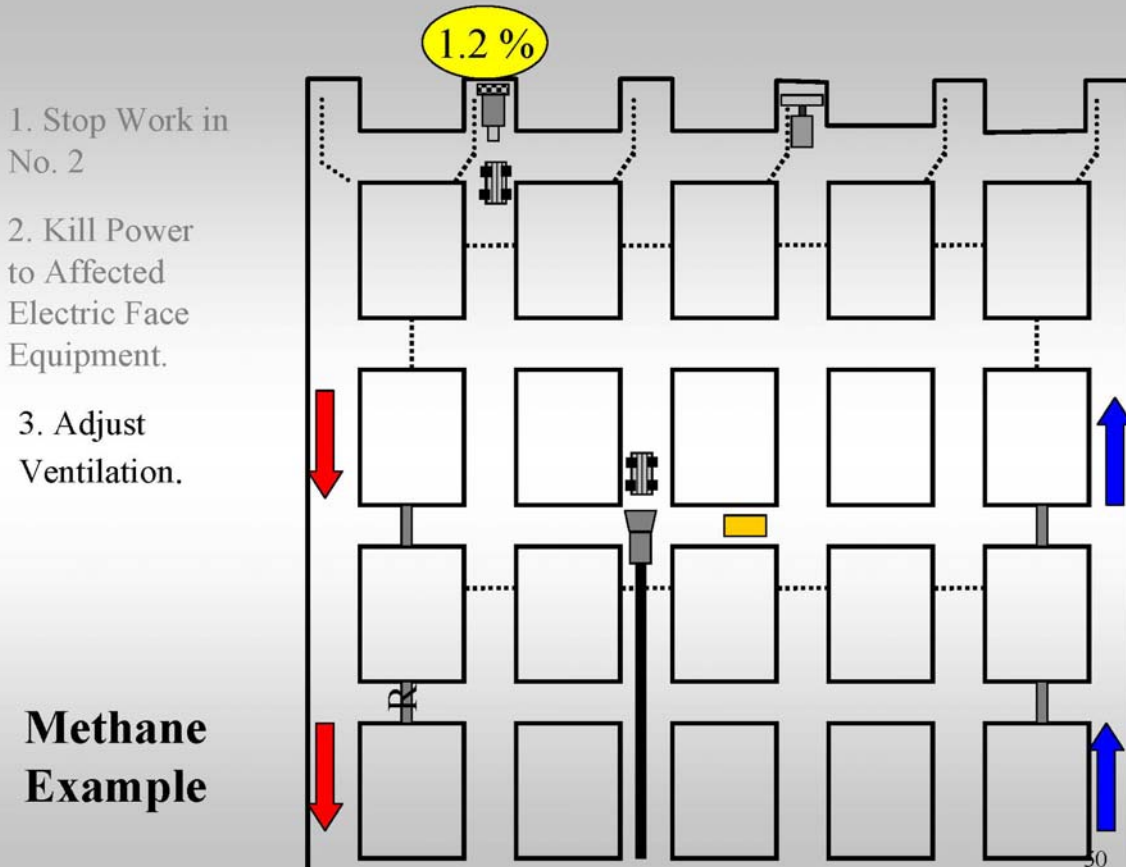

Section 75.323(b). Actions for excessive methane continued.

- When one and one-half percent or more methane is present in a working place or an intake air course, including an air course in which a belt conveyor is located, or an area where mining equipment is being installed or removed, only work necessary to reduce the methane concentration to less than one and one-half percent will be permitted and all other personnel shall be withdrawn from the affected area.
- Electrically powered equipment in the affected area shall be de-energized and other mechanized equipment shall be shut off except of intrinsically safe atmospheric monitoring systems (AMS).

1. Work to reduce CH₄ concentration.
2. Withdraw all other personnel.
3. De-energize power center.

Methane Example

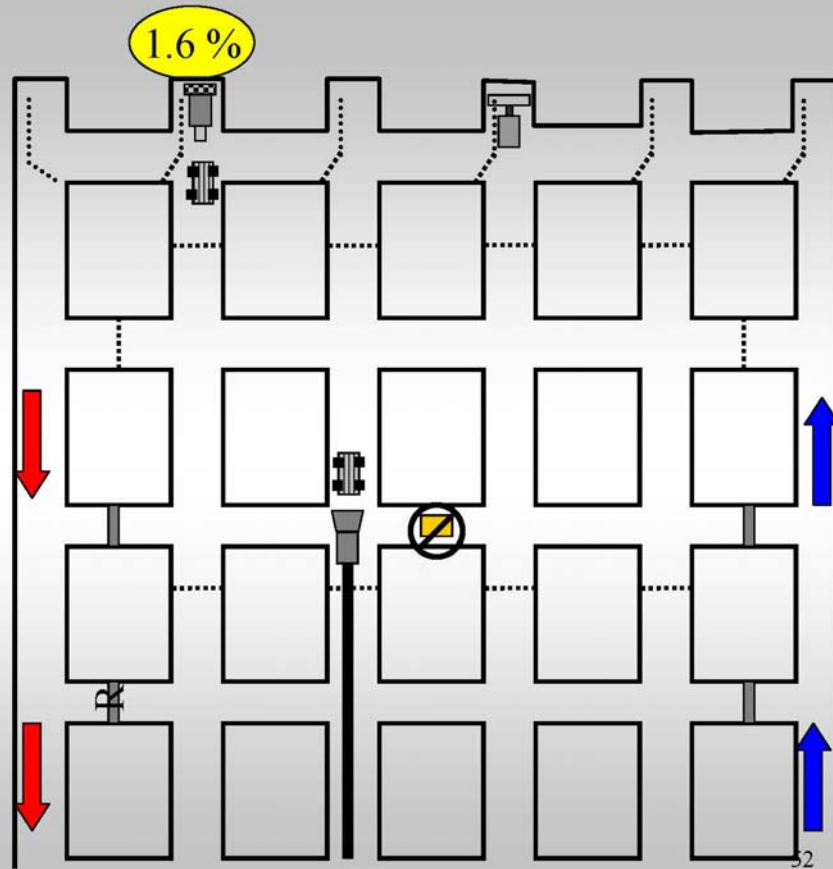

Rock Dusting

- Generous applications of rock dust can prevent the propagation of coal dust explosions.
- The standards require that all areas of a coal mine that can be safely traveled must be kept adequately rock dusted to within 40 feet of all working faces
- Section 75.403 requires that rock dust be applied to the top, floor and sides of all underground areas of a coal mine and maintained in such quantities that the incombustible content be not less than 65 percent in intakes and 80 percent in returns. When methane is present in the ventilating air current the percent of incombustible content shall be increased. Recent NIOSH studies indicate that the incombustible content in intakes should be increased to 80 percent due to the use of modern mechanized mining equipment which generates smaller size dust particles.

Permissible Electric Equipment

- In order to prevent methane ignitions caused by electrical equipment, all such equipment taken into or used in by the last open crosscut, in return air or located within 150 feet of pillar workings or longwall faces must be maintained in permissible condition

54

The End

55



Title 30

Code of Federal Regulation

Subpart D - Ventilation

30 CFR § 75.301

Definitions.

In addition to the applicable definitions in [§75.2](#), the following definitions apply in this subpart.

Air course. An entry or a set of entries separated from other entries by stoppings, overcasts, other ventilation control devices, or by solid blocks of coal or rock so that any mixing of air currents between each is limited to leakage.

AMS operator. The person(s), designated by the mine operator, who is located on the surface of the mine and monitors the malfunction, alert, and alarm signals of the AMS and notifies appropriate personnel of these signals.

Appropriate personnel. The person or persons designated by the operator to perform specific tasks in response to AMS signals. Appropriate personnel include the responsible person(s) required by § 75.1501 when an emergency evacuation is necessary.

Atmospheric Monitoring System (AMS). A network consisting of hardware and software meeting the requirements of §§ 75.351 and 75.1103-2 and capable of: measuring atmospheric parameters; transmitting the measurements to a designated surface location; providing alert and alarm signals; processing and cataloging atmospheric data; and, providing reports. Early-warning fire detection systems using newer technology that provides equal or greater protection, as determined by the Secretary, will be considered atmospheric monitoring systems for the purposes of this subpart.

Belt air course. The entry in which a belt is located and any adjacent entry(ies) not separated from the belt entry by permanent ventilation controls, including any entries in series with the belt entry, terminating at a return regulator, a section loading point, or the surface.

Carbon monoxide ambient level. The average concentration in parts per million (ppm) of carbon monoxide detected in an air course containing carbon monoxide sensors. This average concentration is representative of the composition of the mine atmosphere over a period of mining activity during non-fire conditions. Separate ambient levels may be established for different areas of the mine.

Incombustible. Incapable of being burned.

Intake air. Air that has not yet ventilated the last working place on any split of any working section, or any worked-out area, whether pillared or nonpillared.

Intrinsically safe. Incapable of releasing enough electrical or thermal energy under normal or abnormal conditions to cause ignition of a flammable mixture of methane or natural gas and air of the most easily ignitable composition.

Noncombustible Structure or Area. Describes a structure or area that will continue to provide protection against flame spread for at least 1 hour when subjected to a fire test incorporating an ASTM E119-88 time/temperature heat input, or equivalent. The publication ASTM E119-88, "Standard Test Methods for Fire Tests of Building Construction and Materials" is incorporated by reference and may be inspected at any MSHA Coal Mine Safety and Health district office, or at MSHA's Office of Standards, Regulations, and Variances, 1100 Wilson Boulevard Room 2352, Arlington, Virginia 22209-3939, and at the Office of the Federal Register, 800 North Capitol Street, NW., Suite 700, Washington, DC. In addition, copies of the document can be purchased from the American Society for Testing Materials (ASTM), 1916 Race Street, Philadelphia, Pennsylvania 19103. This incorporation by reference was approved by the Director of the Federal Register in accordance with 5 U.S.C. 552(a) and 1 CFR part 51.

Noncombustible Material. Describes a material which when used to construct a ventilation control results in a control that will continue to serve its intended function for 1 hour when subjected to a fire test incorporating an ASTM E119-88 time/temperature heat input, or equivalent. The publication ASTM E119-88, "Standard Test Methods for Fire Tests of Building Construction and Materials" is incorporated by reference and may be inspected at any MSHA Coal Mine Safety and Health district office, or at MSHA's Office of Standards, Regulations, and Variances, Regulations, and Variances, 1100 Wilson Boulevard, Arlington, VA, and at the Office of the Federal Register, 800 North Capitol Street, NW., Suite 700, Washington, DC. In addition, copies of the document can be purchased from the American Society for Testing Materials (ASTM), 100 Barr Harbor Drive, PO Box C700, West Conshohocken, PA 19428-2959; <http://www.astm.org>. This incorporation by reference was approved by the Director of the Federal Register in accordance with 5 U.S.C. 552(a) and 1 CFR part 51.

Point feeding. The process of providing additional intake air to the belt air course from another intake air course through a regulator.

Return air. Air that has ventilated the last working place on any split of any working section or any worked-out area whether pillared or nonpillared. If air mixes with air that has ventilated the last working place on any split of any working section or any worked-out area, whether pillared or nonpillared, it is considered return air. For the purposes of [§75.507-1](#), air that has been used to ventilate any working place in a coal producing section or pillared area, or air that has been used to ventilate any working face if such air is directed away from the immediate return is return air. Notwithstanding the definition of intake air, for the purpose of ventilation of structures, areas or installations that are required by this subpart D to be ventilated to return air courses, and for ventilation of seals, other air courses may be designated as return air courses by the operator only when the air in these air courses will not be used to ventilate working places or other locations, structures, installations or areas required to be ventilated with

intake air.

Worked-out area. An area where mining has been completed, whether pillared or nonpillared, excluding developing entries, return air courses, and intake air courses..

30 CFR § 75.320

Air quality detectors and measurement devices.

(a) Tests for methane shall be made by a qualified person with MSHA approved detectors that are maintained in permissible and proper operating condition and calibrated with a known methane-air mixture at least once every 31 days.

(b) Tests for oxygen deficiency shall be made by a qualified person with MSHA approved oxygen detectors that are maintained in permissible and proper operating condition and that can detect 19.5 percent oxygen with an accuracy of ± 0.5 percent. The oxygen detectors shall be calibrated at the start of each shift that the detectors will be used.

(c) Handheld devices that contain electrical components and that are used for measuring air velocity, carbon monoxide, oxides of nitrogen, and other gases shall be approved and maintained in permissible and proper operating condition.

(d) An oxygen detector approved by MSHA shall be used to make tests for oxygen deficiency required by the regulations in this part. Permissible flame safety lamps may only be used as a supplementary testing device.

(e) Maintenance of instruments required by paragraphs (a) through (d) of this section shall be done by persons trained in such maintenance.

30 CFR § 75.321

Air quality.

(a) The air in areas where persons work or travel, except as specified in paragraph

(a)(2) of this section, shall contain at least 19.5 percent oxygen and not more than 0.5 percent carbon dioxide, and the volume and velocity of the air current in these areas shall be sufficient to dilute, render harmless, and carry away flammable, explosive, noxious, and harmful gases, dusts, smoke, and fumes.

(2) The air in areas of bleeder entries and worked-out areas where persons work or travel shall contain at least 19.5 percent oxygen, and carbon dioxide levels shall not exceed 0.5 percent time weighted average and 3.0 percent short term exposure limit.

(b) Notwithstanding the provisions of [§75.322](#), for the purpose of preventing explosions from gases other than methane, the following gases shall not be permitted to accumulate in excess of the concentrations listed below:

(1) Carbon monoxide (CO)--2.5 percent

(2) Hydrogen (H(sub)2)--.80 percent

- (3) Hydrogen sulfide (H₂S)--.80 percent
- (4) Acetylene (C₂H₂)--.40 percent
- (5) Propane (C₃H₈)--.40 percent
- (6) MAPP (methyl-acetylene-propylene-propodiene)--.30 percent

30 CFR § 75.323

Actions for excessive methane.

(a) *Location of tests.* Tests for methane concentrations under this section shall be made at least 12 inches from the roof, face, ribs, and floor.

(b) *Working places and intake air courses.*

(1) When 1.0 percent or more methane is present in a working place or an intake air course, including an air course in which a belt conveyor is located, or in an area where mechanized mining equipment is being installed or removed--

(i) Except intrinsically safe atmospheric monitoring systems (AMS), electrically powered equipment in the affected area shall be deenergized, and other mechanized equipment shall be shut off;

(ii) Changes or adjustments shall be made at once to the ventilation system to reduce the concentration of methane to less than 1.0 percent; and

(iii) No other work shall be permitted in the affected area until the methane concentration is less than 1.0 percent.

(2) When 1.5 percent or more methane is present in a working place or an intake air course, including an air course in which a belt conveyor is located, or in an area where mechanized mining equipment is being installed or removed--

(i) Everyone except those persons referred to in §104(c) of the Act shall be withdrawn from the affected area; and

(ii) Except for intrinsically safe AMS, electrically powered equipment in the affected area shall be disconnected at the power source.

(c) *Return air split.* (1) When 1.0 percent or more methane is present in a return air split between the last working place on a working section and where that split of air meets another split of air, or the location at which the split is used to ventilate seals or worked-out areas changes or adjustments shall be made at once to the ventilation system to reduce the concentration of methane in the return air to less than 1.0 percent.

(2) When 1.5 percent or more methane is present in a return air split between the last working place on a working section and where that split of air meets another split of air,

or the location where the split is used to ventilate seals or worked-out areas--

(i) Everyone except those persons referred to in §104(c) of the Act shall be withdrawn from the affected area;

(ii) Other than intrinsically safe AMS, equipment in the affected area shall be deenergized, electric power shall be disconnected at the power source, and other mechanized equipment shall be shut off; and

(iii) No other work shall be permitted in the affected area until the methane concentration in the return air is less than 1.0 percent.

(d) *Return air split alternative.* (1) The provisions of this paragraph apply if--

(i) The quantity of air in the split ventilating the active workings is at least 27,000 cubic feet per minute in the last open crosscut or the quantity specified in the approved ventilation plan, whichever is greater;

(ii) The methane content of the air in the split is continuously monitored during mining operations by an AMS that gives a visual and audible signal on the working section when the methane in the return air reaches 1.5 percent, and the methane content is monitored as specified in [§75.351](#); and

(iii) Rock dust is continuously applied with a mechanical duster to the return air course during coal production at a location in the air course immediately outby the most inby monitoring point.

(2) When 1.5 percent or more methane is present in a return air split between a point in the return opposite the section loading point and where that split of air meets another split of air or where the split of air is used to ventilate seals or worked-out areas--

(i) Changes or adjustments shall be made at once to the ventilation system to reduce the concentration of methane in the return air below 1.5 percent;

(ii) Everyone except those persons referred to in §104(c) of the Act shall be withdrawn from the affected area;

(iii) Except for intrinsically safe AMS, equipment in the affected area shall be deenergized, electric power shall be disconnected at the power source, and other mechanized equipment shall be shut off; and

(iv) No other work shall be permitted in the affected area until the methane concentration in the return air is less than 1.5 percent.

(e) *Bleeders and other return air courses.* The concentration of methane in a bleeder split of air immediately before the air in the split joins another split of air, or in a return air course other than as described in paragraphs (c) and (d) of this section, shall not exceed 2.0 percent.

30 CFR § 75.324

Intentional changes in the ventilation system.

(a) A person designated by the operator shall supervise any intentional change in ventilation that--

(1) Alters the main air current or any split of the main air current in a manner that could materially affect the safety or health of persons in the mine; or

(2) Affects section ventilation by 9,000 cubic feet per minute of air or more in bituminous or lignite mines, or 5,000 cubic feet per minute of air or more in anthracite mines.

(b) Intentional changes shall be made only under the following conditions:

(1) Electric power shall be removed from areas affected by the ventilation change and mechanized equipment in those areas shall be shut off before the ventilation change begins.

(2) Only persons making the change in ventilation shall be in the mine.

(3) Electric power shall not be restored to the areas affected by the ventilation change and mechanized equipment shall not be restarted until a certified person has examined these areas for methane accumulation and for oxygen deficiency and has determined that the areas are safe.

30 CFR § 75.325

Air quantity.

(a)(1) In bituminous and lignite mines the quantity of air shall be at least 3,000 cubic feet per minute reaching each working face where coal is being cut, mined, drilled for blasting, or loaded. When a greater quantity is necessary to dilute, render harmless, and carry away flammable, explosive, noxious, and harmful gases, dusts, smoke, and fumes, this quantity shall be specified in the approved ventilation plan. A minimum air quantity may be required to be specified in the approved ventilation plan for other working places or working faces.

(2) The quantity of air reaching the working face shall be determined at or near the face end of the line curtain, ventilation tubing, or other ventilation control device. If the curtain, tubing, or device extends beyond the last row of permanent roof supports, the quantity of air reaching the working face shall be determined behind the line curtain or in the ventilation tubing at or near the last row of permanent supports.

(3) If machine mounted dust collectors or diffuser fans are used, the approved ventilation plan shall specify the operating volume of the dust collector or diffuser fan.

(b) In bituminous and lignite mines, the quantity of air reaching the last open crosscut of each set of entries or rooms on each working section and the quantity of air reaching the intake end of a pillar line shall be at least 9,000 cubic feet per minute unless a greater quantity is required to be specified in the approved ventilation plan. This

minimum also applies to sections which are not operating but are capable of producing coal by simply energizing the equipment on the section.

(c) In longwall and shortwall mining systems--

(1) The quantity of air shall be at least 30,000 cubic feet per minute reaching the working face of each longwall, unless the operator demonstrates that a lesser air quantity will maintain continual compliance with applicable methane and respirable dust standards. This lesser quantity shall be specified in the approved ventilation plan. A quantity greater than 30,000 cubic feet per minute may be required to be specified in the approved ventilation plan.

(2) The velocity of air that will be provided to control methane and respirable dust in accordance with applicable standards on each longwall or shortwall and the locations where these velocities will be provided shall be specified in the approved ventilation plan. The locations specified shall be at least 50 feet but no more than 100 feet from the headgate and tailgate, respectively.

(d) Ventilation shall be maintained during installation and removal of mechanized mining equipment. The approved ventilation plan shall specify the minimum quantity of air, the locations where this quantity will be provided and the ventilation controls required.

(e) In anthracite mines, the quantity of air shall be as follows:

(1) At least 1,500 cubic feet per minute reaching each working face where coal is being mined, unless a greater quantity is required to be specified in the approved ventilation plan.

(2) At least 5,000 cubic feet per minute passing through the last open crosscut in each set of entries or rooms and at the intake end of any pillar line, unless a greater quantity is required to be specified in the approved ventilation plan.

(3) When robbing areas where air currents cannot be controlled and air measurements cannot be obtained, the air shall have perceptible movement.

(f) The minimum ventilating air quantity for an individual unit of diesel-powered equipment being operated shall be at least that specified on the approval plate for that equipment. Such air quantity shall be maintained--

(1) In any working place where the equipment is being operated;

(2) At the section loading point during any shift the equipment is being operated on the working section;

(3) In any entry where the equipment is being operated outby the section loading point in areas of the mine developed on or after April 25, 1997;

(4) In any air course with single or multiple entries where the equipment is being operated outby the section loading point in areas of the mine developed prior to April

25, 1997; and

(5) At any other location required by the district manager and specified in the approved ventilation plan.

(g) The minimum ventilating air quantity where multiple units of diesel-powered equipment are operated on working sections and in areas where mechanized mining equipment is being installed or removed must be at least the sum of that specified on the approval plates of all the diesel-powered equipment on the working section or in the area where mechanized mining equipment is being installed or removed. The minimum ventilating air quantity shall be specified in the approved ventilation plan. For working sections such air quantity must be maintained--

(1) In the last open crosscut of each set of entries or rooms in each working section;

(2) In the intake, reaching the working face of each longwall; and

(3) At the intake end of any pillar line.

(h) The following equipment may be excluded from the calculations of ventilating air quantity under paragraph (g) if such equipment exclusion is approved by the district manager and specified in the ventilation plan:

(1) Self-propelled equipment meeting the requirements of [§ 75.1908\(b\)](#);

(2) Equipment that discharges its exhaust into intake air that is coursed directly to a return air course;

(3) Equipment that discharges its exhaust directly into a return air course; and

(4) Other equipment having duty cycles such that the emissions would not significantly affect the exposure of miners.

(i) A ventilating air quantity that is less than what is required by paragraph (g) of this section may be approved by the district manager in the ventilation plan based upon the results of sampling that demonstrate that the lesser air quantity will maintain continuous compliance with applicable TLV[®]'s.

(j) If during sampling required by [§ 70.1900\(c\)](#) of this subchapter the ventilating air is found to contain concentrations of CO or NO² in excess of the action level specified by § 70.1900(c), higher action levels may be approved by the district manager based on the results of sampling that demonstrate that a higher action level will maintain continuous compliance with applicable TLV[®]'s. Action levels other than those specified in § 70.1900(c) shall be specified in the approved ventilation plan.

(k) As of November 25, 1997 the ventilating air quantity required where diesel-powered equipment is operated shall meet the requirements of paragraphs (f) through (j) of this section. Mine operators utilizing diesel-powered equipment in underground coal mines shall submit to the appropriate MSHA district manager a revised ventilation plan or

appropriate amendments to the existing plan, in accordance with § 75.371, which implement the requirements of paragraphs (f) through (j) of this section.

30 CFR § 75.326

Mean entry air velocity.

In exhausting face ventilation systems, the mean entry air velocity shall be at least 60 feet per minute reaching each working face where coal is being cut, mined, drilled for blasting, or loaded, and to any other working places as required in the approved ventilation plan. A lower mean entry air velocity may be approved in the ventilation plan if the lower velocity will maintain methane and respirable dust concentrations below the applicable levels. Mean entry air velocity shall be determined at or near the inby end of the line curtain, ventilation tubing, or other face ventilation control devices.

30 CFR § 75.331

Auxiliary fans and tubing.

(a) When auxiliary fans and tubing are used for face ventilation, each auxiliary fan shall be--

- (1) Permissible, if the fan is electrically operated;
- (2) Maintained in proper operating condition;
- (3) Deenergized or shut off when no one is present on the working section; and
- (4) Located and operated to avoid recirculation of air.

(b) If a deficiency exists in any auxiliary fan system, the deficiency shall be corrected or the auxiliary fan shall be deenergized immediately.

(c) If the air passing through an auxiliary fan or tubing contains 1.0 percent or more methane, power to electrical equipment in the working place and to the auxiliary fan shall be deenergized, and other mechanized equipment in the working place shall be shut off until the methane concentration is reduced to less than 1.0 percent.

(d) When an auxiliary fan is stopped--

- (1) Line brattice or other face ventilation control devices shall be used to maintain ventilation to affected faces; and
- (2) Electrical equipment in the affected working places shall be disconnected at the power source, and other mechanized equipment shall be shut off until ventilation to the working place is restored.

30 CFR § 75.337

Construction and repair of seals.

(a) The mine operator shall maintain and repair seals to protect miners from hazards of sealed areas.

(b) Prior to sealing, the mine operator shall--

(1) Remove insulated cables, batteries, and other potential electric ignition sources from the area to be sealed when constructing seals, unless it is not safe to do so. If ignition sources cannot safely be removed, seals must be constructed to at least 120 psi;

(2) Remove metallic objects through or across seals; and

(3) Breach or remove all stoppings in the first crosscut inby the seals immediately prior to sealing the area.

(c) A certified person designated by the mine operator shall directly supervise seal construction and repair and--

(1) Examine each seal site immediately prior to construction or repair to ensure that the site is in accordance with the approved ventilation plan;

(2) Examine each seal under construction or repair during each shift to ensure that the seal is being constructed or repaired in accordance with the approved ventilation plan;

(3) Examine each seal upon completion of construction or repair to ensure that construction or repair is in accordance with the approved ventilation plan;

(4) Certify by initials, date, and time that the examinations were made; and

(5) Make a record of the examination at the completion of any shift during which an examination was conducted. The record shall include each deficiency and the corrective action taken. The record shall be countersigned by the mine foreman or equivalent mine official by the end of the mine foreman's or equivalent mine official's next regularly scheduled working shift. The record shall be kept at the mine for one year.

(d) Upon completion of construction of each seal a senior mine management official, such as a mine manager or superintendent, shall certify that the construction, installation, and materials used were in accordance with the approved ventilation plan. The mine operator shall retain the certification for as long as the seal is needed to serve the purpose for which it was built.

(e) The mine operator shall--

(1) Notify the District Manager between two and fourteen days prior to commencement of seal construction;

(2) Notify the District Manager, in writing, within five days of completion of a set of seals and provide a copy of the certification required in paragraph (d) of this section; and

(3) Submit a copy of quality control results to the District Manager for seal material properties specified by § 75.335 within 30 days of completion of quality control tests.

(f) Welding, cutting, and soldering. Welding, cutting, and soldering with an arc or flame are prohibited within 150 feet of a seal. An operator may request a different location in the ventilation plan to be approved by the District Manager. The operator's request must address methods the mine operator will use to continuously monitor atmospheric conditions in the sealed area during welding or burning; the airflow conditions in and around the work area; the rock dust and water application methods; the availability of fire extinguishers on hand; the procedures to maintain safe conditions, and other relevant factors.

(g) Sampling pipes.

(1) For seals constructed after April 18, 2008, one non-metallic sampling pipe shall be installed in each seal that shall extend into the center of the first connecting crosscut in by the seal. If an open crosscut does not exist, the sampling pipe shall extend one-half of the distance of the open entry in by the seal.

(2) Each sampling pipe shall be equipped with a shut-off valve and appropriate fittings for taking gas samples.

(3) The sampling pipes shall be labeled to indicate the location of the sampling point when more than one sampling pipe is installed through a seal.

(4) If a new seal is constructed to replace or reinforce an existing seal with a sampling pipe, the sampling pipe in the existing seal shall extend through the new seal. An additional sampling pipe shall be installed through each new seal to sample the area between seals, as specified in the approved ventilation plan.

(h) Water drainage system. For each set of seals constructed after April 18, 2008, the seal at the lowest elevation shall have a corrosion-resistant, non-metallic water drainage system. Seals shall not impound water or slurry. Water or slurry shall not accumulate within the sealed area to any depth that can adversely affect a seal.

30 CFR § 75.352

Actions in response to AMS malfunction, alert, or alarm signals.

(a) When a malfunction, alert, or alarm signal is received at the designated surface location, the sensor(s) that are activated must be identified and the AMS operator must promptly notify appropriate personnel.

(b) Upon notification of a malfunction, alert, or alarm signal, appropriate personnel must promptly initiate an investigation to determine the cause of the signal and take the required actions set forth in paragraphs (c), (d), or (e) of this section.

(c) If any sensor installed in accordance with § [75.340](#)(a)(1)(ii), [75.340](#)(a)(2)(ii), [75.350](#)(b), or [75.350](#)(d) indicates an alarm or if any two consecutive sensors indicate alert at the same time, the following procedures must be followed unless the cause of the signal(s) is known not to be a hazard to miners:

(1) Appropriate personnel must notify miners in affected working sections, in affected areas where mechanized mining equipment is being installed or removed, and

at other locations specified in the § [75.1502](#) approved mine emergency evacuation and firefighting program of instruction; and

(2) All personnel in the affected areas, unless assigned other duties under § [75.1502](#), must be withdrawn promptly to a safe location identified in the mine emergency evacuation and firefighting program of instruction.

(d) If there is an alert or alarm signal from a methane sensor installed in accordance with § [75.323](#)(d)(1)(ii) and [75.362](#)(f), an investigation must be initiated to determine the cause of the signal, and the actions required under § [75.323](#) must be taken.

(e) If any fire detection components of the AMS malfunction or are inoperative, immediate action must be taken to return the system to proper operation. While the AMS component repairs are being made, operation of the belt may continue if the following conditions are met:

(1) If one AMS sensor malfunctions or becomes inoperative, a trained person must continuously monitor for carbon monoxide or smoke at the inoperative sensor.

(2) If two or more adjacent AMS sensors malfunction or become inoperative, a trained person(s) must patrol and continuously monitor for carbon monoxide or smoke so that the affected areas will be traveled each hour in their entirety, or a trained person must be stationed to monitor at each inoperative sensor.

(3) If the complete AMS malfunctions or becomes inoperative, trained persons must patrol and continuously monitor for carbon monoxide or smoke so that the affected areas will be traveled each hour in their entirety.

(4) The trained person(s) monitoring under this section must, at a minimum, have two-way voice communication capabilities with the AMS operator at intervals not to exceed 2,000 feet and report contaminant levels to the AMS operator at intervals not to exceed 60 minutes.

(5) The trained person(s) monitoring under this section must report immediately to the AMS operator any concentration of the contaminant that reaches either the alert or alarm level specified in § [75.351](#)(i), or the alternate alert and alarm levels specified in paragraph (e)(7) of this section, unless the source of the contaminant is known not to present a hazard.

(6) Detectors used to monitor under this section must have a level of detectability equal to that required of the sensors in § [75.351](#)(l).

(7) For those AMSs using sensors other than carbon monoxide sensors, an alternate detector and the alert and alarm levels associated with that detector must be specified in the approved mine ventilation plan.

(f) If the minimum air velocity is not maintained when required under Sec. [75.350](#)(b)(7), immediate action must be taken to return the ventilation system to proper operation. While the ventilation system is being corrected, operation of the belt may continue only while a trained person(s) patrols and continuously monitors for

carbon monoxide or smoke as set forth in Sec. Sec. 75.352(e)(3) through (7), so that the affected areas will be traveled each hour in their entirety.

(g) The AMS shall automatically provide both a visual and audible signal in the belt entry at the point-feed regulator location, at affected sections, and at the designated surface location when carbon monoxide concentrations reach:

- (1) The alert level at both point-feed intake monitoring sensors; or
- (2) The alarm level at either point-feed intake monitoring sensor.

30 CFR § 75.360

Preshift examination.

(a)(1) Except as provided in paragraph (a)(2) of this section, a certified person designated by the operator must make a preshift examination within 3 hours preceding the beginning of any 8-hour interval during which any person is scheduled to work or travel underground. No person other than certified examiners may enter or remain in any underground area unless a preshift examination has been completed for the established 8-hour interval. The operator must establish 8-hour intervals of time subject to the required preshift examinations.

(2) Preshift examinations of areas where pumpers are scheduled to work or travel shall not be required prior to the pumper entering the areas if the pumper is a certified person and the pumper conducts an examination for hazardous conditions and violations of the mandatory health or safety standards referenced in paragraph (b)(11) of this section, tests for methane and oxygen deficiency, and determines if the air is moving in its proper direction in the area where the pumper works or travels. The examination of the area must be completed before the pumper performs any other work. A record of all hazardous conditions and violations of the mandatory health or safety standards found by the pumper shall be made and retained in accordance with [§75.363](#) of this part.

(b) The person conducting the preshift examination shall examine for hazardous conditions and violations of the mandatory health or safety standards referenced in paragraph (b)(11) of this section, test for methane and oxygen deficiency, and determine if the air is moving in its proper direction at the following locations:

- (1) Roadways, travelways and track haulageways where persons are scheduled, prior to the beginning of the preshift examination, to work or travel during the oncoming shift.
- (2) Belt conveyors that will be used to transport persons during the oncoming shift and the entries in which these belt conveyors are located.
- (3) Working sections and areas where mechanized mining equipment is being installed or removed, if anyone is scheduled to work on the section or in the area during the oncoming shift. The scope of the examination shall include the working places, approaches to worked-out areas and ventilation controls on these sections and in these areas, and the examination shall include tests of the roof, face and rib conditions on

these sections and in these areas.

(4) Approaches to worked-out areas along intake air courses and at the entries used to carry air into worked-out areas if the intake air passing the approaches is used to ventilate working sections where anyone is scheduled to work during the oncoming shift. The examination of the approaches to the worked-out areas shall be made in the intake air course immediately inby and outby each entry used to carry air into the worked-out area. An examination of the entries used to carry air into the worked-out areas shall be conducted at a point immediately inby the intersection of each entry with the intake air course.

(5) Seals along intake air courses where intake air passes by a seal to ventilate working sections where anyone is scheduled to work during the oncoming shift.

(6)(i) Entries and rooms developed after November 15, 1992, and developed more than 2 crosscuts off an intake air course without permanent ventilation controls where intake air passes through or by these entries or rooms to reach a working section where anyone is scheduled to work during the oncoming shift; and,

(ii) Entries and rooms developed after November 15, 1992, and driven more than 20 feet off an intake air course without a crosscut and without permanent ventilation controls where intake air passes through or by these entries or rooms to reach a working section where anyone is scheduled to work during the oncoming shift.

(7) Areas where trolley wires or trolley feeder wires are to be or will remain energized during the oncoming shift.

(8) High spots along intake air courses where methane is likely to accumulate, if equipment will be operated in the area during the shift.

(9) Underground electrical installations referred to in [§75.340\(a\)](#), except those pumps listed in [§75.340\(b\)\(2\)](#) through (b)(6), and areas where compressors subject to [§75.344](#) are installed if the electrical installation or compressor is or will be energized during the shift.

(10) Other areas where work or travel during the oncoming shift is scheduled prior to the beginning of the preshift examination.

(11) Preshift examinations shall include examinations to identify violations of the standards listed below:

- (i) § § 75.202(a) and 75.220(a)(1) — roof control;
- (ii) § § 75.333(h) and 75.370(a)(1) — ventilation, methane;
- (iii) § § 75.400 and 75.403 — accumulations of combustibile materials and application of rock dust;
- (iv) § 75.1403 — other safeguards, limited to maintenance of travelways along belt conveyors, off track haulage roadways, and track haulage, track switches, and other components for haulage;
- (v) § 75.1722(a) — guarding moving machine parts; and
- (vi) § 75.1731(a) — maintenance of belt conveyor components.

(c) The person conducting the preshift examination shall determine the volume of air entering each of the following areas if anyone is scheduled to work in the areas during the oncoming shift:

(1) In the last open crosscut of each set of entries or rooms on each working section and areas where mechanized mining equipment is being installed or removed. The last open crosscut is the crosscut in the line of pillars containing the permanent stoppings that separate the intake air courses and the return air courses.

(2) On each longwall or shortwall in the intake entry or entries at the intake end of the longwall or shortwall face immediately outby the face and the velocity of air at each end of the face at the locations specified in the approved ventilation plan.

(3) At the intake end of any pillar line--

(i) If a single split of air is used, in the intake entry furthest from the return air course, immediately outby the first open crosscut outby the line of pillars being mined; or

(ii) If a split system is used, in the intake entries of each split immediately inby the split point.

(d) The person conducting the preshift examination shall check the refuge alternative for damage, the integrity of the tamper-evident seal and the mechanisms required to deploy the refuge alternative, and the ready availability of compressed oxygen and air.

(e) The district manager may require the operator to examine other areas of the mine or examine for other hazards and violations of other mandatory health or safety standards found during the preshift examination.

(f) *Certification.* At each working place examined, the person doing the preshift examination shall certify by initials, date, and the time, that the examination was made. In areas required to be examined outby a working section, the certified person shall certify by initials, date, and the time at enough locations to show that the entire area has been examined.

(g) *Recordkeeping.* A record of the results of each preshift examination, including a record of hazardous conditions and violations of the nine mandatory health or safety standards and their locations found by the examiner during each examination, and of the results and locations of air and methane measurements, shall be made on the surface before any persons, other than certified persons conducting examinations required by this subpart, enter any underground area of the mine. The results of methane tests shall be recorded as the percentage of methane measured by the examiner. The record shall be made by the certified person who made the examination or by a person designated by the operator. If the record is made by someone other than the examiner, the examiner shall verify the record by initials and date by or at the end of the shift for which the examination was made. A record shall also be made by a certified person of the action taken to correct hazardous conditions and violations of mandatory health or safety standards found during the preshift examination. All preshift and corrective action records shall be countersigned by the mine foreman or equivalent mine official by the end of the mine foreman's or equivalent mine official's next regularly scheduled working shift. The records required by this section shall be made in a secure book that is not susceptible to alteration or electronically in a

computer system so as to be secure and not susceptible to alteration.

(h) *Retention period.* Records shall be retained at a surface location at the mine for at least 1 year and shall be made available for inspection by authorized representatives of the Secretary and the representative of miners.

30 CFR § 75.361

Supplemental examination.

(a)(1) Except for certified persons conducting examinations required by this subpart, within 3 hours before anyone enters an area in which a preshift examination has not been made for that shift, a certified person shall examine the area for hazardous conditions and violations of the mandatory health or safety standards referenced in paragraph (a)(2) of this section, determine whether the air is traveling in its proper direction and at its normal volume, and test for methane and oxygen deficiency.

(2) Supplementalexaminations shall include examinations to identify violations of the standards listed below:

- (i) § § 75.202(a) and 75.220(a)(1) — roof control;
- (ii) § § 75.333(h) and 75.370(a)(1) — ventilation, methane;
- (iii) § § 75.400 and 75.403 — accumulations of combustible materials and application of rock dust;
- (iv) § 75.1403 — other safeguards, limited to maintenance of travelways along belt conveyors, off track haulage roadways, and track haulage, track switches, and other components for haulage;
- (v) § 75.1722(a) — guarding moving machine parts; and
- (vi) § 75.1731(a) — maintenance of belt conveyor components.

(b) *Certification.* At each working place examined, the person making the supplemental examination shall certify by initials, date, and the time, that the examination was made. In areas required to be examined outby a working section, the certified person shall certify by initials, date, and the time at enough locations to show that the entire area has been examined.

30 CFR § 75.362

On-shift examination.

(a)(1) At least once during each shift, or more often if necessary for safety, a certified person designated by the operator shall conduct an on-shift examination of each section where anyone is assigned to work during the shift and any area where mechanized mining equipment is being installed or removed during the shift. The certified person shall check for hazardous conditions and violations of the mandatory health or safety standards referenced in paragraph (a)(3) of this section, test for methane and oxygen deficiency, and determine if the air is moving in its proper direction.

(a)(2) A person designated by the operator shall conduct an examination to assure compliance with the respirable dust control parameters specified in the mine ventilation plan. In those instances when a shift change is accomplished without an

interruption in production on a section, the examination shall be made anytime within 1 hour of the shift change. In those instances when there is an interruption in production during the shift change, the examination shall be made before production begins on a section. Deficiencies in dust controls shall be corrected before production begins or resumes. The examination shall include air quantities and velocities, water pressures and flow rates, excessive leakage in the water delivery system, water spray numbers and orientations, section ventilation and control device placement, and any other dust suppression measures required by the ventilation plan. Measurements of the air velocity and quantity, water pressure and flow rates are not required if continuous monitoring of these controls is used and indicates that the dust controls are functioning properly.

(a)(3) On-shift examinations shall include examinations to identify violations of the standards listed below:

- (i) § § 75.202(a) and 75.220(a)(1) — roof control;
- (ii) § § 75.333(h) and 75.370(a)(1) — ventilation, methane;
- (iii) § § 75.400 and 75.403 — accumulations of combustible materials and application of rock dust;
- (iv) § 75.1403 — other safeguards, limited to maintenance of travelways along belt conveyors, off track haulage roadways, and track haulage, track switches, and other components for haulage;
- (v) § 75.1722(a) — guarding moving machine parts; and
- (vi) § 75.1731(a) — maintenance of belt conveyor components.

(b) During each shift that coal is produced, a certified person shall examine for hazardous conditions and violations of the mandatory health or safety standards referenced in paragraph (a)(3) of this section along each belt conveyor haulageway where a belt conveyor is operated. This examination may be conducted at the same time as the preshift examination of belt conveyors and belt conveyor haulageways, if the examination is conducted within 3 hours before the oncoming shift.

(c) Persons conducting the on-shift examination shall determine at the following locations:

(1) The volume of air in the last open crosscut of each set of entries or rooms on each section and areas where mechanized mining equipment is being installed or removed. The last open crosscut is the crosscut in the line of pillars containing the permanent stoppings that separate the intake air courses and the return air courses.

(2) The volume of air on a longwall or shortwall, including areas where longwall or shortwall equipment is being installed or removed, in the intake entry or entries at the intake end of the longwall or shortwall.

(3) The velocity of air at each end of the longwall or shortwall face at the locations specified in the approved ventilation plan.

(4) The volume of air at the intake end of any pillar line--

(i) Where a single split of air is used in the intake entry furthest from the return air course immediately outby the first open crosscut outby the line of pillars being mined;

or

(ii) Where a split system is used in the intake entries of each split immediately inby the split point.

(d)(1) A qualified person shall make tests for methane--

(i) At the start of each shift at each working place before electrically operated equipment is energized; and

(ii) Immediately before equipment is energized, taken into, or operated in a working place; and

(iii) At 20-minute intervals, or more often if required in the approved ventilation plan at specific locations, during the operation of equipment in the working place.

(2) These methane tests shall be made at the face from under permanent roof support, using extendable probes or other acceptable means. When longwall or shortwall mining systems are used, these methane tests shall be made at the shearer, the plow, or the cutting head. When mining has been stopped for more than 20 minutes, methane tests shall be conducted prior to the start up of equipment.

(3) As an alternative method of compliance with paragraph (d)(2) of this section during roof bolting, methane tests may be made by sweeping an area not less than 16 feet inby the last area of permanently supported roof, using a probe or other acceptable means. This method of testing is conditioned on meeting the following requirements:

(i) The roof bolting machine must be equipped with an integral automated temporary roof support (ATRS) system that meets the requirements of 30 CFR [75.209](#).

(ii) The roof bolting machine must have a permanently mounted, MSHA-approved methane monitor which meets the maintenance and calibration requirements of 30 CFR 75.342(a)(4), the warning signal requirements of 30 CFR [75.342\(b\)](#), and the automatic de-energization requirements of 30 CFR 75.342(c).

(iii) The methane monitor sensor must be mounted near the inby end and within 18 inches of the longitudinal center of the ATRS support, and positioned at least 12 inches from the roof when the ATRS is fully deployed.

(iv) Manual methane tests must be made at intervals not exceeding 20 minutes. The test may be made either from under permanent roof support or from the roof bolter's work position protected by the deployed ATRS.

(v) Once a methane test is made at the face, all subsequent methane tests in the same area of unsupported roof must also be made at the face, from under permanent roof support, using extendable probes or other acceptable means at intervals not exceeding 20 minutes.

(vi) The district manager may require that the ventilation plan include the minimum air quantity and the position and placement of ventilation controls to be maintained during roof bolting.

(e) If auxiliary fans and tubing are used, they shall be inspected frequently.

(f) During each shift that coal is produced and at intervals not exceeding 4 hours, tests for methane shall be made by a certified person or by an atmospheric monitoring system (AMS) in each return split of air from each working section between the last working place, or longwall or shortwall face, ventilated by that split of air and the junction of the return air split with another air split, seal, or worked-out area. If auxiliary fans and tubing are used, the tests shall be made at a location outby the auxiliary fan discharge.

(g) *Certification.* (1) The person conducting the on-shift examination in belt haulage entries shall certify by initials, date, and time that the examination was made. The certified person shall certify by initials, date, and the time at enough locations to show that the entire area has been examined.

(2) The certified person directing the on-shift examination to assure compliance with the respirable dust control parameters specified in the mine ventilation plan shall certify by initials, date, and time that the examination was made.

30 CFR § 75.363

Hazardous conditions; posting, correcting and recording.

(a) Any hazardous condition found by the mine foreman or equivalent mine official, assistant mine foreman or equivalent mine official, or other certified persons designated by the operator for the purposes of conducting examinations under this subpart D, shall be posted with a conspicuous danger sign where anyone entering the areas would pass. A hazardous condition shall be corrected immediately or the area shall remain posted until the hazardous condition is corrected. If the condition creates an imminent danger, everyone except those persons referred to in section 104(c) of the Act shall be withdrawn from the area affected to a safe area until the hazardous condition is corrected. Only persons designated by the operator to correct or evaluate the hazardous condition may enter the posted area. Any violation of a mandatory health or safety standard found during a preshift, supplemental, on-shift, or weekly examination shall be corrected.

(b) A record shall be made of any hazardous condition and any violation of the nine mandatory health or safety standards found by the mine examiner. This record shall be kept in a book maintained for this purpose on the surface at the mine. The record shall be made by the completion of the shift on which the hazardous condition or violation of the nine mandatory health or safety standards is found and shall include the nature and location of the hazardous condition or violation and the corrective action taken. This record shall not be required for shifts when no hazardous conditions or violations of the nine mandatory health or safety standards are found.

(c) The record shall be made by the certified person who conducted the examination or a person designated by the operator. If made by a person other than the certified person, the certified person shall verify the record by initials and date by or at the end of the shift for which the examination was made. Records shall be countersigned by the mine foreman or equivalent mine official by the end of the mine foreman's or equivalent

mine official's next regularly scheduled working shift. The record shall be made in a secure book that is not susceptible to alteration or electronically in a computer system so as to be secure and not susceptible to alteration.

(d) *Retention period.* Records shall be retained at a surface location at the mine for at least 1 year and shall be made available for inspection by authorized representatives of the Secretary and the representative of miners.

(e) *Review of citations and orders.* The mine operator shall review with mine examiners on a quarterly basis citations and orders issued in areas where preshift, supplemental, on-shift, and weekly examinations are required.

30 CFR § 75.364

Weekly examination.

(a) *Worked-out areas.* (1) At least every 7 days, a certified person shall examine unsealed worked-out areas where no pillars have been recovered by traveling to the area of deepest penetration; measuring methane and oxygen concentrations and air quantities and making tests to determine if the air is moving in the proper direction in the area. The locations of measurement points where tests and measurements will be performed shall be included in the mine ventilation plan and shall be adequate in number and location to assure ventilation and air quality in the area. Air quantity measurements shall also be made where the air enters and leaves the worked-out area. An alternative method of evaluating the ventilation of the area may be approved in the ventilation plan.

(2) At least every 7 days, a certified person shall evaluate the effectiveness of bleeder systems required by [§75.334](#) as follows:

(i) Measurements of methane and oxygen concentrations and air quantity and a test to determine if the air is moving in its proper direction shall be made where air enters the worked-out area.

(ii) Measurements of methane and oxygen concentrations and air quantity and a test to determine if the air is moving in the proper direction shall be made immediately before the air enters a return split of air.

(iii) At least one entry of each set of bleeder entries used as part of a bleeder system under [§75.334](#) shall be traveled in its entirety. Measurements of methane and oxygen concentrations and air quantities and a test to determine if the air is moving in the proper direction shall be made at the measurement point locations specified in the mine ventilation plan to determine the effectiveness of the bleeder system.

(iv) In lieu of the requirements of paragraphs (a)(2)(i) and (iii) of this section, an alternative method of evaluation may be specified in the ventilation plan provided the alternative method results in proper evaluation of the effectiveness of the bleeder system.

(b) *Hazardous conditions and violations of mandatory health or safety standards.* At least every 7 days, an examination for hazardous conditions and violations of the mandatory health or safety standards referenced in paragraph (b)(8) of this section shall be made by a certified person designated by the operator at the following locations:

- (1) In at least one entry of each intake air course, in its entirety, so that the entire air course is traveled.
 - (2) In at least one entry of each return air course, in its entirety, so that the entire air course is traveled.
 - (3) In each longwall or shortwall travelway in its entirety, so that the entire travelway is traveled.
 - (4) At each seal along return and bleeder air courses and at each seal along intake air courses not examined under [§75.360\(b\)\(5\)](#).
 - (5) In each escapeway so that the entire escapeway is traveled.
 - (6) On each working section not examined under [§75.360\(b\)\(3\)](#) during the previous 7 days.
 - (7) At each water pump not examined during a preshift examination conducted during the previous 7 days.
- (c) *Measurements and tests.* At least every 7 days, a certified person shall--
- (1) Determine the volume of air entering the main intakes and in each intake split;
 - (2) Determine the volume of air and test for methane in the last open crosscut in any pair or set of developing entries or rooms, in the return of each split of air immediately before it enters the main returns, and where the air leaves the main returns; and
 - (3) Test for methane in the return entry nearest each set of seals immediately after the air passes the seals.
- (d) Hazardous conditions shall be corrected immediately. If the condition creates an imminent danger, everyone except those persons referred to in §104(c) of the Act shall be withdrawn from the area affected to a safe area until the hazardous condition is corrected.
- (8) Weekly examinations shall include examinations to identify violations of the standards listed below:
- (i) § § 75.202(a) and 75.220(a)(1) — roof control;
 - (ii) § § 75.333(h) and 75.370(a)(1) — ventilation, methane;
 - (iii) § § 75.400 and 75.403 — accumulations of combustible materials and application of rock dust; and
 - (iv) § 75.1403 — maintenance of off track haulage roadways, and track haulage, track switches, and other components for haulage;
 - (v) § 75.1722(a) — guarding moving machine parts; and
 - (vi) § 75.1731(a) — maintenance of belt conveyor components.
- (d) Hazardous conditions shall be corrected immediately. If the condition creates an imminent danger, everyone except those persons referred to in section 104(c) of the Act shall be withdrawn from the area affected to a safe area until the hazardous

condition is corrected. Any violation of the nine mandatory health or safety standards found during a weekly examination shall be corrected.

(e) The weekly examination may be conducted at the same time as the preshift or on-shift examinations.

(f)(1) The weekly examination is not required during any 7 day period in which no one enters any underground area of the mine.

(2) Except for certified persons required to make examinations, no one shall enter any underground area of the mine if a weekly examination has not been completed within the previous 7 days.

(g) *Certification.* The person making the weekly examinations shall certify by initials, date, and the time that the examination was made. Certifications and times shall appear at enough locations to show that the entire area has been examined.

(h) *Recordkeeping.* At the completion of any shift during which a portion of a weekly examination is conducted, a record of the results of each weekly examination, including a record of hazardous conditions found during each examination and their locations, the corrective action taken, and the results and location of air and methane measurements, shall be made. The results of methane tests shall be recorded as the percentage of methane measured by the examiner. The record shall be made by the person making the examination or a person designated by the operator. If made by a person other than the examiner, the examiner shall verify the record by the initials and date by or at the end of the shift for which the examination was made. The record shall be countersigned by the mine foreman or equivalent mine official by the end of the mine foreman's or equivalent mine official's next regularly scheduled working shift. The records required by this section shall be made in a secure book that is not susceptible to alteration or electronically in a computer system so as to be secure and not susceptible to alteration.

(h) *Recordkeeping.* At the completion of any shift during which a portion of a weekly examination is conducted, a record of the results of each weekly examination, including a record of hazardous conditions and violations of the nine mandatory health or safety standards found during each examination and their locations, the corrective action taken, and the results and location of air and methane measurements, shall be made. The results of methane tests shall be recorded as the percentage of methane measured by the examiner. The record shall be made by the person making the examination or a person designated by the operator. If made by a person other than the examiner, the examiner shall verify the record by initials and date by or at the end of the shift for which the examination was made. The record shall be countersigned by the mine foreman or equivalent mine official by the end of the mine foreman's or equivalent mine official's next regularly scheduled working shift. The records required by this section shall be made in a secure book that is not susceptible to alteration or electronically in a computer system so as to be secure and not susceptible to alteration.

(i) *Retention period.* Records shall be retained at a surface location at the mine for at least 1 year and shall be made available for inspection by authorized representatives of the Secretary and the representative of miners.

30 CFR § 75.380

Escapeways; bituminous and lignite mines.

(a) Except in situations addressed in [§75.381](#), [§75.385](#) and [§75.386](#), at least two separate and distinct travelable passageways shall be designated as escapeways and shall meet the requirements of this section.

(b) (1) Escapeways shall be provided from each working section, and each area where mechanized mining equipment is being installed or removed, continuous to the surface escape drift opening or continuous to the escape shaft or slope facilities to the surface.

(2) During equipment installation, these escapeways shall begin at the projected location for the section loading point. During equipment removal, they shall begin at the location of the last loading point.

(c) The two separate and distinct escapeways required by this section shall not end at a common shaft, slope, or drift opening, except that multiple compartment shafts or slopes separated by walls constructed of noncombustible material may be used as separate and distinct passageways.

(d) Each escapeway shall be-- (1) Maintained in a safe condition to always assure passage of anyone, including disabled persons;

(2) Clearly marked to show the route and direction of travel to the surface;

(3) Maintained to at least a height of 5 feet from the mine floor to the mine roof, excluding the thickness of any roof support, except that the escapeways shall be maintained to at least the height of the coalbed, excluding the thickness of any roof support, where the coalbed is less than 5 feet. In areas of mines where escapeways pass through doors, the height may be less than 5 feet, provided that sufficient height is maintained to enable miners, including disabled persons, to escape quickly in an emergency. In areas of mines developed before November 16, 1992, where escapeways pass over or under overcasts or undercasts, the height may be less than 5 feet provided that sufficient height is maintained to enable miners, including disabled persons, to escape quickly in an emergency. When there is a need to determine whether sufficient height is provided, MSHA may require a stretcher test where 4 persons carry a miner through the area in question on a stretcher;

(4) Maintained at least 6 feet wide except--

(i) Where necessary supplemental roof support is installed, the escapeway shall not be less than 4 feet wide; or

(ii) Where the route of travel passes through doors or other permanent ventilation controls, the escapeway shall be at least 4 feet wide to enable miners to escape quickly in an emergency, or

(iii) Where the alternate escapeway passes through doors or other permanent ventilation controls or where supplemental roof support is required and sufficient width is maintained to enable miners, including disabled persons, to escape quickly in an emergency. When there is a need to determine whether sufficient width is provided, MSHA may require a stretcher test where 4 persons carry a miner through the area in question on a stretcher, or

(iv) Where mobile equipment near working sections, and other equipment essential to

the ongoing operation of longwall sections, is necessary during normal mining operations, such as material cars containing rock dust or roof control supplies, or is to be used for the evacuation of miners off the section in the event of an emergency. In any instance, escapeways shall be of sufficient width to enable miners, including disabled persons, to escape quickly in an emergency. When there is a need to determine whether sufficient width is provided, MSHA may require a stretcher test where 4 persons carry a miner through the area in question on a stretcher;

(5) Located to follow the most direct, safe and practical route to the nearest mine opening suitable for the safe evacuation of miners; and

(6) Provided with ladders, stairways, ramps, or similar facilities where the escapeways cross over obstructions.

(7) Provided with a continuous, durable directional lifeline or equivalent device that shall be--

(i) Installed and maintained throughout the entire length of each escapeway as defined in paragraph (b)(1) of this section;

(ii) Flame-resistant in accordance with the requirements of part 18 of this chapter upon replacement of existing lifelines; but in no case later than June 15, 2009;

(iii) Marked with a reflective material every 25 feet;

(iv) Located in such a manner for miners to use effectively to escape;

(v) Equipped with one directional indicator cone securely attached to the lifeline, signifying the route of escape, placed at intervals not exceeding 100 feet. Cones shall be installed so that the tapered section points inby;

(vi) Equipped with one sphere securely attached to the lifeline at each intersection where personnel doors are installed in adjacent crosscuts;

(vii) Equipped with two securely attached cones, installed consecutively with the tapered section pointing inby, to signify an attached branch line is immediately ahead. (A) A branch line leading from the lifeline to an SCSR cache will be marked with four cones with the base sections in contact to form two diamond shapes. The cones must be placed within reach of the lifeline. (B) A branch line leading from the lifeline to a refuge alternative will be marked with a rigid spiraled coil at least eight inches in length. The spiraled coil must be placed within reach of the lifeline (see Illustration 1 below).

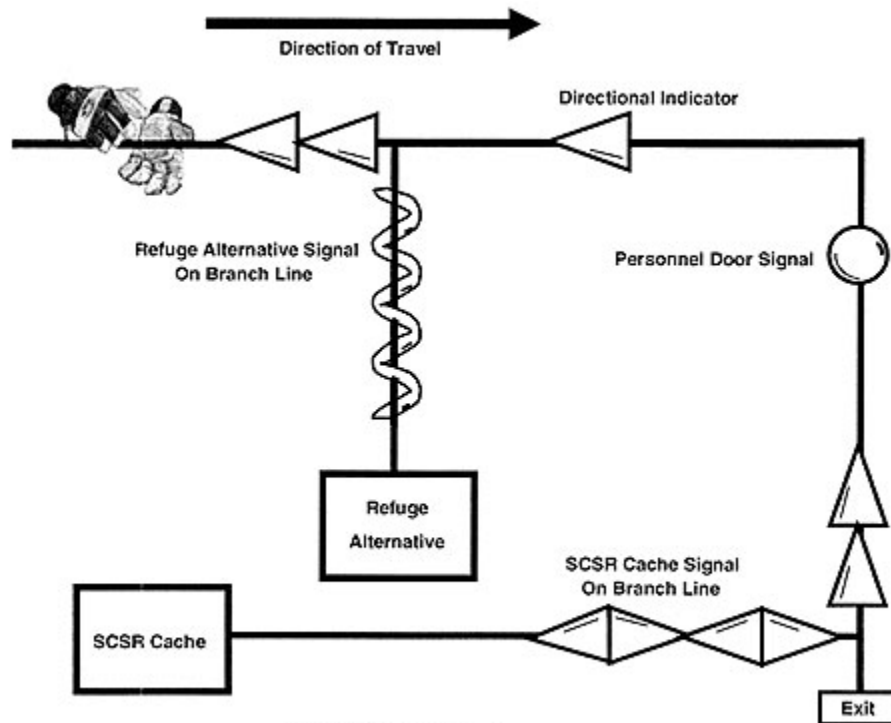

Illustration 1

(e) Surface openings shall be adequately protected to prevent surface fires, fumes, smoke, and flood water from entering the mine.

(f) *Primary escapeway.* (1) One escapeway that is ventilated with intake air shall be designated as the primary escapeway. The primary escapeway shall have a higher ventilation pressure than the belt entry unless the mine operator submits an alternative in the mine ventilation plan to protect the integrity of the primary escapeway, based on mine specific conditions, which is approved by the district manager.

(2) Paragraphs (f)(3) through (f)(7) of this section apply as follows:

- (i) To all areas of a primary escapeway developed on or after November 16, 1992;
- (ii) Effective as of June 10, 1997, to all areas of a primary escapeway developed between March 30, 1970 and November 16, 1992; and
- (iii) Effective as of March 11, 1997, to all areas of the primary escapeway developed prior to March 30, 1970 where separation of the belt and trolley haulage entries from the primary escapeway existed prior to November 16, 1992.

(3) The following equipment is not permitted in the primary escapeway:

- (i) Mobile equipment hauling coal except for hauling coal incidental to cleanup or maintenance of the primary escapeway.
- (ii) Compressors, except--
 - (A) Compressors necessary to maintain the escapeway in safe, travelable condition;
 - (B) Compressors that are components of equipment such as locomotives and rock dusting machines; and
 - (C) Compressors of less than five horsepower.
- (iii) Underground transformer stations, battery charging stations, substations, and

rectifiers except--

(A) Where necessary to maintain the escapeway in safe, travelable condition; and
(B) Battery charging stations and rectifiers and power centers with transformers that are either dry-type or contain nonflammable liquid, provided they are located on or near a working section and are moved as the section advances or retreats.

(iv) Water pumps, except--

(A) Water pumps necessary to maintain the escapeway in safe, travelable condition;
(B) Submersible pumps;
(C) Permissible pumps and associated permissible switchgear;
(D) Pumps located on or near a working section that are moved as the section advances or retreats;
(E) Pumps installed in anthracite mines; and
(F) Small portable pumps.

(4) Mobile equipment operated in the primary escapeway, except for continuous miners and as provided in paragraphs (f)(5), (f)(6), and (f)(7) of this section, shall be equipped with a fire suppression system installed according to § [75.1107-3](#) through 75.1107-16 that is--

(i) Manually operated and attended continuously by a person trained in the systems function and use, or
(ii) A multipurpose dry chemical type capable of both automatic and manual activation.

(5) Personnel carriers and small mobile equipment designed and used only for carrying people and small hand tools may be operated in primary escapeways if--

(i) The equipment is provided with a multipurpose dry chemical type fire suppression system capable of both automatic and manual activation, and the suppression system is suitable for the intended application and is listed or approved by a nationally recognized independent testing laboratory, or,

(ii) Battery powered and provided with two 10 pound multipurpose dry chemical portable fire extinguishers.

(6) Notwithstanding the requirements of paragraph (f)(3)(i), mobile equipment not provided with a fire suppression system may operate in the primary escapeway if no one is in by except those persons directly engaged in using or moving the equipment.

(7) Notwithstanding the requirements of paragraph (f)(3)(i), mobile equipment designated and used only as emergency vehicles or ambulances, may be operated in the primary escapeway without fire suppression systems.

(g) Except where separation of belt and trolley haulage entries from designated escapeways did not exist before November 15, 1992, and except as provided in § [75.350](#)(c), the primary escapeway must be separated from belt and trolley haulage entries for its entire length, to and including the first connecting crosscut outby each loading point except when a greater or lesser distance for this separation is specified and approved in the mine ventilation plan and does not pose a hazard to miners.

(h) *Alternate escapeway.* One escapeway shall be designated as the alternate escapeway. The alternate escapeway shall be separated from the primary escapeway for its entire length, except that the alternate and primary escapeways may be

ventilated from a common intake air shaft or slope opening.

(i) Mechanical escape facilities shall be provided and maintained for--

(1) Each shaft that is part of a designated escapeway and is greater than 50 feet in depth; and

(2) Each slope from the coal seam to the surface that is part of a designated escapeway and is inclined more than 9 degrees from the horizontal.

(j) Within 30 minutes after mine personnel on the surface have been notified of an emergency requiring evacuation, mechanical escape facilities provided under paragraph

(i) of this section shall be operational at the bottom of shaft and slope openings that are part of escapeways.

(k) Except where automatically activated hoisting equipment is used, the bottom of each shaft or slope opening that is part of a designated escapeway shall be equipped with a means of signaling a surface location where a person is always on duty when anyone is underground. When the signal is activated or the evacuation of persons underground is necessary, the person shall assure that mechanical escape facilities are operational as required by paragraph (j) of this section.

(l)(1) Stairways or mechanical escape facilities shall be installed in shafts that are part of the designated escapeways and that are 50 feet or less in depth, except ladders may be used in shafts that are part of the designated escapeways and that are 5 feet or less in depth.

(2) Stairways shall be constructed of concrete or metal, set on an angle not to exceed 45 degrees from the horizontal, and equipped on the open side with handrails. In addition, landing platforms that are at least 2 feet by 4 feet shall be installed at intervals not to exceed 20 vertical feet on the stairways and equipped on the open side with handrails.

(3) Ladders shall be constructed of metal, anchored securely, and set on an angle not to exceed 60 degrees from the horizontal.

(m) A travelway designed to prevent slippage shall be provided in slope and drift openings that are part of designated escapeways, unless mechanical escape facilities are installed.

30 CFR § 75.384

Longwall and shortwall travelways.

(a) If longwall or shortwall mining systems are used and the two designated escapeways required by [§75.380](#) are located on the headgate side of the longwall or shortwall, a travelway shall be provided on the tailgate side of that longwall or shortwall. The travelway shall be located to follow the most direct and safe practical route to a designated escapeway.

(b) The route of travel shall be clearly marked.

(c) When a roof fall or other blockage occurs that prevents travel in the travelway--

(1) Work shall cease on the longwall or shortwall face;

(2) Miners shall be withdrawn from face areas to a safe area outby the section loading point; and

(3) MSHA shall be notified.

(d) Work may resume on the longwall or shortwall face after the procedures set out in [§§75.215](#) and [75.222](#) are implemented.

30 CFR § 75.388

Boreholes in advance of mining.

(a) Boreholes shall be drilled in each advancing working place when the working place approaches--

(1) To within 50 feet of any area located in the mine as shown by surveys that are certified by a registered engineer or registered surveyor unless the area has been preshift examined;

(2) To within 200 feet of any area located in the mine not shown by surveys that are certified by a registered engineer or registered surveyor unless the area has been preshift examined; or

(3) To within 200 feet of any mine workings of an adjacent mine located in the same coalbed unless the mine workings have been preshift examined.

(b) Boreholes shall be drilled as follows:

(1) Into the working face, parallel to the rib, and within 3 feet of each rib.

(2) Into the working face, parallel to the rib, and at intervals across the face not to exceed 8 feet.

(3) At least 20 feet in depth in advance of the working face, and always maintained to a distance of 10 feet in advance of the working face.

(c) Boreholes shall be drilled in both ribs of advancing working places described in paragraph (a) of this section unless an alternative drilling plan is approved by the District Manager in accordance with paragraph (g) of this section. These boreholes shall be drilled--

(1) At an angle of 45 degrees to the direction of advance;

(2) At least 20 feet in depth; and

(3) At intervals not to exceed 8 feet.

(d) When a borehole penetrates an area that cannot be examined, and before mining continues, a certified person shall, if possible, determine--

- (1) The direction of airflow in the borehole;
- (2) The pressure differential between the penetrated area and the mine workings;
- (3) The concentrations of methane, oxygen, carbon monoxide, and carbon dioxide; and
- (4) Whether water is impounded within the penetrated area.

(e) Unless action is taken to dewater or to ventilate penetrated areas, boreholes shall be plugged with wooden plugs or similar devices when--

(1) Tests conducted at the boreholes show that the atmosphere in the penetrated area contains more than 1.0 percent methane, less than 19.5 percent oxygen, or harmful concentrations of carbon monoxide, carbon dioxide or other explosive, harmful or noxious gases;

(2) Tests for methane, oxygen, carbon monoxide, and carbon dioxide cannot be made because air from mine workings is flowing into the penetrated area; or

(3) Water is discharging through the boreholes from the penetrated area into the mine workings.

(f) If mining is to be conducted within 50 feet above or below an inaccessible area of another mine, boreholes shall be drilled, as necessary, according to a plan approved by the district manager.

(g) Alternative borehole patterns that provide the same protection to miners as the pattern established by paragraphs (b) and (c) of this section may be used under a plan approved by the district manager.

VENTILATION

Questions for Review

Q: How often shall bleeder entries be examined by a certified person designated by the operator?

A: CFR 75.364 (a)

Q: The area surrounding all main fans should be kept free of combustible material for what distance?

A: CFR 75.311 (f)

Q: The volume of air near the main return should be measured how often?

A: CFR 75.364 (c)

Q: When shall methane checks be made in face areas?

A: CFR 75.362

Q: When may changes be made in the main ventilating air current?

A: CFR 75.324

Q: Main fans shall be installed on the surface in fire-proof housings and connected to the mine opening with fire-proof air ducts. How far should the offset be between the main fan and the nearest side of the mine opening?

A: CFR 75.310

Q: What is the minimum, allowable amount of air passing through the last open crosscut in a section?

A: CFR 75.325

Q: What is the minimum air velocity allowed in working systems not using a blowing system?

A: CFR 75.326

Q: When long wall mining is practiced, where should the volume of air be measured?

A: CFR 75.362

Q: What is the minimum oxygen content permitted in air where men work or travel underground?

A: CFR 75.321

Q: When shall main ventilating fans be inspected at mines?

A: CFR 75.312

Q: What are the CFR requirements for the records of daily fan inspections and the fan pressure recording gage charts?

A: CFR 75.312

Q: How is the perimeter of an airway found?

A: See math formulas

Q: The quantity of air in the main return of a mine is 200,000 cfm and the methane content is 0.15%. How much methane is liberated in 24 hours?

A: See math formulas

Q: What is the minimum quantity of air required in each working face from which coal is being mined, cut or loaded?

A: CFR 75.325

Q: What is the maximum allowable percentage of methane in any bleeder entry immediately before the air in that split joins another split of air?

A: CFR 75.323

Q: What are the principal requirements of stoppings?
A: CFR 75.332

Q: How must seals be constructed?
A: CFR 75.337

Q: How much time do you have after a fan failure to de-energize the mine power and withdraw all person from the working faces?
A: CFR 75.313

Q: What instruments should be provided on all main mine fans?
A: CFR 75.310

Q: What is the most reliable means of producing ventilation in the entire mine?
A: CFR 75.302

Q: What is the rubbing surface of an entry 11.5 feet wide, 5.25 feet high and 4,000 feet long?
A: See math formulas

Q: How is the velocity of an air current found?
A: See math formulas

Q: If an airway is 12 feet wide and 6 feet high, what is the area?
A: See math formulas

Q: When ventilation tubing is used in conjunction with auxiliary fans, what should be done before the fans are shut off between shifts to prevent methane accumulation?
A: CFR 75.331

CHAPTER FOUR

ELECTRICITY

1. Electrical Accidents
2. High and Low Voltages
3. Electrical Symbols
4. Federal Mine Safety & Health Act of 1977
5. Code of Federal Regulation Part 75
6. Questions and Review

ELECTRICITY

ELECTRICAL ACCIDENTS



Electrical accidents are the 4th leading cause of death in mining and are disproportionately fatal compared with most other types of mining accidents. Electrical shock causes over 90% of all mine electrical fatalities. About one-fifth of these deaths result when high-reaching mobile equipment contacts power lines overhead. Burns are the leading cause of electrical injury by a nearly 2-to-1 margin. They typically result from non-contact electrical arc flashes which can produce temperatures as high as 35,000 degrees F. Pressure waves from the rapidly-heated air cause secondary injuries such as blunt-force trauma, cuts, abrasions, and hearing damage. One-half of all mine electrical injuries and fatalities occur during electrical maintenance work, with the following electrical components most commonly involved: circuit breakers, conductors, batteries, and meters. The wide variety of electrical injuries on-the-job suggests that no single intervention strategy can eliminate occupational electrical fatalities and injuries. Instead, multi-faceted research approaches that consider not only engineering controls but also organization of work, training, and personal protective equipment are needed to mitigate electrical hazards.

Information electrical accidents was obtained from the following publications/websites:

- **NIOSH Office of Mine Safety and Health Research**

ELECTRICITY

HIGH AND LOW VOLTAGES

The numerical definition of **high voltage** depends on the context of the discussion. Two factors considered in the classification of a "high voltage" are the possibility of causing a spark in air, and the danger of electric shock by contact or proximity. The definitions may refer either to the voltage between two conductors of a system, or between any conductor and ground.

"Low voltage" is characterized by carrying a substantial risk of electric shock, but only a minor risk of electric arcs through air.

IEC voltage range	AC	DC	defining risk
High voltage	Greater than 1000 V _{rms}	Greater than 1500 V	electrical arcing
Low voltage	50–1000 V _{rms}	120–1500 V	electrical shock
Extra-low voltage	Less than 50 V _{rms}	Less than 120 V	low risk

Safety



International safety symbol "Caution, risk of electric shock" (ISO 3864), colloquially known as **high voltage symbol**.

Voltages of greater than 50 V applied across dry unbroken human skin are capable of producing heart fibrillation if they produce electric currents in body tissues which happen to pass through the chest area. The electrocution danger is mostly determined by the low electrical conductivity of dry human skin. If skin is wet, or if there are wounds, or if the voltage is applied to electrodes which penetrate the skin, then even voltage sources below 40 V can be lethal if contacted.

Accidental contact with high voltage supplying sufficient energy will usually result in severe injury or death. This can occur as a person's body provides a path for current flow causing tissue damage and heart failure. Other injuries can include burns from the arc

generated by the accidental contact. These can be especially dangerous if the victim's airways are affected. Injuries may also be suffered as a result of the physical forces exerted as people may fall from height or be thrown a considerable distance.

Low-energy exposure to high voltage may be harmless, such as the spark produced in a dry climate when touching a doorknob after walking across a carpeted floor.

Toxic gases

Electrical discharges, including partial discharge and corona, can produce small quantities of toxic gases, which in a confined space can be a serious health hazard. These gases include ozone and various oxides of nitrogen.

Basic Analog Electronic Symbols

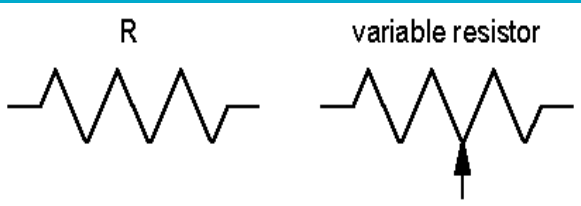
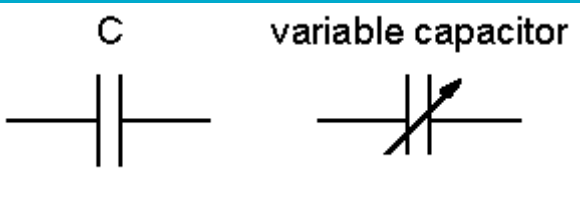
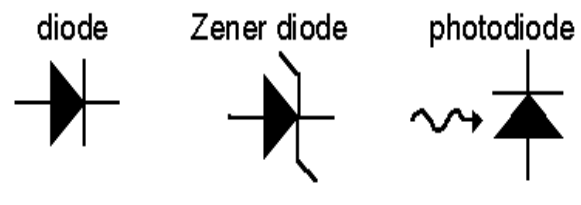
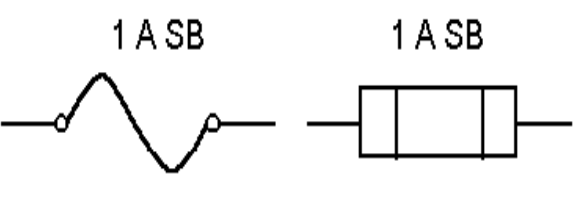
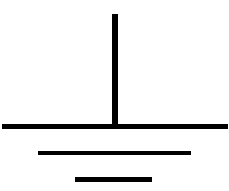
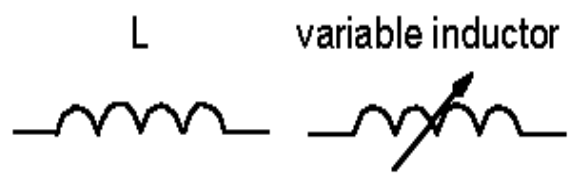
Electronic Symbols	
<p>R variable resistor</p> 	<p>C variable capacitor</p> 
Resistors	Capacitors
<p>diode Zener diode photodiode</p> 	<p>1 A SB 1 A SB</p> 
Diodes	Fuses
	<p>L variable inductor</p> 
Ground or GND	Inductor or Coil

Electronic Symbols



Lamp

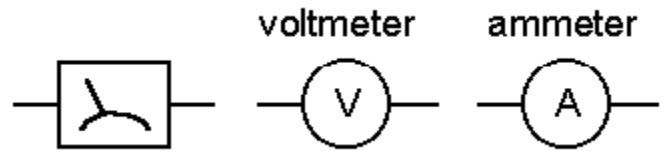

Meters

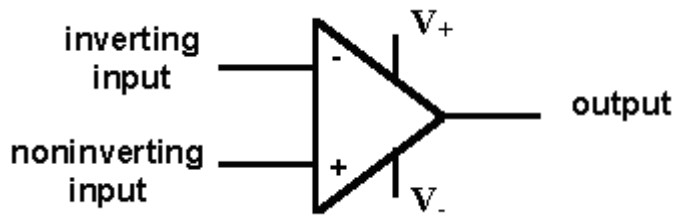

Operational Amplifier or Op-Amp

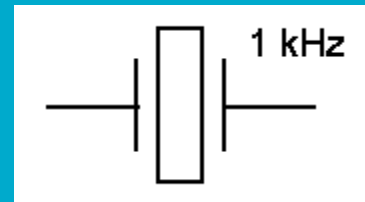

Oscillator Crystal

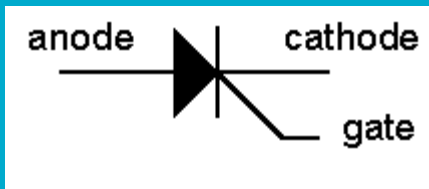

Silicon Controlled Rectifier or SCR

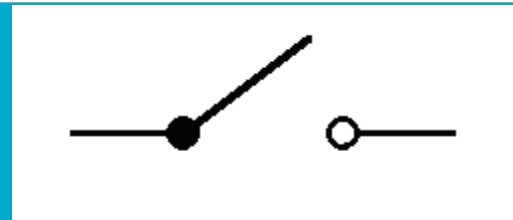

Switch

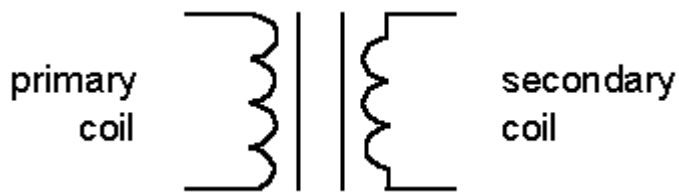

Iron Core Transformer

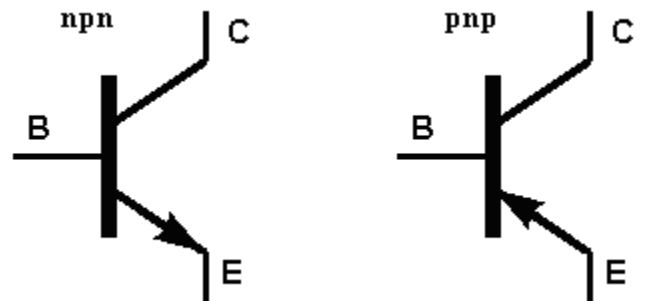

Bi-Polar Transistors

**Federal Mine Safety & Health Act of 1977,
Public Law 91-173,
as amended by Public Law 95-164***

**TITLE III - INTERIM
MANDATORY SAFETY STANDARDS
FOR UNDERGROUND COAL MINES**

ELECTRICAL EQUIPMENT GENERAL

SEC. 305. (a)(1) Effective one year after the operative date of this title--

- (A) all junction or distribution boxes used for making multiple power connections in by the last open crosscut shall be permissible;
- (B) all handheld electric drills, blower and exhaust fans, electric pumps, and such other low horsepower electric face equipment as the Secretary may designate within two months after the operative date of this title which are taken into or used in by the last open crosscut of any coal mine shall be permissible;
- (C) all electric face equipment which is taken into or used in by the last open crosscut of any coal mine classified under any provision of law as gassy prior to the operative date of this title shall be permissible; and
- (D) all other electric face equipment which is taken into or used in by the last crosscut of any coal mine, except a coal mine referred to in paragraph (2) of this subsection, which has not been classified under any provision of law as a gassy mine prior to the operative date of this title shall be permissible;

(2) Effective four years after the operative date of this title, all electric face equipment, other than equipment referred to in paragraph (1)(B) of this subsection, which is taken into or used in by the last open crosscut of any coal mine which is operated entirely in coal seams located above the watertable and which has not been classified under any provision of law as a gassy mine prior to the operative date of this title and in which one or more openings were made prior to the date of enactment of this Act, shall be permissible, except that any operator of such mine who is unable to comply with the provisions of this paragraph on such effective date may file with the Panel an application for a permit for noncompliance ninety days prior to such date. If the Panel determines, after notice to all interested persons and an opportunity for a public hearing under section 5 of this Act, that such application satisfies the provisions of paragraph (10) of this subsection and that such operator, despite his diligent efforts, will be unable to comply with such provisions, the Panel may issue to such operator such a permit. Such permit shall entitle the permittee to an additional extension of time to comply with the provisions of this paragraph of not to exceed twenty-four months, as determined by the Panel, from such effective date.

(3) The operator of each coal mine shall maintain in permissible condition all electric face equipment required by this subsection to be permissible which is taken into or used in by the last open crosscut of any such mine.

(4) Each operator of a coal mine shall, within two months after the operative date of this title, file with the Secretary a statement listing all electric face equipment by type and manufacturer being used by such operator in connection with mining operations in such mine as of the date of such filing, and stating whether such equipment is permissible and maintained in permissible condition or is nonpermissible on such date of filing, and, if nonpermissible, whether such nonpermissible equipment has ever been rated as permissible, and such other information as the Secretary may require.

(5) The Secretary shall promptly conduct a survey as to the total availability of new or rebuilt permissible electric face equipment and replacement parts for such equipment and, within six months after the operative date of this title, publish the results of such survey.

(6) Any operator of a coal mine who is unable to comply with the provisions of paragraph (1)(D) of this subsection within one year after the operative date of this title may file with the Panel an application for a permit for noncompliance. If the Panel determines that such application satisfies the provisions of paragraph (10) of this subsection, the Panel shall issue to such operator a permit for noncompliance. Such permit shall entitle the permittee to an extension of time to comply with such provisions of paragraph (1)(D) of not to exceed twelve months, as determined by the Panel, from the date that compliance with the provisions of paragraph (1)(D) of this subsection is required.

(7) Any operator of a coal mine issued a permit under paragraph (6) of this subsection who, ninety days prior to the termination of such permit, or renewal thereof, determines that he will be unable to comply with the provisions of paragraph (1)(D) of this subsection upon the expiration of such permit may file with the Panel an application for renewal thereof. Upon receipt of such application, the Panel, if it determines, after notice to all interested persons and an opportunity for a public hearing under section 5 of this Act, that such application satisfies the provisions of paragraph (10) of this subsection and that such operator, despite his diligent efforts, will be unable to comply with the provisions of paragraph (1)(D), may renew the permit for a period not exceeding twelve months.

(8) Any permit or renewal thereof issued pursuant to this subsection shall entitle the permittee to use such nonpermissible electric face equipment specified in the permit during the term of such permit.

(9) Permits for noncompliance issued under paragraphs (6) or (7) of this subsection shall, in the aggregate, not extend the period of noncompliance more than forty-eight months after the date of enactment of this Act.

(10) Any application for a permit of noncompliance filed under this subsection shall contain a statement by the operator--

(A) that he is unable to comply with paragraph (1)(D) or paragraph (2) of this subsection, as appropriate, within the time prescribed;

(B) listing the nonpermissible electric face equipment being used by such operator in connection with mining operations in such mine on the operative date of this title and the date of the application by type and manufacturer for which a noncompliance permit is requested and whether such equipment had ever been rated as permissible;

(C) setting forth the actions taken from and after the operative date of this title to comply with paragraph (1)(D) or paragraph (2) of this subsection, as appropriate, together with a plan setting forth a schedule of compliance with said paragraphs for each such equipment referred to in such paragraphs and being used by the operator in connection with mining operations in such mine with respect to which such permit is requested and the means and measures to be employed to achieve compliance; and

(D) including such other information as the Panel may require.

(11) No permit for noncompliance shall be issued under this subsection for any nonpermissible electric face equipment, unless such equipment was being used by an operator in connection with the mining operations in a coal mine on the operative date of this title.

(12) Effective one year after the operative date of this title, all replacement equipment acquired for use in any mine referred to in this subsection shall be permissible and shall be maintained in a permissible condition, and in the event of any major overhaul of any item of equipment in use one year from the operative date of this title such equipment shall be put in, and thereafter maintained in, a permissible condition, unless, in the opinion of the Secretary, such equipment or necessary replacement parts are not available.

(b) A copy of any permit granted under this section shall be mailed immediately to a representative of the miners of the mine to which it pertains, and to the public official or agency of the State charged with administering State laws relating to coal mine health and safety in such mine.

(c) Any coal mine which, prior to the operative date of this title, was classed gassy under any provision of law and was required to use permissible electric face equipment and to maintain such equipment in a permissible condition shall continue to use such equipment and to maintain such equipment in such condition.

(d) All power-connection points, except where permissible power connection units are used, outby the last open crosscut shall be in intake air.

(e) The location and the electrical rating of all stationary electric apparatus in connection with the mine electric system, including permanent cables, switchgear, rectifying substations, transformers, permanent pumps and trolley wires and trolley

feeder wires, and settings of all direct-current circuit breakers protecting underground trolley circuits, shall be shown on a mine map. Any changes made in a location, electric rating, or setting shall be promptly shown on the map when the change is made. Such map shall be available to an authorized representative of the Secretary and to the miners in such mine.

(f) All power circuits and electric equipment shall be deenergized before work is done on such circuits and equipment, except when necessary for trouble shooting or testing. In addition, energized trolley wires may be repaired only by a person trained to perform electrical work and to maintain electrical equipment and the operator of such mine shall require that such person wear approved and tested insulated shoes and wireman's gloves. No electrical work shall be performed on low-, medium-, or high-voltage distribution circuits or equipment, except by a qualified person or by a person trained to perform electrical work and to maintain electrical equipment under the direct supervision of a qualified person. Disconnecting devices shall be locked out and suitably tagged by the persons who performed such work, except that, in cases where locking out is not possible, such devices shall be opened and suitably tagged by such persons. Locks or tags shall be removed only by the persons who installed them or, if such persons are unavailable, by persons authorized by the operator or his agent.

(g) All electric equipment shall be frequently examined, tested, and properly maintained by a qualified person to assure safe operating conditions. When a potentially dangerous condition is found on electric equipment, such equipment shall be removed from service until such condition is corrected. A record of such examinations shall be kept and made available to an authorized representative of the Secretary and to the miners in such mine.

(h) All electric conductors shall be sufficient in size and have adequate current-carrying capacity and be of such construction that a rise in temperature resulting from normal operation will not damage the insulating materials.

(i) All electrical connections or splices in conductors shall be mechanically and electrically efficient, and suitable connectors shall be used. All electrical connections or splices in insulated wire shall be reinsulated at least to the same degree of protection as the remainder of the wire.

(j) Cables shall enter metal frames of motors, splice boxes, and electric compartments only through proper fittings. When insulated wires other than cables pass through metal frames the holes shall be substantially bushed with insulated bushings.

(k) All power wires(except trailing cables on mobile equipment, specially designed cables conducting high-voltage power to underground rectifying equipment or transformers, or bare or insulated ground and return wires) shall be supported on well-insulated insulators and shall not contact combustible material, roof, or ribs.

(l) Power wires and cables, except trolley wires, trolley feeder wires, and bare signal wires, shall be insulated adequately and fully protected.

(m) Automatic circuit-breaking devices or fuses of the correct type and capacity shall be installed so as to protect all electric equipment and circuits against short circuit and overloads. Three-phase motors on all electric equipment shall be provided with overload protection that will deenergize all three phases in the event that any phase is overloaded.

(n) In all main power circuits, disconnecting switches shall be installed underground within five hundred feet of the bottoms of shafts and boreholes through which main power circuits enter the underground area of the mine and within five hundred feet of all other places where main power circuits enter the underground area of the mine.

(o) All electric equipment shall be provided with switches or other controls that are safely designed, constructed, and installed.

(p) Each ungrounded, exposed power conductor that leads underground shall be equipped with suitable lightning arresters of approved type within one hundred feet of the point where the circuit enters the mine. Lightning arresters shall be connected to a low resistance grounding medium on the surface which shall be separated from neutral grounds by a distance of not less than twenty-five feet.

(q) No device for the purpose of lighting any coal mine which has not been approved by the Secretary or his authorized representative shall be permitted in such mine.

(r) An authorized representative of the Secretary may require in any mine that electric face equipment be provided with devices that will permit the equipment to be deenergized quickly in the event of an emergency.

GROUNDING

SEC. 307. (a) All metallic sheaths, armors, and conduits enclosing power conductors shall be electrically continuous throughout and shall be grounded by methods approved by an authorized representative of the Secretary. Metallic frames, casings, and other enclosures of electric equipment that can become "alive" through failure of insulation or by contact with energized parts shall be grounded by methods approved by an authorized representative of the Secretary. Methods other than grounding which provide no less effective protection may be permitted by the Secretary or his authorized representative.

(b) The frames of all offtrack direct current machines and the enclosures of related detached components shall be effectively grounded, or otherwise maintained at no less safe voltages, by methods approved by an authorized representative of the Secretary.

(c) The frames of all stationary high-voltage equipment receiving power from ungrounded delta systems shall be grounded by methods approved by an authorized representative of the Secretary.

(d) High-voltage lines, both on the surface and underground, shall be deenergized and grounded before work is performed on them, except that repairs may be permitted, in the case of energized surface high-voltage lines, if such repairs are made by a qualified person in accordance with procedures and safeguards, including, but not limited to, a requirement that the operator of such mine provide, test, and maintain protective devices in making such repairs, to be prescribed by the Secretary prior to the operative date of this title.

(e) When not in use, power circuits underground shall be deenergized on idle days and idle shifts, except that rectifiers and transformers may remain energized.

UNDERGROUND HIGH-VOLTAGE DISTRIBUTION

SEC. 308. (a) High-voltage circuits entering the underground area of any coal mine shall be protected by suitable circuit breakers of adequate interrupting capacity which are properly tested and maintained as prescribed by the Secretary. Such breakers shall be equipped with devices to provide protection against under-voltage, grounded phase, short circuit, and overcurrent.

(b) High-voltage circuits extending underground and supplying portable, mobile, or stationary high-voltage equipment shall contain either a direct or derived neutral which shall be grounded through a suitable resistor at the source transformers, and a grounding circuit, originating at the grounded side of the grounding resistor, shall extend along with the power conductors and serve as a grounding conductor for the frames of all high-voltage equipment supplied power from that circuit, except that the Secretary or his authorized representative may permit ungrounded high-voltage circuits to be extended underground to feed stationary electrical equipment if such circuits are either steel armored or installed in grounded, rigid steel conduit throughout their entire length, and upon his finding that such exception does not pose a hazard to the miners. Within one hundred feet of the point on the surface where high-voltage circuits enter the underground portion of the mine, disconnecting devices shall be installed and so equipped or designed in such a manner that it can be determined by visual observation that the power is disconnected, except that the Secretary or his authorized representative may permit such devices to be installed at a greater distance from such area of the mine if he determines, based on existing physical conditions, that such installation will be more accessible at a greater distance and will not pose any hazard to the miners.

(c) The grounding resistor, where required, shall be of the proper ohmic value to limit the voltage drop in the grounding circuit external to the resistor to not more than 100 volts under fault conditions. The grounding resistor shall be rated for maximum fault current continuously and insulated from ground for a voltage equal to the phase-to-phase voltage of the system.

(d) Six months after the operative date of this title, high-voltage, resistance grounded systems shall include a fail safe ground check circuit to monitor continuously the grounding circuit to assure continuity and the fail safe ground check circuit shall cause the circuit breaker to open when either the ground or pilot check wire is broken, or other no less effective device approved by the Secretary or his authorized representative to assure such continuity, except that an extension of time, not in excess of twelve months, may be permitted by the Secretary on a mine-by-mine basis if he determines that such equipment is not available.

(e)(1) Underground high-voltage cables used in resistance grounded systems shall be equipped with metallic shields around each power conductor, with one or more ground conductors having a total cross-sectional area of not less than one-half the power conductor, and with an insulated internal or external conductor not smaller than No. 8 (AWG) for the ground continuity check circuit.

(2) All such cables shall be adequate for the intended current and voltage. Splices made in such cables shall provide continuity of all components.

(f) Couplers that are used with medium-voltage or high-voltage power circuits shall be of the three-phase type with a full metallic shell, except that the Secretary may permit, under such guidelines as he may prescribe, no less effective couplers constructed of materials other than metal. Couplers shall be adequate for the voltage and current expected. All exposed metal on the metallic couplers shall be grounded to the ground conductor in the cable. The coupler shall be constructed so that the ground check continuity conductor shall be broken first and the ground conductors shall be broken last when the coupler is being uncoupled.

(g) Single-phase loads, such as transformer primaries, shall be connected phase to phase.

(h) All underground high-voltage transmission cables shall be installed only in regularly inspected aircourses and haulageways, and shall be covered, buried, or placed so as to afford protection against damage, guarded where men regularly work or pass under them unless they are six and one-half feet or more above the floor or rail, securely anchored, properly insulated, and guarded at ends, and covered, insulated, or placed to prevent contact with trolley wires and other low-voltage circuits.

(i) Disconnecting devices shall be installed at the beginning of branch lines in high-voltage circuits and equipped or designed in such a manner that it can be determined by visual observation that the circuit is deenergized when the switches are open.

(j) Circuit breakers and disconnecting switches underground shall be marked for identification.

(k) In the case of high-voltage cables used as trailing cables, temporary splices shall not be used and all permanent splices shall be made in accordance with section

306(e) of this title. Terminations and splices in all other high-voltage cables shall be made in accordance with the manufacturer's specifications.

(l) Frames, supporting structures, and enclosures of stationary, portable, or mobile underground high-voltage equipment and all high-voltage equipment supplying power to such equipment receiving power from resistance grounded systems shall be effectively grounded to the high-voltage ground.

(m) Power centers and portable transformers shall be deenergized before they are moved from one location to another, except that, when equipment powered by sources other than such centers or transformers is not available, the Secretary may permit such centers and transformers to be moved while energized, if he determines that another equivalent or greater hazard may otherwise be created, and if they are moved under the supervision of a qualified person, and if such centers and transformers are examined prior to such movement by such person and found to be grounded by methods approved by an authorized representative of the Secretary and otherwise protected from hazards to the miner. A record shall be kept of such examinations. High-voltage cables, other than trailing cables, shall not be moved or handled at any time while energized, except that, when such centers and transformers are moved while energized as permitted under this subsection, energized high-voltage cables attached to such centers and transformers may be moved only by a qualified person and the operator of such mine shall require that such person wear approved and tested insulated wireman's gloves.

UNDERGROUND LOW- AND MEDIUM-VOLTAGE ALTERNATING CURRENT CIRCUITS

SEC. 309. (a) Low- and medium-voltage power circuits serving three-phase alternating current equipment shall be protected by suitable circuit breakers of adequate interrupting capacity which are properly tested and maintained as prescribed by the Secretary. Such breakers shall be equipped with devices to provide protection against under-voltage, grounded phase, short circuit, and over-current.

(b) Low- and medium-voltage three-phase alternating-current circuits used underground shall contain either a direct or derived neutral which shall be grounded through a suitable resistor at the power center, and a grounding circuit, originating at the grounded side of the grounding resistor, shall extend along with the power conductors and serve as a grounding conductor for the frames of all the electrical equipment supplied power from that circuit, except that the Secretary or his authorized representative may permit ungrounded low- and medium-voltage circuits to be used underground to feed such stationary electrical equipment if such circuits are either steel armored or installed in grounded rigid steel conduit throughout their entire length. The grounding resistor, where required, shall be of the proper ohmic value to limit the ground fault current to 25 amperes. The grounding resistor shall be rated for maximum fault current continuously and insulated from ground for a voltage equal to the phase-to-phase voltage of the system.

(c) Six months after the operative date of this title, low-and medium-voltage resistance grounded systems shall include a fail safe ground check circuit to monitor continuously the grounding circuit to assure continuity which ground check circuit shall cause the circuit breaker to open when either the ground or pilot check wire is broken, or other no less effective device approved by the Secretary or his authorized representative to assure such continuity, except that an extension of time, not in excess of twelve months, may be permitted by the Secretary on a mine-by-mine basis if he determines that such equipment is not available. Cable couplers shall be constructed so that the ground check continuity conductor shall be broken first and the ground conductors shall be broken last when the coupler is being uncoupled.

(d) Disconnecting devices shall be installed in conjunction with the circuit breaker to provide visual evidence that the power is disconnected. Trailing cables for mobile equipment shall contain one or more ground conductors having a cross sectional area of not less than one-half the power conductor, and, six months after the operative date of this title, an insulated conductor for the ground continuity check circuit or other no less effective device approved by the Secretary or his authorized representative to assure such continuity, except that an extension of time, not in excess of twelve months may be permitted by the Secretary on a mine-by-mine basis if he determines that such equipment is not available. Splices made in the cables shall provide continuity of all components.

(e) Single phase loads shall be connected phase to phase.

(f) Circuit breakers shall be marked for identification.

(g) Trailing cables for medium voltage circuits shall include grounding conductors, a ground check conductor, and ground metallic shields around each power conductor or a grounded metallic shield over the assembly, except that on equipment employing cable reels, cables without shields may be used if the insulation is rated 2,000 volts or more.



Title 30

Code of Federal Regulation

30 CFR § 75.2

Definitions.

The following definitions apply in this part.

Act. The Federal Mine Safety and Health Act of 1977.

Active workings. Any place in a coal mine where miners are normally required to work or travel.

Adequate interrupting capacity. The ability of an electrical protective device, based upon its required and intended application, to safely interrupt values of current in excess of its trip setting or melting point.

Anthracite. Coals with a volatile ratio equal to 0.12 or less. The volatile ratio is the volatile matter content divided by the volatile matter plus the fixed carbon.

Approval documentation. Formal papers issued by the Mine Safety and Health Administration which describe and illustrate the complete assembly of electrical machinery or accessories which have met the applicable requirements of 30 CFR part 18.

Certified or registered. As applied to any person, a person certified or registered by the State in which the coal mine is located to perform duties prescribed by this part 75, except that in a State where no program of certification or registration is provided or where the program does not meet at least minimum Federal standards established by the Secretary, such certification or registration shall be by the Secretary.

Circuit-interrupting device. A device designed to open and close a circuit by nonautomatic means and to open the circuit automatically at a predetermined overcurrent value without damage to the device when operated within its rating.

Coal mine. Includes areas of adjoining mines connected underground.

Filter Self-Rescuer (FSR). A type of gas mask approved by MSHA and NIOSH under 42 CFR part 84 for escape only from underground mines and which provides at least 1 hour of protection against carbon monoxide.

Ground fault or grounded phase. An unintentional connection between an electric circuit and the grounding system.

Low voltage. Up to and including 660 volts, medium voltage means voltages from 661 to 1,000 volts; and high voltage means more than 1,000 volts.

Motor-starter enclosure. An enclosure containing motor starting circuits and equipment.

Nominal voltage. The phase-to-phase or line-to-line root-mean-square value assigned to a circuit or system for designation of its voltage class, such as 480 or 4,160 volts. Actual voltage at which the circuit or system operates may vary from the nominal voltage within a range that permits satisfactory operation of equipment.

Permissible.

(1) As applied to electric face equipment, all electrically operated equipment taken into or used in by the last open crosscut of an entry or a room of any coal mine the electrical parts of which, including, but not limited to, associated electrical equipment, components, and accessories, are designed, constructed, and installed, in accordance with the specifications of the Secretary, to assure that such equipment will not cause a mine explosion or mine fire, and the other features of which are designed and constructed, in accordance with the specifications of the Secretary, to prevent, to the greatest extent possible, other accidents in the use of such equipment. The regulations of the Secretary or the Director of the Bureau of Mines in effect on March 30, 1970, relating to the requirements for investigation, testing, approval, certification, and acceptance of such equipment as permissible shall continue in effect until modified or superseded by the Secretary, except that the Secretary shall provide procedures, including, where feasible, testing, approval, certification, and acceptance in the field by an authorized representative of the Secretary, to facilitate compliance by an operator with the requirements of [§75.500](#) within the periods prescribed in [§75.500](#).

(2) As applied to equipment other than permissible electric face equipment:

(i) Equipment used in the operation of a coal mine to which an approval plate, label, or other device is attached as authorized by the Secretary and which meets specifications which are prescribed by the Secretary for the construction and maintenance of such equipment and are designed to assure that such equipment will not cause a mine explosion or a mine fire.

(ii) The manner of use of equipment means the manner of use prescribed by the Secretary.

Qualified person. As the context requires:

(1) An individual deemed qualified by the Secretary and designated by the operator to make tests and examinations required by this part 75; and

(2) An individual deemed, in accordance with minimum requirements to be established by the Secretary, qualified by training, education, and experience, to perform electrical work, to maintain electrical equipment, and to conduct examinations and tests of all electrical equipment.

Respirable dust. Dust collected with a sampling device approved by the Secretary and the Secretary of Health and Human Services in accordance with part 74--Coal

Mine Dust Personal Sampler Units of this title. Sampling device approvals issued by the Secretary of the Interior and Secretary of Health, Education, and Welfare are continued in effect.

Rock dust. Pulverized limestone, dolomite, gypsum, anhydrite, shale, adobe, or other inert material, preferably light colored, 100 percent of which will pass through a sieve having 20 meshes per linear inch and 70 percent or more of which will pass through a sieve having 200 meshes per linear inch; the particles of which when wetted and dried will not cohere to form a cake which will not be dispersed into separate particles by a light blast of air; and which does not contain more than 5 percent combustible matter or more than a total of 4 percent free and combined silica (SiO₂), or, where the Secretary finds that such silica concentrations are not available, which does not contain more than 5 percent of free and combined silica.

Secretary. The Secretary of Labor or the Secretary's delegate.

Self-Contained Self-Rescuer (SCSR). A type of closed-circuit, self-contained breathing apparatus approved by MSHA and NIOSH under 42 CFR part 84 for escape only from underground mines.

Short circuit. An abnormal connection of relatively low impedance, whether made accidentally or intentionally, between two points of different potential.

Working face. Any place in a coal mine in which work of extracting coal from its natural deposit in the earth is performed during the mining cycle.

Working place. The area of a coal mine inby the last open crosscut.

Working section. All areas of the coal mine from the loading point of the section to and including the working faces.

30 CFR § 75.500

Permissible electric equipment.

[STATUTORY PROVISION]

On and after March 30, 1971:

(a) All junction or distribution boxes used for making multiple power connections inby the last open crosscut shall be permissible;

(b) All handheld electric drills, blower and exhaust fans, electric pumps, and such other low horsepower electric face equipment as the Secretary may designate on or before May 30, 1970, which are taken into or used inby the last open crosscut of any coal mine shall be permissible;

(c) All electric face equipment which is taken into or used inby the last open crosscut of any coal mine classified under any provision of law as gassy prior to March 30,

1970, shall be permissible; and

(d) All other electric face equipment which is taken into or used in by the last crosscut of any coal mine, except a coal mine referred to in [§75.501](#), which has not been classified under any provision of law as a gassy mine prior to March 30, 1970, shall be permissible.

30 CFR § 75.500-1

Other low horsepower electric face equipment.

Other low horsepower electric face equipment designated pursuant to the provisions of [§75.500\(b\)](#) is all other electric-driven mine equipment, except low horsepower rock dusting equipment, and employs an electric current supplied by either a power conductor or battery and consumes not more than 2,250 watts of electricity and which is taken into or used in by the last open crosscut.

30 CFR § 75.501-2

Permissible electric face equipment.

(a) On and after March 30, 1971, in mines operated entirely in coal seams which are located at elevations above the water table:

(a) (1) All junction or distribution boxes used for making multiple power connections in by the last open crosscut shall be permissible; and

(a) (2) All handheld electric drills, blower and exhaust fans, electric pumps, and all other electric-driven mine equipment, except low horsepower rock dusting equipment, that employs an electric current supplied by either a power conductor or battery and consumes not more than 2,250 watts of electricity, which is taken into or used in by the last open crosscut shall be permissible.

(b) On and after March 30, 1974, in mines operated entirely in coal seams which are located at elevations above the water table, all electric face equipment which is taken into or used in by the last crosscut shall be permissible.

30 CFR § 75.508-2

Changes in electric system map; recording.

Changes made in the location, electrical rating or setting within the mine electrical system shall be recorded on the map of such system no later than the end of the next workday following completion of such changes.

30 CFR § 75.509

Electric power circuit and electric equipment; deenergization.

[STATUTORY PROVISIONS]

All power circuits and electric equipment shall be deenergized before work is done on such circuits and equipment, except when necessary for trouble shooting or testing.

30 CFR § 75.511

Low-, medium-, or high-voltage distribution circuits and equipment; repair.

[STATUTORY PROVISION]

No electrical work shall be performed on low-, medium-, or high-voltage distribution circuits or equipment, except by a qualified person or by a person trained to perform electrical work and to maintain electrical equipment under the direct supervision of a qualified person. Disconnecting devices shall be locked out and suitably tagged by the persons who perform such work, except that in cases where locking out is not possible, such devices shall be opened and suitably tagged by such persons. Locks or tags shall be removed only by the persons who installed them or, if such persons are unavailable, by persons authorized by the operator or his agent.

30 CFR § 75.512

Electric equipment; examination, testing and maintenance.

[Statutory Provision]

All electric equipment shall be frequently examined, tested, and properly maintained by a qualified person to assure safe operating conditions. When a potentially dangerous condition is found on electric equipment, such equipment shall be removed from service until such condition is corrected. A record of such examinations shall be kept and made available to an authorized representative of the Secretary and to the miners in such mine.

30 CFR § 75.512-2

Frequency of examinations.

The examinations and tests required by [§75.512](#) shall be made at least weekly. Permissible equipment shall be examined to see that it is in permissible condition.

30 CFR § 75.513

Electric conductor; capacity and insulation.

[STATUTORY PROVISION]

All electric conductors shall be sufficient in size and have adequate current carrying capacity and be of such construction that a rise in temperature resulting from normal operation will not damage the insulating materials.

30 CFR § 75.514
Electrical connections or splices; suitability.

[STATUTORY PROVISION]

All electrical connections or splices in conductors shall be mechanically and electrically efficient, and suitable connectors shall be used. All electrical connections or splices in insulated wire shall be reinsulated at least to the same degree of protection as the remainder of the wire.

30 CFR § 75.515
Cable fittings; suitability.

[STATUTORY PROVISION]

Cables shall enter metal frames of motors, splice boxes, and electric compartments only through proper fittings. When insulated wires other than cables pass through metal frames, the holes shall be substantially bushed with insulated bushings.

30 CFR § 75.516
Power wires; support.

[STATUTORY PROVISION]

All power wires (except trailing cables on mobile equipment, specially designed cables conducting high-voltage power to underground rectifying equipment or transformers, or bare or insulated ground and return wires) shall be supported on well-insulated insulators and shall not contact combustible material, roof, or ribs.

30 CFR § 75.516-2
Communication wires and cables; installation; insulation; support.

(a) All communication wires shall be supported on insulated hangers or insulated J-hooks.

(b) All communication cables shall be insulated as required by [§75.517-1](#), and shall either be supported on insulated or uninsulated hangers or J-hooks, or securely attached to messenger wires, or buried, or otherwise protected against mechanical damage in a manner approved by the Secretary or his authorized representative.

(c) All communication wires and cables installed in track entries shall, except when a communication cable is buried in accordance with paragraph (b) of this section, be installed on the side of the entry opposite to trolley wires and trolley feeder wires. Additional insulation shall be provided for communication circuits at points where they pass over or under any power conductor.

(d) For purposes of this section, communication cable means two or more insulated conductors covered by an additional abrasion-resistant covering.

30 CFR § 75.603

Temporary splice of trailing cable.

[STATUTORY PROVISION]

One temporary splice may be made in any trailing cable. Such trailing cable may only be used for the next 24-hour period. No temporary splice shall be made in a trailing cable within 25 feet of the machine, except cable reel equipment. Temporary splices in trailing cables shall be made in a workmanlike manner and shall be mechanically strong and well insulated. Trailing cables or hand cables which have exposed wires or which have splices that heat or spark under load shall not be used. As used in this section, the term "splice" means the mechanical joining of one or more conductors that have been severed.

30 CFR § 75.604

Permanent splicing of trailing cables.

[STATUTORY PROVISIONS]

When permanent splices in trailing cables are made, they shall be:

- (a) Mechanically strong with adequate electrical conductivity and flexibility;
- (b) Effectively insulated and sealed so as to exclude moisture; and
- (c) Vulcanized or otherwise treated with suitable materials to provide flame-resistant qualities and good bonding to the outer jacket.
- (d) Made using splice kits accepted or approved by MSHA as flame resistant.

30 CFR § 75.605

Clamping of trailing cables to equipment.

[STATUTORY PROVISIONS]

Trailing cables shall be clamped to machines in a manner to protect the cables from damage and to prevent strain on the electrical connections.

30 CFR § 75.605

Clamping of trailing cables to equipment.

[STATUTORY PROVISIONS]

Trailing cables shall be clamped to machines in a manner to protect the cables from damage and to prevent strain on the electrical connections.

30 CFR § 75.606
Protection of trailing cables.

[STATUTORY PROVISIONS]

Trailing cables shall be adequately protected to prevent damage by mobile equipment.

30 CFR § 75.800
High-voltage circuits; circuit breakers.

[STATUTORY PROVISIONS]

High-voltage circuits entering the underground area of any coal mine shall be protected by suitable circuit breakers of adequate interrupting capacity which are properly tested and maintained as prescribed by the Secretary. Such breakers shall be equipped with devices to provide protection against under-voltage grounded phase, short circuit, and overcurrent.

30 CFR § 75.800-1
Circuit breakers; location.

Circuit breakers protecting high-voltage circuits entering an underground area of any coal mine shall be located on the surface and in no case installed either underground or within a drift.

30 CFR § 75.802
Protection of high-voltage circuits extending underground.

(a) Except as provided in paragraph (b) of this section, high-voltage circuits extending underground and supplying portable, mobile, or, stationary high-voltage equipment shall contain either a direct or derived neutral which shall be grounded through a suitable resistor at the source transformers, and a grounding circuit, originating at the grounded side of the grounding resistor, shall extend along with the power conductors and serve as a grounding conductor for the frames of all high-voltage equipment supplied power from that circuit.

(b) Notwithstanding the requirements of paragraph (a) of this section, the Secretary or his authorized representative may permit ungrounded high-voltage circuits to be extended underground to feed stationary electric equipment if:

(1) Such circuits are either steel armored or installed in grounded, rigid steel conduit throughout their entire length; or,

(2) The voltage of such circuits is nominally 2,400 volts or less phase-to-phase and the cables used in such circuits are equipped with metallic shields around each power conductor, and contain one or more ground conductors having a total cross sectional area of not less than one-half the power conductor; and,

(3) Upon a finding by the Secretary or his authorized representative that the use of the circuits described in paragraphs (b)(1) and (2) of this section does not pose a hazard to the miners.

(c) Within 100 feet of the point on the surface where high-voltage circuits enter the underground portion of the mine, disconnecting devices shall be installed and so equipped or designed in such a manner that it can be determined by visual observation that the power is disconnected, except that the Secretary or his authorized representative may permit such devices to be installed at a greater distance from such area of the mine if he determines, based on existing physical conditions, that such installation will be more accessible at a greater distance and will not pose any hazard to the miners.

30 CFR § 75.807

Installation of high-voltage transmission cables.

[STATUTORY PROVISIONS]

All underground high-voltage transmission cables shall be installed only in regularly inspected air courses and haulageways, and shall be covered, buried, or placed so as to afford protection against damage, guarded where men regularly work or pass under them unless they are 6 1/2 feet or more above the floor or rail, securely anchored, properly insulated, and guarded at ends, and covered, insulated, or placed to prevent contact with trolley wires and other low-voltage circuits.

30 CFR § 75.808

Disconnecting devices.

[STATUTORY PROVISIONS]

Disconnecting devices shall be installed at the beginning of branch lines in high-voltage circuits and equipped or designed in such a manner that it can be determined by visual observation that the circuit is deenergized when the switches are open.

30 CFR § 75.809

Identification of circuit breakers and disconnecting switches.

[STATUTORY PROVISIONS]

Circuit breakers and disconnecting switches underground shall be marked for identification

30 CFR § 75.816

Guarding of cables.

- (a) High-voltage cables must be guarded at the following locations:
- (1) Where persons regularly work or travel over or under the cables.
 - (2) Where the cables leave cable handling or support systems to extend to electric components.

(b) Guarding must minimize the possibility of miners contacting the cables and protect the cables from damage. The guarding must be made of grounded metal or nonconductive flame-resistant material.

30 CFR § 75.1002

Installation of electric equipment and conductors; permissibility.

(a) Electric equipment must be permissible and maintained in a permissible condition when such equipment is located within 150 feet of pillar workings or longwall faces.

(b) Electric conductors and cables installed in or inby the last open crosscut or within 150 feet of pillar workings or longwall faces must be--

- (1) Shielded high-voltage cables supplying power to permissible longwall equipment;
- (2) Interconnecting conductors and cables of permissible longwall equipment;
- (3) Conductors and cables of intrinsically safe circuits; and
- (4) Cables and conductors supplying power to low- and medium- voltage permissible equipment.

ELECTRICITY

Questions for Review

Q: What is high voltage?

Q: What are some of the injuries caused by accidental contact with high voltage?

Q: Voltages as low as what can be lethal if contacted?

Q: What is extra-low voltage?

Q: Electrical charges can produce small quantities of what?

Q: Two factors are considered in the classification of "High Voltage." What are they?

Q: Telephone lines and cables should be?

A: CFR 75.516-2

Q: How many temporary splices are permitted in a trailing cable?

A: CFR 75.603

Q: Where shall circuit breakers protecting high voltage circuits entering a mine be located?

A: CFR 75.800-1

Q: How far above the mine floor, in areas where miners pass under them, shall high voltage cables be supported?

A: CFR 75.807

Q: Disconnecting devices shall be installed where?

A: CFR 75.808

Q: High-voltage cables must be guarded at which locations?

A: CFR 75.816

Q: Electric equipment must be permissible and maintained in a permissible condition if it is located where?

A: CFR 75.1002

Q: All electric equipment shall be frequently examined, tested, and properly maintained by a qualified person to assure safe operating conditions. How often must the examinations be done?

A: CFR 75.512

Q: What are the requirements for permanent splices in trailing cables?

A: CFR 75.604

Q: Changes made in the location, electrical rating or setting within the mine electrical system shall be recorded on the map no later than?

A: CFR 75.508-2

CHAPTER FIVE

MINE LAW

1. Federal Mine Safety & Health Act of 1977
2. Code of Federal Regulations - Part 50
3. Code of Federal Regulations - Part 75
4. Utah State Code
5. Questions and Review

**Federal Mine Safety & Health Act of 1977,
Public Law 91-173,
as amended by Public Law 95-164***

Be it enacted by the Senate and House of Representatives of the United States of America in Congress assembled. That this Act may be cited as the "Federal Mine Safety and Health Act of 1977".

FINDINGS AND PURPOSE

SEC. 2. Congress declares that--

- (a) the first priority and concern of all in the coal or other mining industry must be the health and safety of its most precious resource--the miner;
- (b) deaths and serious injuries from unsafe and unhealthful conditions and practices in the coal or other mines cause grief and suffering to the miners and to their families;
- (c) there is an urgent need to provide more effective means and measures for improving the working conditions and practices in the Nation's coal or other mines in order to prevent death and serious physical harm, and in order to prevent occupational diseases originating in such mines;
- (d) the existence of unsafe and unhealthful conditions and practices in the Nation's coal or other mines is a serious impediment to the future growth of the coal or other mining industry and cannot be tolerated;
- (e) the operators of such mines with the assistance of the miners have the primary responsibility to prevent the existence of such conditions and practices in such mines;
- (f) the disruption of production and the loss of income to operators and miners as a result of coal or other mine accidents or occupationally caused diseases unduly impedes and burdens commerce; and
- (g) it is the purpose of this Act (1) to establish interim mandatory health and safety standards and to direct the Secretary of Health, Education, and Welfare and the Secretary of Labor to develop and promulgate improved mandatory health or safety standards to protect the health and safety of the Nation's coal or other miners; (2) to require that each operator of a coal or other mine and every miner in such mine comply with such standards; (3) to cooperate with, and provide assistance to, the States in the development and enforcement of effective State coal or other mine health and safety programs; and (4) to improve and expand, in cooperation with the States and the coal or other mining industry, research and development and training programs aimed at preventing coal or other mine accidents and occupationally caused diseases in the industry.

DEFINITIONS

SEC. 3. For the purpose of this Act, the term--

- (a) "Secretary" means the Secretary of Labor or his delegate;
- (b) "commerce" means trade, traffic, commerce, transportation, or communication among the several States, or between a place in a State and any place outside thereof, or within the District of Columbia or a possession of the United States, or between points in the same State but through a point outside thereof;
- (c) "State" includes a State of the United States, the District of Columbia, the Commonwealth of Puerto Rico, the Virgin Islands, American Samoa, Guam, and the Trust Territory of the Pacific Islands;
- (d) "operator" means any owner, lessee, or other person who operates, controls, or supervises a coal or other mine or any independent contractor performing services or construction at such mine;
- (e) "agent" means any person charged with responsibility for the operation of all or a part of a coal or other mine or the supervision of the miners in a coal or other mine;
- (f) "person" means any individual, partnership, association, corporation, firm, subsidiary of a corporation, or other organization;
- (g) "miner" means any individual working in a coal or other mine;
- (h)(1) "coal or other mine" means (A) an area of land from which minerals are extracted in nonliquid form or, if in liquid form, are extracted with workers underground, (B) private ways and roads appurtenant to such area, and (C) lands, excavations, underground passageways, shafts, slopes, tunnels and workings, structures, facilities, equipment, machines, tools, or other property including impoundments, retention dams, and tailings ponds, on the surface or underground, used in, or to be used in, or resulting from, the work of extracting such minerals from their natural deposits in nonliquid form, or if in liquid form, with workers underground, or used in, or to be used in, the milling of such minerals, or the work of preparing coal or other minerals, and includes custom coal preparation facilities. In making a determination of what constitutes mineral milling for purposes of this Act, the Secretary shall give due consideration to the convenience of administration resulting from the delegation to one Assistant Secretary of all authority with respect to the health and safety of miners employed at one physical establishment;
- (2) For purposes of titles II, III, and IV, "coal mine" means an area of land and all structures, facilities, machinery tools, equipment, shafts, slopes, tunnels, excavations, and other property, real or personal, placed upon, under, or above the surface of such land by any person, used in, or to be used in, or resulting from, the work of extracting in such area bituminous coal, lignite, or anthracite from its natural deposits in the earth by any means or method, and the work of preparing the coal so extracted, and includes custom coal preparation facilities;
- (i) "work of preparing the coal" means the breaking, crushing, sizing, cleaning, washing, drying, mixing, storing and loading of bituminous coal, lignite, or anthracite, and such other work of preparing such coal as is usually done by the operator of the coal mine;
- (j) "imminent danger" means the existence of any condition or practice in a coal or other mine which could reasonably be expected to cause death or serious

physical harm before such condition or practice can be abated;

(k) "accident" includes a mine explosion, mine ignition, mine fire, or mine inundation, or injury to, or death of, any person;

(l) "mandatory health or safety standard" means the interim mandatory health or safety standards established by titles II and III of this Act, and the standards promulgated pursuant to title I of this Act;

(m) "Panel" means the Interim Compliance Panel established by this Act; and

(n) "Administration" means the Mine Safety and Health Administration in the Department of Labor.

(o) "Commission" means the Federal Mine Safety and Health Review Commission.

MINES SUBJECT TO ACT

SEC. 4. Each coal or other mine, the products of which enter commerce, or the operations or products of which affect commerce, and each operator of such mine, and every miner in such mine shall be subject to the provisions of this Act.

INTERIM COMPLIANCE PANEL

SEC. 5. (a) There is hereby established the Interim Compliance Panel, which shall be composed of five members as follows:

(1) Assistant Secretary of Labor for Labor Standards, Department of Labor, or his delegate;

(2) Director of the Bureau of Standards, Department of Commerce, or his delegate;

(3) Administrator of Consumer Protection and Environmental Health Service, Department of Health, Education, and Welfare, or his delegate;

(4) Director of the Bureau of Mines, Department of the Interior, or his delegate; and

(5) Director of the National Science Foundation, or his delegate.

(b) Members of the Panel shall serve without compensation in, addition to that received in their regular employment, but shall be entitled to reimbursement for travel, subsistence, and other necessary expenses incurred by them in the performance of duties vested in the Panel.

(c) Notwithstanding any other provision of law, the Secretary of Health, Education, and Welfare, the Secretary of Commerce, the Secretary of the Interior, and the Secretary shall, upon request of the Panel, provide the Panel such personnel and other assistance as the Panel determines necessary to enable it to carry out its functions under this Act.

(d) Three members of the Panel shall constitute a quorum for doing business. All decisions of the Panel shall be by majority vote. The chairman of the Panel shall be selected by the members from among the membership thereof.

(e) The Panel is authorized to appoint as many hearing examiners as are necessary for proceedings required to be conducted in accordance with the provisions of this Act. The provisions applicable to hearing examiners appointed under section 3105 of title 5 of the

United States Code shall be applicable to hearing examiners appointed pursuant to this subsection.

(f)(1) It shall be the function of the Panel to carry out the duties imposed on it pursuant to this Act and to provide an opportunity for a public hearing, after notice, at the request of an operator of the affected coal mine or the representative of the miners of such mine. Any operator or representative of miners aggrieved by a final decision of the Panel may file a petition for review of such decision under section 106 of this Act. The provisions of this section shall terminate upon completion of the Panel's functions as set forth under this Act. Any hearing held pursuant to this subsection shall be of record and the Panel shall make findings of fact and shall issue a written decision incorporating its findings therein in accordance with section 554 of title 5 of the United States Code.

(2) The Panel shall make an annual report, in writing, to the Secretary for transmittal by him to the Congress concerning the achievement of its purposes, and any other relevant information (including any recommendations) which it deems appropriate.

TITLE I--GENERAL MANDATORY SAFETY AND HEALTH STANDARDS

SEC. 101. (a) The Secretary shall by rule in accordance with procedures set forth in this section and in accordance with section 553 of title 5, United States Code (without regard to any reference in such section to sections 556 and 557 of such title), develop, promulgate, and revise as may be appropriate, improved mandatory health or safety standards for the protection of life and prevention of injuries in coal or other mines.

(1) Whenever the Secretary, upon the basis of information submitted to him in writing by an interested person, a representative of any organization of employers or employees, a nationally recognized standards-producing organization, the Secretary of Health, Education, and Welfare, the National Institute for Occupational Safety and Health, or a State or political subdivision, or on the basis of information developed by the Secretary or otherwise available to him, determines that a rule should be promulgated in order to serve the objectives of this Act, the Secretary may request the recommendation of an advisory committee appointed under section 102(c). The Secretary shall provide such an advisory committee with any proposals of his own or of the Secretary of Health, Education, and Welfare, together with all pertinent factual information developed by the Secretary or the Secretary of Health, Education, and Welfare, or otherwise available, including the results of research, demonstrations, and experiments. An advisory committee shall submit to the Secretary its recommendations regarding the rule to be promulgated within 60 days from the date of its appointment or within such longer or shorter period as may be prescribed by the Secretary, but in no event for a period which is longer than 180 days. When the Secretary receives a recommendation, accompanied by appropriate criteria, from the National Institute for Occupational Safety and Health that a rule be promulgated, modified, or revoked, the Secretary must, within 60 days after receipt thereof, refer such recommendation to an advisory committee pursuant to this paragraph, or publish such as a proposed rule pursuant to paragraph (2), or publish in the Federal Register his determination not to do so, and his reasons therefore. The Secretary shall be required to request the recommendations of an advisory committee appointed under section 102(c) if the rule to be promulgated is, in the discretion of the

Secretary which shall be final, new in effect or application and has significant economic impact.

(2) The Secretary shall publish a proposed rule promulgating, modifying, or revoking a mandatory health or safety standard in the Federal Register. If the Secretary determines that a rule should be proposed and in connection therewith has appointed an advisory committee as provided by paragraph (1), the Secretary shall publish a proposed rule, or the reasons for his determination not to publish such rule, within 60 days following the submission of the advisory committee's recommendation or the expiration of the period of time prescribed by the Secretary in such submission. In either event, the Secretary shall afford interested persons a period of 30 days after any such publication to submit written data or comments on the proposed rule. Such comment period may be extended by the Secretary upon a finding of good cause, which the Secretary shall publish in the Federal Register. Publication shall include the text of such rules proposed in their entirety, a comparative text of the proposed changes in existing rules, and shall include a comprehensive index to the rules, cross-referenced by subject matter.

(3) On or before the last day of the period provided for the submission of written data or comments under paragraph (2), any interested person may file with the Secretary written objections to the proposed mandatory health or safety standard, stating the grounds therefore and requesting a public hearing on such objections. Within 60 days after the last day for filing such objections, the Secretary shall publish in the Federal Register a notice specifying the mandatory health or safety standard to which objections have been filed and a hearing requested, and specifying a time and place for such hearing. Any hearing under this subsection for the purpose of hearing relevant information shall commence within 60 days after the date of publication of the notice of hearing. Hearings required by this subsection shall be conducted by the Secretary, who may prescribe rules and make rulings concerning procedures in such hearings to avoid unnecessary cost or delay. Subject to the need to avoid undue delay, the Secretary shall provide for procedures that will afford interested parties the right to participate in the hearing, including the right to present oral statements and to offer written comments and data. The Secretary may require by subpoena the attendance of witnesses and the production of evidence in connection with any proceeding initiated under this section. If a person refuses to obey a subpoena under this subsection, a United States district court within the jurisdiction of which a proceeding under this subsection is conducted may, upon petition by the Secretary, issue an order requiring compliance with such subpoena. A transcript shall be taken of any such hearing and shall be available to the public.

(4)(A) Within 90 days after certification of the record of the hearing held pursuant to paragraph (3), the Secretary shall by rule promulgate, modify, or revoke such mandatory health or safety standards, and publish his reasons therefore.

(B) In the case of a proposed mandatory health or safety standard to which objections requesting a public hearing have not been filed, the Secretary, within 90 days after the period for filing such objections has expired, shall by rule promulgate, modify, or revoke such mandatory standards, and publish his reasons therefore.

(C) In the event the Secretary determines that a proposed mandatory health or safety standard should not be promulgated he shall, within the times specified in subparagraphs (A) and (B) publish his reasons for his determination.

(5) Any mandatory health or safety standard promulgated as a final rule under this section shall be effective upon publication in the Federal Register unless the Secretary specifies a later date.

(6)(A) The Secretary, in promulgating mandatory standards dealing with toxic materials or harmful physical agents under this subsection, shall set standards which most adequately assure on the basis of the best available evidence that no miner will suffer material impairment of health or functional capacity even if such miner has regular exposure to the hazards dealt with by such standard for the period of his working life. Development of mandatory standards under this subsection shall be based upon research, demonstrations, experiments, and such other information as may be appropriate. In addition to the attainment of the highest degree of health and safety protection for the miner, other considerations shall be the latest available scientific data in the field, the feasibility of the standards, and experience gained under this and other health and safety laws. Whenever practicable, the mandatory health or safety standard promulgated shall be expressed in terms of objective criteria and of the performance desired.

(B) The Secretary of Health, Education, and Welfare, as soon as possible after the date of enactment of the Federal Mine Safety and Health Amendments Act of 1977 but in no event later than 18 months after such date and on a continuing basis thereafter, shall, for each toxic material or harmful physical agent which is used or found in a mine, determine whether such material or agent is potentially toxic at the concentrations in which it is used or found in a mine. The Secretary of Health, Education, and Welfare shall submit such determinations with respect to such toxic substances or harmful physical agents to the Secretary. Thereafter, the Secretary of Health, Education, and Welfare shall submit to the Secretary all pertinent criteria regarding any such substances determined to be toxic or any such harmful agents as such criteria are developed. Within 60 days after receiving any criteria in accordance with the preceding sentence relating to a toxic material or harmful physical agent which is not adequately covered by a mandatory health or safety standard promulgated under this section, the Secretary shall either appoint an advisory committee to make recommendations with respect to a mandatory health or safety standard covering such material or agent in accordance with paragraph (1), or publish a proposed rule promulgating such a mandatory health or safety standard in accordance with paragraph (2), or shall publish his determination not to do so.

(7) Any mandatory health or safety standard promulgated under this subsection shall prescribe the use of labels or other appropriate forms of warning as are necessary to insure that miners are apprised of all hazards to which they are exposed, relevant symptoms and appropriate emergency treatment, and proper conditions and precautions of safe use or exposure. Where appropriate, such mandatory standard shall also prescribe suitable protective equipment and control or technological procedures to be used in connection with such hazards and shall provide for monitoring or measuring miner exposure at such locations and intervals, and in such manner so as to assure the maximum protection of miners. In addition, where appropriate, any such mandatory standard shall prescribe the type and frequency of medical examinations or other tests which shall be made available, by the operator at his cost, to miners exposed to such hazards in order to most effectively determine whether the health of such miners is adversely affected by such exposure. Where appropriate, the mandatory standard shall

provide that where a determination is made that a miner may suffer material impairment of health or functional capacity by reason of exposure to the hazard covered by such mandatory standard, that miner shall be removed from such exposure and reassigned. Any miner transferred as a result of such exposure shall continue to receive compensation for such work at no less than the regular rate of pay for miners in the classification such miner held immediately prior to his transfer. In the event of the transfer of a miner pursuant to the preceding sentence, increases in wages of the transferred miner shall be based upon the new work classification. In the event such medical examinations are in the nature of research, as determined by the Secretary of Health, Education, and Welfare, such examinations may be furnished at the expense of the Secretary of Health, Education, and Welfare. The results of examinations or tests made pursuant to the preceding sentence shall be furnished only to the Secretary or the Secretary of Health, Education, and Welfare, and, at the request of the miner, to his designated physician.

(8) The Secretary shall, to the extent practicable, promulgate separate mandatory health or safety standards applicable to mine construction activity on the surface.

(9) No mandatory health or safety standard promulgated under this title shall reduce the protection afforded miners by an existing mandatory health or safety standard.

(b)(1) The Secretary shall provide, without regard to the requirements of chapter 5, title 5, United States Code, for an emergency temporary mandatory health or safety standard to take immediate effect upon publication in the Federal Register if he determines (A) that miners are exposed to grave danger from exposure to substances or agents determined to be toxic or physically harmful, or to other hazards, and (B) that such emergency standard is necessary to protect miners from such danger.

(2) A temporary mandatory health or safety standard shall be effective until superseded by a mandatory standard promulgated in accordance with the procedures prescribed in paragraph (3) of this subsection.

(3) Upon publication of such standard in the Federal Register, the Secretary shall commence a proceeding in accordance with section 101 (a), and the standards as published shall also serve as a proposed rule for the proceeding. The Secretary shall promulgate a mandatory health or safety standard under this paragraph no later than nine months after publication of the emergency temporary standard as provided in paragraph (2).

(c) Upon petition by the operator or the representative of miners, the Secretary may modify the application of any mandatory safety standard to a coal or other mine if the Secretary determines that an alternative method of achieving the result of such standard exists which will at all times guarantee no less than the same measure of protection afforded the miners of such mine by such standard, or that the application of such standard to such mine will result in a diminution of safety to the miners in such mine. Upon receipt of such petition the Secretary shall publish notice thereof and give notice to the operator or the representative of miners in the affected mine, as appropriate, and shall cause such investigation to be made as he deems appropriate. Such investigation shall provide an opportunity for a public hearing at the request of such operator or representative or other interested party, to enable the operator or the representative of

miners in such mine or other interested party to present information relating to the modification of such standard. Before granting any exception to a mandatory safety standard, the findings of the Secretary or his authorized representative shall be made public and shall be available to the representative of the miners at the affected mine. The Secretary shall issue a decision incorporating his findings of fact therein, and send a copy thereof to the operator or the representative of the miners, as appropriate. Any such hearing shall be of record and shall be subject to section 554 of title 5 of the United States Code.

(d) Any person who may be adversely affected by a mandatory health or safety standard promulgated under this section may, at any time prior to the sixtieth day after such standard is promulgated, file a petition challenging the validity of such mandatory standard with the United States Court of Appeals for the District of Columbia Circuit or the circuit wherein such person resides or has his principal place of business, for a judicial review of such standard. A copy of the petition shall be forthwith transmitted by the clerk of the court to the Secretary. The filing of such petition shall not, unless otherwise ordered by the court, operate as a stay of the standard. No objection that has not been urged before the Secretary shall be considered by the court, unless the failure or neglect to urge such objection shall be excused for good cause shown. The validity of any mandatory health or safety standard shall not be subject to challenge on the grounds that any of the time limitations in this section have been exceeded. The procedures of this subsection shall be the exclusive means of challenging the validity of a mandatory health or safety standard.

(e) The Secretary shall send a copy of every proposed mandatory health or safety standard or regulation at the time of publication in the Federal Register to the operator of each coal or other mine and the representative of the miners at such mine and such copy shall be immediately posted on the bulletin board of the mine by the operator or his agent, but failure to receive such notice shall not relieve anyone of the obligation to comply with such standard or regulation.

ADVISORY COMMITTEES

SEC. 102. (a)(1) The Secretary of the Interior shall appoint an advisory committee on coal or other mine safety research composed of--

(A) the Director of the Office of Science and Technology or his delegate, with the consent of the Director;

(B) the Director of the National Bureau of Standards, Department of Commerce, or his delegate, with the consent of the Director;

(C) the Director of the National Science Foundation, or his delegate, with the consent of the Director; and

(D) such other persons as the Secretary of the Interior may appoint who are knowledgeable in the field of coal or other mine safety research. The Secretary of the Interior shall designate the chairman of the committee.

(2) The advisory committee shall consult with, and make recommendations to, the Secretary of the Interior on matters involving or relating to coal or other mine safety research. The Secretary of the Interior shall consult with, and consider the

recommendations of, such committee in the conduct of such research, the making of any grants, and the entering into of contracts for such research.

(3) The chairman of the committee and a majority of the persons appointed by the Secretary of the Interior pursuant to paragraph (1)(D) shall be individuals who have no economic interests in the coal or other mining industry, and who are not operators, miners, or officers or employees of the Federal Government or any State or local government.

(b)(1) The Secretary of Health, Education, and Welfare shall appoint an advisory committee on coal or other mine health research composed of--

(A) the Director, Bureau of Mines, or his delegate, with the consent of the Director;

(B) the Director of the National Science Foundation, or his delegate, with the consent of the Director;

(C) the Director of the National Institutes of Health, or his delegate, with the consent of the Director; and

(D) such other persons as the Secretary of Health, Education, and Welfare may appoint who are knowledgeable in the field of coal or other mine health research. The Secretary of Health, Education, and Welfare shall designate the chairman of the committee.

(2) The advisory committee shall consult with, and make recommendations to, the Secretary of Health, Education, and Welfare on matters involving or relating to coal or other mine health research. The Secretary of Health, Education, and Welfare shall consult with, and consider the recommendations of, such committee in the conduct of such research, the making of any grants, and the entering into of contracts for such research.

(3) The chairman of the committee and a majority of the persons appointed by the Secretary of Health, Education, and Welfare pursuant to paragraph (1)(D) shall be individuals who have no economic interests in the coal or other mining industry, and who are not operators, miners, or officers or employees of the Federal Government or any State or local government.

(c) The Secretary or the Secretary of Health, Education, and Welfare may appoint other advisory committees as he deems appropriate to advise him in carrying out the provisions of this Act. The Secretary or the Secretary of Health, Education, and Welfare, as the case may be, shall appoint the chairman of each such committee. A majority of the members (including the chairman) of any such advisory committee appointed pursuant to this subsection shall be composed of individuals who have no economic interests in the coal or other mining industry, and who are not operators, miners, or officers or employees of the Federal Government or any State or local government.

(d) Advisory committee members, other than officers or employees of Federal, State, or local governments, shall be, for each day (including travel time) during which they are performing committee business, entitled to receive compensation at a rate fixed by the appropriate Secretary but not in excess of the maximum rate of pay for grade GS-18 as provided in the General Schedule under section 5332 of title 5 of the United States Code,

and shall, notwithstanding the limitations of sections 5703 and 5704 of title 5 of the United States Code, be fully reimbursed for travel, subsistence, and related expenses.

INSPECTIONS, INVESTIGATIONS, AND RECORDKEEPING

SEC. 103. (a) Authorized representatives of the Secretary or the Secretary of Health, Education, and Welfare shall make frequent inspections and investigations in coal or other mines each year for the purpose of (1) obtaining, utilizing, and disseminating information relating to health and safety conditions, the causes of accidents, and the causes of diseases and physical impairments originating in such mines, (2) gathering information with respect to mandatory health or safety standards, (3) determining whether an imminent danger exists, and (4) determining whether there is compliance with the mandatory health or safety standards or with any citation, order, or decision issued under this title or other requirements of this Act. In carrying out the requirements of this subsection, no advance notice of an inspection shall be provided to any person, except that in carrying out the requirements of clauses (1) and (2) of this subsection, the Secretary of Health, Education, and Welfare may give advance notice of inspections. In carrying out the requirements of clauses (3) and (4) of this subsection, the Secretary shall make inspections of each underground coal or other mine in its entirety at least four times a year, and of each surface coal or other mine in its entirety at least two times a year. The Secretary shall develop guidelines for additional inspections of mines based on criteria including, but not limited to, the hazards found in mines subject to this Act, and his experience under this Act and other health and safety laws. For the purpose of making any inspection or investigation under this Act, the Secretary, or the Secretary of Health, Education, and Welfare, with respect to fulfilling his responsibilities under this Act, or any authorized representative of the Secretary or the Secretary of Health, Education, and Welfare, shall have a right of entry to, upon, or through any coal or other mine.

(b) For the purpose of making any investigation of any accident or other occurrence relating to health or safety in a coal or other mine, the Secretary may, after notice, hold public hearings, and may sign and issue subpoenas for the attendance and testimony of witnesses and the production of relevant papers, books, and documents, and administer oaths. Witnesses summoned shall be paid the same fees and mileage that are paid witnesses in the courts of the United States. In case of contumacy or refusal to obey a subpoena served upon any person under this section, the district court of the United States for any district in which such person is found or resides or transacts business, upon application by the United States and after notice to such person, shall have jurisdiction to issue an order requiring such person to appear and give testimony before the Secretary or to appear and produce documents before the Secretary, or both, and any failure to obey such order of the court may be punished by such court as a contempt thereof.

(c) The Secretary, in cooperation with the Secretary of Health, Education, and Welfare, shall issue regulations requiring operators to maintain accurate records of employee exposures to potentially toxic materials or harmful physical agents which are required to be monitored or measured under any applicable mandatory health or safety standard promulgated under this Act. Such regulations shall provide miners or their representatives with an opportunity to observe such monitoring or measuring, and to have access to the records thereof. Such regulations shall also make appropriate

provisions for each miner or former miner to have access to such records as will indicate his own exposure to toxic materials or harmful physical agents. Each operator shall promptly notify any miner who has been or is being exposed to toxic materials or harmful physical agents in concentrations or at levels which exceed those prescribed by an applicable mandatory health or safety standard promulgated under section 101, or mandated under title II, and shall inform any miner who is being thus exposed of the corrective action being taken.

(d) All accidents, including unintentional roof falls (except in any abandoned panels or in areas which are inaccessible or unsafe for inspections), shall be investigated by the operator or his agent to determine the cause and the means of preventing a recurrence. Records of such accidents and investigations shall be kept and the information shall be made available to the Secretary or his authorized representative and the appropriate State agency. Such records shall be open for inspection by interested persons. Such records shall include man-hours worked and shall be reported at a frequency determined by the Secretary, but at least annually.

(e) Any information obtained by the Secretary or by the Secretary of Health, Education, and Welfare under this Act shall be obtained in such a manner as not to impose an unreasonable burden upon operators, especially those operating small businesses, consistent with the underlying purposes of this Act. Unnecessary duplication of effort in obtaining information shall be reduced to the maximum extent feasible.

(f) Subject to regulations issued by the Secretary, a representative of the operator and a representative authorized by his miners shall be given an opportunity to accompany the Secretary or his authorized representative during the physical inspection of any coal or other mine made pursuant to the provisions of subsection (a), for the purpose of aiding such inspection and to participate in pre- or post-inspection conferences held at the mine. Where there is no authorized miner representative, the Secretary or his authorized representative shall consult with a reasonable number of miners concerning matters of health and safety in such mine. Such representative of miners who is also an employee of the operator shall suffer no loss of pay during the period of his participation in the inspection made under this subsection. To the extent that the Secretary or authorized representative of the Secretary determines that more than one representative from each party would further aid the inspection, he can permit each party to have an equal number of such additional representatives. However, only one such representative of miners who is an employee of the operator shall be entitled to suffer no loss of pay during the period of such participation under the provisions of this subsection. Compliance with this subsection shall not be a jurisdictional prerequisite to the enforcement of any provision of this Act.

(g)(1) Whenever a representative of the miners or a miner in the case of a coal or other mine where there is no such representative has reasonable grounds to believe that a violation of this Act or a mandatory health or safety standard exists, or an imminent danger exists, such miner or representative shall have a right to obtain an immediate inspection by giving notice to the Secretary or his authorized representative of such violation or danger. Any such notice shall be reduced to writing, signed by the representative of the miners or by the miner, and a copy shall be provided the operator or his agent no later than at the time of inspection, except that the operator or his agent shall be notified forthwith if the complaint indicates that an imminent danger exists. The

name of the person giving such notice and the names of individual miners referred to therein shall not appear in such copy or notification. Upon receipt of such notification, a special inspection shall be made as soon as possible to determine if such violation or danger exists in accordance with the provisions of this title. If the Secretary determines that a violation or danger does not exist, he shall notify the miner or representative of the miners in writing of such determination.

(2) Prior to or during any inspection of a coal or other mine, any representative of miners or a miner in the case of a coal or other mine where there is no such representative, may notify the Secretary or any representative of the Secretary responsible for conducting the inspection, in writing, of any violation of this Act or of any imminent danger which he has reason to believe exists in such mine. The Secretary shall, by regulation, establish procedures for informal review of any refusal by a representative of the Secretary to issue a citation with respect to any such alleged violation or order with respect to such danger and shall furnish the representative of miners or miner requesting such review a written statement of the reasons for the Secretary's final disposition of the case.

(h) In addition to such records as are specifically required by this Act, every operator of a coal or other mine shall establish and maintain such records, make such reports, and provide such information, as the Secretary or the Secretary of Health, Education, and Welfare may reasonably require from time to time to enable him to perform his functions under this Act. The Secretary or the Secretary of Health, Education, and Welfare is authorized to compile, analyze, and publish, either in summary or detailed form, such reports or information so obtained. Except to the extent otherwise specifically provided by this Act, all records, information, reports, findings, citations, notices, orders, or decisions required or issued pursuant to or under this Act may be published from time to time, may be released to any interested person, and shall be made available for public inspection.

(i) Whenever the Secretary finds that a coal or other mine liberates excessive quantities of methane or other explosive gases during its operations, or that a methane or other gas ignition or explosion has occurred in such mine which resulted in death or serious injury at any time during the previous five years, or that there exists in such mine some other especially hazardous condition, he shall provide a minimum of one spot inspection by his authorized representative of all or part of such mine during every five working days at irregular intervals. For purposes of this subsection, "liberation of excessive quantities of methane or other explosive gases" shall mean liberation of more than one million cubic feet of methane or other explosive gases during a 24-hour period. When the Secretary finds that a coal or other mine liberates more than five hundred thousand cubic feet of methane or other explosive gases during a 24-hour period, he shall provide a minimum of one spot inspection by his authorized representative of all or part of such mine every 10 working days at irregular intervals. When the Secretary finds that a coal or other mine liberates more than two hundred thousand cubic feet of methane or other explosive gases during a 24-hour period, he shall provide a minimum of one spot inspection by his authorized representative of all or part of such mine every 15 working days at irregular intervals.

(j) In the event of any accident occurring in any coal or other mine, the operator shall notify the Secretary thereof and shall take appropriate measures to prevent the

destruction of any evidence which would assist in investigating the cause or causes thereof. In the event of any accident occurring in a coal or other mine, where rescue and recovery work is necessary, the Secretary or an authorized representative of the Secretary shall take whatever action he deems appropriate to protect the life of any person, and he may, if he deems it appropriate, supervise and direct the rescue and recovery activities in such mine.

(k) In the event of any accident occurring in a coal or other mine, an authorized representative of the Secretary, when present, may issue such orders as he deems appropriate to insure the safety of any person in the coal or other mine, and the operator of such mine shall obtain the approval of such representative, in consultation with appropriate State representatives, when feasible, of any plan to recover any person in such mine or to recover the coal or other mine or return affected areas of such mine to normal.

CITATIONS AND ORDERS

SEC. 104. (a) If, upon inspection or investigation, the Secretary or his authorized representative believes that an operator of a coal or other mine subject to this Act has violated this Act, or any mandatory health or safety standard, rule, order, or regulation promulgated pursuant to this Act, he shall, with reasonable promptness, issue a citation to the operator. Each citation shall be in writing and shall describe with particularity the nature of the violation, including a reference to the provision of the Act, standard, rule, regulation, or order alleged to have been violated. In addition, the citation shall fix a reasonable time for the abatement of the violation. The requirement for the issuance of a citation with reasonable promptness shall not be a jurisdictional prerequisite to the enforcement of any provision of this Act.

(b) If, upon any follow-up inspection of a coal or other mine, an authorized representative of the Secretary finds (1) that a violation described in a citation issued pursuant to subsection (a) has not been totally abated within the period of time as originally fixed therein or as subsequently extended, and (2) that the period of time for the abatement should not be further extended, he shall determine the extent of the area affected by the violation and shall promptly issue an order requiring the operator of such mine or his agent to immediately cause all persons, except those persons referred to in subsection (c), to be withdrawn from, and to be prohibited from entering, such area until an authorized representative of the Secretary determines that such violation has been abated.

(c) The following persons shall not be required to be withdrawn from, or prohibited from entering, any area of the coal or other mine subject to an order issued under this section:

- (1) any person whose presence in such area is necessary, in the judgment of the operator or an authorized representative of the Secretary, to eliminate the condition described in the order;
- (2) any public official whose official duties require him to enter such area;
- (3) any representative of the miners in such mine who is, in the judgment of the operator or an authorized representative of the Secretary, qualified to make such mine examinations or who is accompanied by such a person and whose presence

in such area is necessary for the investigation of the conditions described in the order; and

(4) any consultant to any of the foregoing.

(d)(1) If, upon any inspection of a coal or other mine, an authorized representative of the Secretary finds that there has been a violation of any mandatory health or safety standard, and if he also finds that, while the conditions created by such violation do not cause imminent danger, such violation is of such nature as could significantly and substantially contribute to the cause and effect of a coal or other mine safety or health hazard, and if he finds such violation to be caused by an unwarrantable failure of such operator to comply with such mandatory health or safety standards, he shall include such finding in any citation given to the operator under this Act. If, during the same inspection or any subsequent inspection of such mine within 90 days after the issuance of such citation, an authorized representative of the Secretary finds another violation of any mandatory health or safety standard and finds such violation to be also caused by an unwarrantable failure of such operator to so comply, he shall forthwith issue an order requiring the operator to cause all persons in the area affected by such violation, except those persons referred to in subsection (c) to be withdrawn from, and to be prohibited from entering, such area until an authorized representative of the Secretary determines that such violation has been abated.

(2) If a withdrawal order with respect to any area in a coal or other mine has been issued pursuant to paragraph (1), a withdrawal order shall promptly be issued by an authorized representative of the Secretary who finds upon any subsequent inspection the existence in such mine of violations similar to those that resulted in the issuance of the withdrawal order under paragraph (1) until such time as an inspection of such mine discloses no similar violations. Following an inspection of such mine which discloses no similar violations, the provisions of paragraph (1) shall again be applicable to that mine.

(e)(1) If an operator has a pattern of violations of mandatory health or safety standards in the coal or other mine which are of such nature as could have significantly and substantially contributed to the cause and effect of coal or other mine health or safety hazards, he shall be given written notice that such pattern exists. If, upon any inspection within 90 days after the issuance of such notice, an authorized representative of the Secretary finds any violation of a mandatory health or safety standard which could significantly and substantially contribute to the cause and effect of a coal or other mine safety or health hazard, the authorized representative shall issue an order requiring the operator to cause all persons in the area affected by such violation, except those persons referred to in subsection (c), to be withdrawn from, and to be prohibited from entering, such area until an authorized representative of the Secretary determines that such violation has been abated.

(2) If a withdrawal order with respect to any area in a coal or other mine has been issued pursuant to paragraph (1), a withdrawal order shall be issued by an authorized representative of the Secretary who finds upon any subsequent inspection the existence in such mine of any violation of a mandatory health or safety standard which could significantly and substantially contribute to the cause and effect of a coal or other mine health or safety hazard. The withdrawal order shall remain in effect until an authorized representative of the Secretary determines that such violation has been abated.

(3) If, upon an inspection of the entire coal or other mine, an authorized representative of the Secretary finds no violations of mandatory health or safety standards that could significantly and substantially contribute to the cause and effect of a coal or other mine health and safety hazard, the pattern of violations that resulted in the issuance of a notice under paragraph (1) shall be deemed to be terminated and the provisions of paragraphs (1) and (2) shall no longer apply. However, if as a result of subsequent violations, the operator reestablishes a pattern of violations, paragraphs (1) and (2) shall again be applicable to such operator.

(4) The Secretary shall make such rules as he deems necessary to establish criteria for determining when a pattern of violations of mandatory health or safety standards exists.

(f) If, based upon samples taken, analyzed, and recorded pursuant to section 202(a), or samples taken during an inspection by an authorized representative of the Secretary, the applicable limit on the concentration of respirable dust required to be maintained under this Act is exceeded and thereby violated, the Secretary or his authorized representative shall issue a citation fixing a reasonable time for the abatement of the violation. During such time, the operator of the mine shall cause samples described in section 202(a) to be taken of the affected area during each production shift. If, upon the expiration of the period of time as originally fixed or subsequently extended, the Secretary or his authorized representative finds that the period of time should not be further extended, he shall determine the extent of the area affected by the violation and shall promptly issue an order requiring the operator of such mine or his agent to cause immediately all persons, except those referred to in subsection (c), to be withdrawn from, and to be prohibited from entering, such area until the Secretary or his authorized representative has reason to believe, based on actions taken by the operator, that such limit will be complied with upon the resumption of production in such mine. As soon as possible after an order is issued, the Secretary, upon request of the operator, shall dispatch to the mine involved a person, or team of persons, to the extent such persons are available, who are knowledgeable in the methods and means of controlling and reducing respirable dust. Such person or team of persons shall remain at the mine involved for such time as they shall deem appropriate to assist the operator in reducing respirable dust concentrations. While at the mine, such persons may require the operator to take such actions as they deem appropriate to insure the health of any person in the coal or other mine.

(g)(1) If, upon any inspection or investigation pursuant to section 103 of this Act, the Secretary or an authorized representative shall find employed at a coal or other mine a miner who has not received the requisite safety training as determined under section 115 of this Act, the Secretary or an authorized representative shall issue an order under this section which declares such miner to be a hazard to himself and to others, and requiring that such miner be immediately withdrawn from the coal or other mine, and be prohibited from entering such mine until an authorized representative of the Secretary determines that such miner has received the training required by section 115 of this Act.

(2) No miner who is ordered withdrawn from a coal or other mine under paragraph (1) shall be discharged or otherwise discriminated against because of such order; and no miner who is ordered withdrawn from a coal or other mine under paragraph (1) shall suffer a loss of compensation during the period necessary for such miner to receive such

training and for an authorized representative of the Secretary to determine that such miner has received the requisite training.

(h) Any citation or order issued under this section shall remain in effect until modified, terminated or vacated by the Secretary or his authorized representative, or modified, terminated or vacated by the Commission or the courts pursuant to section 105 or 106.

PROCEDURE FOR ENFORCEMENT

SEC. 105. (a) If, after an inspection or investigation, the Secretary issues a citation or order under section 104, he shall, within a reasonable time after the termination of such inspection or investigation, notify the operator by certified mail of the civil penalty proposed to be assessed under section 110(a) for the violation cited and that the operator has 30 days within which to notify the Secretary that he wishes to contest the citation or proposed assessment of penalty. A copy of such notification shall be sent by mail to the representative of miners in such mine. If, within 30 days from the receipt of the notification issued by the Secretary, the operator fails to notify the Secretary that he intends to contest the citation or the proposed assessment of penalty, and no notice is filed by any miner or representative of miners under subsection (d) of this section within such time, the citation and the proposed assessment of penalty shall be deemed a final order of the Commission and not subject to review by any court or agency. Refusal by the operator or his agent to accept certified mail containing a citation and proposed assessment of penalty under this subsection shall constitute receipt thereof within the meaning of this subsection.

(b)(1)(A) If the Secretary has reason to believe that an operator has failed to correct a violation for which a citation has been issued within the period permitted for its correction, the Secretary shall notify the operator by certified mail of such failure and of the penalty proposed to be assessed under section 110(b) by reason of such failure and that the operator has 30 days within which to notify the Secretary that he wishes to contest the Secretary's notification of the proposed assessment of penalty. A copy of such notification of the proposed assessment of penalty shall at the same time be sent by mail to the representative of the mine employees. If, within 30 days from the receipt of notification of proposed assessment of penalty issued by the Secretary, the operator fails to notify the Secretary that he intends to contest the notification of proposed assessment of penalty, such notification shall be deemed a final order of the Commission and not subject to review by any court or agency. Refusal by the operator or his agent to accept certified mail containing a notification of proposed assessment of penalty issued under this subsection shall constitute receipt thereof within the meaning of this subsection.

(B) In determining whether to propose a penalty to be assessed under section 110(b), the Secretary shall consider the operator's history of previous violations, the appropriateness of such penalty to the size of the business of the operator charged, whether the operator was negligent, the effect on the operator's ability to continue in business, the gravity of the violation, and the demonstrated good faith of the operator charged in attempting to achieve rapid compliance after notification of a violation.

(2) An applicant may file with the Commission a written request that the Commission grant temporary relief from any modification or termination of any order or from any

order issued under section 104 together with a detailed statement giving the reasons for granting such relief. The Commission may grant such relief under such conditions as it may prescribe, if--

(A) a hearing has been held in which all parties were given an opportunity to be heard;

(B) the applicant shows that there is substantial likelihood that the findings of the Commission will be favorable to the applicant; and

(C) such relief will not adversely affect the health and safety of miners.

No temporary relief shall be granted in the case of a citation issued under subsection (a) or (f) of section 104. The Commission shall provide a procedure for expedited consideration of applications for temporary relief under this paragraph.

(c)(1) No person shall discharge or in any manner discriminate against or cause to be discharged or cause discrimination against or otherwise interfere with the exercise of the statutory rights of any miner, representative of miners or applicant for employment in any coal or other mine subject to this Act because such miner, representative of miners or applicant for employment has filed or made a complaint under or related to this Act, including a complaint notifying the operator or the operator's agent, or the representative of the miners at the coal or other mine of an alleged danger or safety or health violation in a coal or other mine, or because such miner, representative of miners or applicant for employment is the subject of medical evaluations and potential transfer under a standard published pursuant to section 101 or because such miner, representative of miners or applicant for employment has instituted or caused to be instituted any proceeding under or related to this Act or has testified or is about to testify in any such proceeding, or because of the exercise by such miner, representative of miners or applicant for employment on behalf of himself or others of any statutory right afforded by this Act.

(2) Any miner or applicant for employment or representative of miners who believes that he has been discharged, interfered with, or otherwise discriminated against by any person in violation of this subsection may, within 60 days after such violation occurs, file a complaint with the Secretary, alleging such discrimination. Upon receipt of such complaint, the Secretary shall forward a copy of the complaint to the respondent and shall cause such investigation to be made as he deems appropriate. Such investigation shall commence within 15 days of the Secretary's receipt of the complaint, and if the Secretary finds that such complaint was not frivolously brought, the Commission, on an expedited basis upon application of the Secretary, shall order the immediate reinstatement of the miner pending final order on the complaint. If upon such investigation, the Secretary determines that the provisions of this subsection have been violated, he shall immediately file a complaint with the Commission, with service upon the alleged violator and the miner, applicant for employment, or representative of miners alleging such discrimination or interference and propose an order granting appropriate relief. The Commission shall afford an opportunity for a hearing; (in accordance with section 554 of title 5, United States Code, but without regard to subsection (a)(3) of such section) and thereafter shall issue an order, based upon findings of fact, affirming, modifying, or vacating the Secretary's proposed order, or directing other appropriate relief. Such order shall become final 30 days after its issuance. The Commission shall have authority in such proceedings to require a person committing a violation of this subsection to take such affirmative action to abate the

violation as the Commission deems appropriate, including, but not limited to, the rehiring or reinstatement of the miner to his former position with back pay and interest. The complaining miner, applicant, or representative of miners may present additional evidence on his own behalf during any hearing held pursuant to this paragraph.

(3) Within 90 days of the receipt of a complaint filed under paragraph (2), the Secretary shall notify, in writing, the miner, applicant for employment, or representative of miners of his determination whether a violation has occurred. If the Secretary, upon investigation, determines that the provisions of this subsection have not been violated, the complainant shall have the right, within 30 days of notice of the Secretary's determination, to file an action in his own behalf before the Commission, charging discrimination or interference in violation of paragraph (1). The Commission shall afford an opportunity for a hearing (in accordance with section 554 of title 5, United States Code, but without regard to subsection (a)(3) of such section), and thereafter shall issue an order, based upon findings of fact, dismissing or sustaining the complainant's charges and, if the charges are sustained, granting such relief as it deems appropriate, including, but not limited to, an order requiring the rehiring or reinstatement of the miner to his former position with back pay and interest or such remedy as may be appropriate. Such order shall become final 30 days after its issuance. Whenever an order is issued sustaining the complainant's charges under this subsection, a sum equal to the aggregate amount of all costs and expenses (including attorney's fees) as determined by the Commission to have been reasonably incurred by the miner, applicant for employment or representative of miners for, or in connection with, the institution and prosecution of such proceedings shall be assessed against the person committing such violation. Proceedings under this section shall be expedited by the Secretary and the Commission. Any order issued by the Commission under this paragraph shall be subject to judicial review in accordance with section 106. Violations by any person of paragraph (1) shall be subject to the provisions of sections 108 and 110(a).

(d) If, within 30 days of receipt thereof, an operator of a coal or other mine notifies the Secretary that he intends to contest the issuance or modification of an order issued under section 104, or citation or a notification of proposed assessment of a penalty issued under subsection (a) or (b) of this section, or the reasonableness of the length of abatement time fixed in a citation or modification thereof issued under section 104, or any miner or representative of miners notifies the Secretary of an intention to contest the issuance, modification, or termination of any order issued under section 104, or the reasonableness of the length of time set for abatement by a citation or modification thereof issued under section 104, the Secretary shall immediately advise the Commission of such notification, and the Commission shall afford an opportunity for a hearing (in accordance with section 554 of title 5, United States Code, but without regard to subsection (a)(3) of such section), and thereafter shall issue an order, based on findings of fact, affirming, modifying, or vacating the Secretary's citation, order, or proposed penalty, or directing other appropriate relief. Such order shall become final 30 days after its issuance. The rules of procedure prescribed by the Commission shall provide affected miners or representatives of affected miners an opportunity to participate as parties to hearings under this section. The Commission shall take whatever action is necessary to expedite proceedings for hearing appeals of orders issued under section 104.

JUDICIAL REVIEW

SEC. 106. (a)(1) Any person adversely affected or aggrieved by an order of the Commission issued under this Act may obtain a review of such order in any United States court of appeals for the circuit in which the violation is alleged to have occurred or in the United States Court of Appeals for the District of Columbia Circuit, by filing in such court within 30 days following the issuance of such order a written petition praying that the order be modified or set aside. A copy of such petition shall be forthwith transmitted by the clerk of the court to the Commission and to the other parties, and thereupon the Commission shall file in the court the record in the proceeding as provided in section 2112 of title 28, United States Code. Upon such filing, the court shall have exclusive jurisdiction of the proceeding and of the questions determined therein, and shall have the power to make and enter upon the pleadings, testimony, and proceedings set forth in such record a decree affirming, modifying, or setting aside, in whole or in part, the order of the Commission and enforcing the same to the extent that such order is affirmed or modified. No objection that has not been urged before the Commission shall be considered by the court, unless the failure or neglect to urge such objection shall be excused because of extraordinary circumstances. The findings of the Commission with respect to questions of fact, if supported by substantial evidence on the record considered as a whole, shall be conclusive. If any party shall apply to the court for leave to adduce additional evidence and shall show to the satisfaction of the court that such additional evidence is material and that there were reasonable grounds for the failure to adduce such evidence in the hearing before the Commission, the court may order such additional evidence to be taken before the Commission and to be made a part of the record. The Commission may modify its findings as to the facts, or make new findings, by reason of additional evidence so taken and filed, and it shall file such modified or new findings, which findings with respect to questions of fact, if supported by substantial evidence on the record considered as a whole, shall be conclusive. The Commission may modify or set aside its original order by reason of such modified or new findings of fact. Upon the filing of the record after such remand proceedings, the jurisdiction of the court shall be exclusive and its judgment and decree shall be final, except that the same shall be subject to review by the Supreme Court of the United States, as provided in section 1254 of title 28, United States Code. Petitions filed under this subsection shall be heard expeditiously.

(2) In the case of a proceeding to review any order or decision issued by the Commission under this Act, except an order or decision pertaining to an order issued under section 107 (a) or an order or decision pertaining to a citation issued under section 104(a) or (f), the court may, under such conditions as it may prescribe, grant such temporary relief as it deems appropriate pending final determination of the proceeding, if

- (A) all parties to the proceeding have been notified and given an opportunity to be heard on a request for temporary relief;
- (B) the person requesting such relief shows that there is a substantial likelihood that he will prevail on the merits of the final determination of the proceeding; and
- (C) such relief will not adversely affect the health and safety of miners in the coal or other mine.

(3) In the case of a proceeding to review any order or decision issued by the Panel under this Act, the court may, under such conditions as it may prescribe, grant such temporary relief as it deems appropriate pending final determination of the proceeding, if--

(A) all parties to the proceeding have been notified and given an opportunity to be heard on a request for temporary relief; and

(B) the person requesting such relief shows that there is a substantial likelihood that he will prevail on the merits of the final determination of the proceeding.

(b) The Secretary may also obtain review or enforcement of any final order of the Commission by filing a petition for such relief in the United States court of appeals for the circuit in which the alleged violation occurred or in the Court of Appeals for the District of Columbia Circuit, and the provisions of subsection (a) shall govern such proceedings to the extent applicable. If no petition for review, as provided in subsection (a), is filed within 30 days after issuance of the Commission's order, the Commission's findings of fact and order shall be conclusive in connection with any petition for enforcement which is filed by the Secretary after the expiration of such 30-day period. In any such case, as well as in the case of a noncontested citation or notification by the Secretary which has become a final order of the Commission under subsection (a) or (b) of section 105, the clerk of the court, unless otherwise ordered by the court, shall forthwith enter a decree enforcing the order and shall transmit a copy of such decree to the Secretary and the operator named in the petition. In any contempt proceeding brought to enforce a decree of a court of appeals entered pursuant to this subsection or subsection (a), the court of appeals may assess the penalties provided in section 110, in addition to invoking any other available remedies.

(c) The commencement of a proceeding under this section shall not, unless specifically ordered by the court, operate as a stay of the order or decision of the Commission or the Panel.

PROCEDURES TO COUNTERACT DANGEROUS CONDITIONS

SEC. 107. (a) If, upon any inspection or investigation of a coal or other mine which is subject to this Act, an authorized representative of the Secretary finds that an imminent danger exists, such representative shall determine the extent of the area of such mine throughout which the danger exists, and issue an order requiring the operator of such mine to cause all persons, except those referred to in section 104(c), to be withdrawn from, and to be prohibited from entering, such area until an authorized representative of the Secretary determines that such imminent danger and the conditions or practices which caused such imminent danger no longer exist. The issuance of an order under this subsection shall not preclude the issuance of a citation under section 104 or the proposing of a penalty under section 110.

(b)(1) If, upon any inspection of a coal or other mine, an authorized representative of the Secretary finds (A) that conditions exist therein which have not yet resulted in an imminent danger, (B) that such conditions cannot be effectively abated through the use of existing technology, and (C) that reasonable assurance cannot be provided that the continuance of mining operations under such conditions will not result in an imminent danger, he shall determine the area throughout which such conditions exist, and thereupon issue a notice to the operator of the mine or his agent of such conditions, and

shall file a copy thereof, incorporating his findings therein, with the Secretary and with the representative of the miners of such mine. Upon receipt of such copy, the Secretary shall cause such further investigation to be made as he deems appropriate, including an opportunity for the operator or a representative of the miners to present information relating to such notice.

(2) Upon the conclusion of an investigation pursuant to paragraph (1), and an opportunity for a public hearing upon request by any interested party, the Secretary shall make findings of fact, and shall by decision incorporating such findings therein, either cancel the notice issued under this subsection or issue an order requiring the operator of such mine to cause all persons in the area affected, except those persons referred to in subsection (c) of section 104 to be withdrawn from, and be prohibited from entering, such area until the Secretary, after a public hearing affording all interested persons an opportunity to present their views, determines that such conditions have been abated. Any hearing under this paragraph shall be of record and shall be subject to section 554 of title 5 of the United States Code.

(c) Orders issued pursuant to subsection (a) shall contain a detailed description of the conditions or practices which cause and constitute an imminent danger and a description of the area of the coal or other mine from which persons must be withdrawn and prohibited from entering.

(d) Each finding made and order issued under this section shall be given promptly to the operator of the coal or other mine to which it pertains by the person making such finding or order, and all of such findings and orders shall be in writing, and shall be signed by the person making them. Any order issued pursuant to subsection (a) may be modified or terminated by an authorized representative of the Secretary. Any order issued under subsection (a) or (b) shall remain in effect until vacated, modified, or terminated by the Secretary, or modified or vacated by the Commission pursuant to subsection (e), or by the courts pursuant to section 106(a).

(e)(1) Any operator notified of an order under this section or any representative of miners notified of the issuance, modification, or termination of such an order may apply to the Commission within 30 days of such notification for reinstatement, modification or vacation of such order. The Commission shall forthwith afford an opportunity for a hearing (in accordance with section 554 of title 5, United States Code, but without regard to subsection (a)(3) of such section) and thereafter shall issue an order, based upon findings of fact, vacating, affirming, modifying, or terminating the Secretary's order. The Commission and the courts may not grant temporary relief from the issuance of any order under subsection (a).

(2) The Commission shall take whatever action is necessary to expedite proceedings under this subsection.

INJUNCTIONS

SEC. 108. (a)(1) The Secretary may institute a civil action for relief, including a permanent or temporary injunction, restraining order, or any other appropriate order in the district court of the United States for the district in which a coal or other mine is

located or in which the operator of such mine has his principal office, whenever such operator or his agent--

- (A) violates or fails or refuses to comply with any order or decision issued under this Act,
- (B) interferes with, hinders, or delays the Secretary or his authorized representative, or the Secretary of Health, Education, and Welfare or his authorized representative, in carrying out the provisions of this Act,
- (C) refuses to admit such representatives to the coal or other mine,
- (D) refuses to permit the inspection of the coal or other mine, or the investigation of an accident or occupational disease occurring in, or connected with, such mine,
- (E) refuses to furnish any information or report requested by the Secretary or the Secretary of Health, Education, and Welfare in furtherance of the provisions of this Act, or
- (F) refuses to permit access to, and copying of, such records as the Secretary or the Secretary of Health, Education, and Welfare determines necessary in carrying out the provisions of this Act.

(2) The Secretary may institute a civil action for relief, including permanent or temporary injunction, restraining order, or any other appropriate order in the district court of the United States for the district in which the coal or other mine is located or in which the operator of such mine has his principal office whenever the Secretary believes that the operator of a coal or other mine is engaged in a pattern of violation of the mandatory health or safety standards of this Act, which in the judgment of the Secretary constitutes a continuing hazard to the health or safety of miners.

(b) In any action brought under subsection (a), the court shall have jurisdiction to provide (1) such relief as may be appropriate. In the case of an action under subsection (a)(2), the court shall in its order require such assurance or affirmative steps as it deems necessary to assure itself that the protection afforded to miners under this Act shall be provided by the operator. Temporary restraining orders shall be issued in accordance with rule 65 of the Federal Rules of Civil Procedure, as amended, except that the time limit in such orders, when issued without notice, shall be seven days from the date of entry. Except as otherwise provided herein, any relief granted by the court to enforce any order under paragraph (1) of subsection (a) shall continue in effect until the completion or final termination of all proceedings for review of such order under this title, unless prior thereto, the district court granting such relief sets it aside or modifies it. In any action instituted under this section to enforce an order or decision issued by the Commission or the Secretary after a public hearing in accordance with section 554 of title 5 of the United States Code, the findings of the Commission or the Secretary, as the case may be, if supported by substantial evidence on the record considered as a whole, shall be conclusive.

POSTING OF ORDERS AND DECISIONS

SEC. 109. (a) At each coal or other mine there shall be maintained an office with a conspicuous sign designating it as the office of such mine. There shall be a bulletin board at such office or located at a conspicuous place near an entrance of such mine, in such manner that orders, citations, notices and decisions required by law or regulation to be posted, may be posted thereon, and be easily visible to all persons desiring to read

them, and be protected against damage by weather and against unauthorized removal. A copy of any order, citation, notice or decision required by this Act to be given to an operator shall be delivered to the office of the affected mine, and a copy shall be immediately posted on the bulletin board of such mine by the operator or his agent.

(b) The Secretary shall (1) cause a copy of any order, citation, notice, or decision required by this Act to be given to an operator to be mailed immediately to a representative of the miners in the affected coal or other mine, and (2) cause a copy thereof to be mailed to the public official or agency of the State charged with administering State laws, if any, relating to health or safety in such mine. Such notice, order, citation, or decision shall be available for public inspection.

(c) In order to insure prompt compliance with any notice, order, citation, or decision issued under this Act, the authorized representative of the Secretary may deliver such notice order, citation, or decision to an agent of the operator, and such agent shall immediately take appropriate measures to insure compliance with such notice, order, citation, or decision.

(d) Each operator of a coal or other mine subject to this Act shall file with the Secretary the name and address of such mine and the name and address of the person who controls or operates the mine. Any revisions in such names or addresses shall be promptly filed with the Secretary. Each operator of a coal or other mine subject to this Act shall designate a responsible official at such mine as the principal officer in charge of health and safety at such mine, and such official shall receive a copy of any notice, order, citation, or decision issued under this Act affecting such mine. In any case where the mine is subject to the control of any person not directly involved in the daily operations of the coal or other mine, there shall be filed with the Secretary the name and address of such person and the name and address of a principal official of such person who shall have overall responsibility for the conduct of an effective health and safety program at any coal or other mine subject to the control of such person, and such official shall receive a copy of any notice, order, citation, or decision issued affecting any such mine. The mere designation of a health and safety official under this subsection shall not be construed as making such official subject to any penalty under this Act.

PENALTIES

SEC. 110.(a) The operator of a coal or other mine in which a violation occurs of a mandatory health or safety standard or who violates any other provision of this Act, shall be assessed a civil penalty by the Secretary which penalty shall not be more than \$10,000 [currently \$60,000] for each such violation. Each occurrence of a violation of a mandatory health or safety standard may constitute a separate offense.

(b) Any operator who fails to correct a violation for which a citation has been issued under section 104(a) within the period permitted for its correction may be assessed a civil penalty of not more than \$1,000 [currently \$5,500] for each day during which such failure or violation continues.

(c) Whenever a corporate operator violates a mandatory health or safety standard or knowingly violates or fails or refuses to comply with any order issued under this Act or any order incorporated in a final decision issued under this Act, except an order

incorporated in a decision issued under subsection (a) or section 105(c), any director, officer, or agent of such corporation who knowingly authorized, ordered, or carried out such violation, failure, or refusal shall be subject to the same civil penalties, fines, and imprisonment that may be imposed upon a person under subsections (a) and (d).

(d) Any operator who willfully violates a mandatory health or safety standard, or knowingly violates or fails or refuses to comply with any order issued under section 104 and section 107, or any order incorporated in a final decision issued under this title, except an order incorporated in a decision under subsection (a) or section 105(c), shall, upon conviction, be punished by a fine of not more than \$25,000 or by imprisonment for not more than one year, or by both, except that if the conviction is for a violation committed after the first conviction of such operator under this Act, punishment shall be by a fine of not more than \$50,000, or by imprisonment for not more than five years, or both.

(e) Unless otherwise authorized by this Act, any person who gives advance notice of any inspection to be conducted under this Act shall, upon conviction, be punished by a fine of not more than \$1,000 or by imprisonment for not more than six months, or both.

(f) Whoever knowingly makes any false statement, representation, or certification in any application, record, report, plan, or other document filed or required to be maintained pursuant to this Act shall, upon conviction, be punished by a fine of not more than \$10,000, or by imprisonment for not more than five years, or both.

(g) Any miner who willfully violates the mandatory safety standards relating to smoking or the carrying of smoking materials, matches, or lighters shall be subject to a civil penalty assessed by the Commission, which penalty shall not be more than \$250 [[currently \\$275](#)] for each occurrence of such violation.

(h) Whoever knowingly distributes, sells, offers for sale, introduces, or delivers in commerce any equipment for use in a coal or other mine, including, but not limited to, components and accessories of such equipment, which is represented as complying with the provisions of this Act, or with any specification or regulation of the Secretary applicable to such equipment, and which does not so comply, shall, upon conviction, be subject to the same fine and imprisonment that may be imposed upon a person under subsection (f) of this section.

(i) The Commission shall have authority to assess all civil penalties provided in this Act. In assessing civil monetary penalties, the Commission shall consider the operator's history of previous violations, the appropriateness of such penalty to the size of the business of the operator charged, whether the operator was negligent, the effect on the operator's ability to continue in business, the gravity of the violation, and the demonstrated good faith of the person charged in attempting to achieve rapid compliance after notification of a violation. In proposing civil penalties under this Act, the Secretary may rely upon a summary review of the information available to him and shall not be required to make findings of fact concerning the above factors.

(j) Civil penalties owed under this Act shall be paid to the Secretary for deposit into the Treasury of the United States and shall accrue to the United States and may be recovered in a civil action in the name of the United States brought in the United States

district court for the district where the violation occurred or where the operator has its principal office. Interest at the rate of 8 percent per annum shall be charged against a person on any final order of the Commission, or the court. Interest shall begin to accrue 30 days after the issuance of such order.

(k) No proposed penalty which has been contested before the Commission under section 105(a) shall be compromised, mitigated, or settled except with the approval of the Commission. No penalty assessment which has become a final order of the Commission shall be compromised, mitigated, or settled except with the approval of the court.

(l) The provisions of this section shall not be applicable with respect to title IV of this Act.

Criminal Monetary Fines

Criminal monetary fines are subject to alternative sentencing provisions found at [18 USC 3571](#). Readers should consult that provision in the criminal code for exact legal information. However, that provision in general provides that an individual guilty of any felony or any misdemeanor resulting in death may receive a criminal fine of up to \$250,000 [Reference: 18 USC 3571 (b)]; an organization found guilty of either any felony or a misdemeanor resulting in death may receive a criminal fine of up to \$500,000 [Reference: 18 USC 3571 (c)]. An individual guilty of a misdemeanor not resulting in death is subject to a fine up to \$100,000; an organization found guilty of misdemeanor not resulting in death is subject to a fine of \$200,000 [same references].

Alternate Sentence Provisions

the maximum criminal fine exposure is significantly greater than reflected in the amounts stated in the Mine Act legislation. The Alternative Sentence provisions are found at 18 United States Code section 3571 which provides in pertinent part:

(b) Fines for Individuals: an individual who has been found guilty of an offense may not be fined not more than the greatest of-

- (1) the amount specified in the law setting forth the offense
- (3) for a felony, not more than \$250,000
- (4) for a misdemeanor resulting in death, not more than \$250,000
- (5) for a Class A misdemeanor not resulting in death, not more than \$100,000

(c) Fines for organizations:

- (1) the amount specified in the law setting forth the offense
- (3) for a felony not more than \$500,000
- (4) for a misdemeanor resulting in death, not more than \$500,000
- (5) for a Class A misdemeanor that does not result in death, not more than \$200,000

Class A misdemeanors are misdemeanors subject to maximum imprisonment of less than a year but more than six months. Mine Act misdemeanors are Class A misdemeanors. Any provision which has a maximum term of imprisonment of over one year is a felony.

ENTITLEMENT OF MINERS

SEC. 111. If a coal or other mine or area of such mine is closed by an order issued under section 103, section 104, or section 107, all miners working during the shift when such order was issued who are idled by such order shall be entitled, regardless of the result of any review of such order, to full compensation by the operator at their regular rates of pay for the period they are idled, but for not more than the balance of such shift. If such order is not terminated prior to the next working shift, all miners on that shift who are idled by such order shall be entitled to full compensation by the operator at their regular rates of pay for the period they are idled, but for not more than four hours of such shift. If a coal or other mine or area of such mine is closed by an order issued under section 104 or section 107 of this title for a failure of the operator to comply with any mandatory health or safety standards, all miners who are idled due to such order shall be fully compensated after all interested parties are given an opportunity for a public hearing, which shall be expedited in such cases, and after such order is final, by the operator for lost time at their regular rates of pay for such time as the miners are idled by such closing, or for one week, whichever is the lesser. Whenever an operator violates or fails or refuses to comply with any order issued under section 103, section 104, or section 107 of this Act, all miners employed at the affected mine who would have been withdrawn from, or prevented from entering, such mine or area thereof as a result of such order shall be entitled to full compensation by the operator at their regular rates of pay, in addition to pay received for work performed after such order was issued, for the period beginning when such order was issued and ending when such order is complied with, vacated, or terminated. The Commission shall have authority to order compensation due under this section upon the filing of a complaint by a miner or his representative and after opportunity for hearing subject to section 554 of title 5, United States Code.

MANDATORY HEALTH AND SAFETY TRAINING

SEC. 115. (a) Each operator of a coal or other mine shall have a health and safety training program which shall be approved by the Secretary. The Secretary shall promulgate regulations with respect to such health and safety training programs not more than 180 days after the effective date of the Federal Mine Safety and Health Amendments Act of 1977. Each training program approved by the Secretary shall provide as a minimum that--

- (1) new miners having no underground mining experience shall receive no less than 40 hours of training if they are to work underground. Such training shall include instruction in the statutory rights of miners and their representatives under this Act, use of the self-rescue device and use of respiratory devices, hazard recognition, escapeways, walk around training, emergency procedures, basic ventilation, basic roof control, electrical hazards, first aid, and the health and safety aspects of the task to which he will be assigned;
- (2) new miners having no surface mining experience shall receive no less than 24 hours of training if they are to work on the surface. Such training shall include instruction in the statutory rights of miners and their representatives under this Act, use of the self-rescue device where appropriate and use of respiratory devices where appropriate, hazard recognition, emergency procedures, electrical hazards, first aid, walk around training and the health and safety aspects of the task to

which he will be assigned;

(3) all miners shall receive no less than eight hours of refresher training no less frequently than once each 12 months, except that miners already employed on the effective date of the Federal Mine Safety and Health Amendments Act of 1977 shall receive this refresher training no more than 90 days after the date of approval of the training plan required by this section;

(4) any miner who is reassigned to a new task in which he has had no previous work experience shall receive training in accordance with a training plan approved by the Secretary under this subsection in the safety and health aspects specific to that task prior to performing that task;

(5) any training required by paragraphs (1), (2) or (4) shall include a period of training as closely related as is practicable to the work in which the miner is to be engaged.

(b) Any health and safety training provided under subsection (a) shall be provided during normal working hours. Miners shall be paid at their normal rate of compensation while they take such training, and new miners shall be paid at their starting wage rate when they take the new miner training. If such training shall be given at a location other than the normal place of work, miners shall also be compensated for the additional costs they may incur in attending such training sessions.

(c) Upon completion of each training program, each operator shall certify, on a form approved by the Secretary, that the miner has received the specified training in each subject area of the approved health and safety training plan. A certificate for each miner shall be maintained by the operator, and shall be available for inspection at the mine site, and a copy thereof shall be given to each miner at the completion of such training. When a miner leaves the operator's employ, he shall be entitled to a copy of his health and safety training certificates. False certification by an operator that training was given shall be punishable under section 110(a) and (f); and each health and safety training certificate shall indicate on its face, in bold letters, printed in a conspicuous manner the fact that such false certification is so punishable.

(d) The Secretary shall promulgate appropriate standards for safety and health training for coal or other mine construction workers.

(e) Within 180 days after the effective date of the Federal Mine Safety and Health Amendments Act of 1977, the Secretary shall publish proposed regulations which shall provide that mine rescue teams shall be available for rescue and recovery work to each underground coal or other mine in the event of an emergency. The costs of making advance arrangements for such teams shall be borne by the operator of each such mine.

TITLE III--INTERIM MANDATORY SAFETY STANDARDS FOR UNDERGROUND COAL MINES

ROOF SUPPORT

SEC. 302. (a) Each operator shall undertake to carry out on a continuing basis a program to improve the roof control system of each coal mine and the means and measures to accomplish such system. The roof and ribs of all active underground

roadways, travelways, and working places shall be supported or otherwise controlled adequately to protect persons from falls of the roof or ribs. A roof control plan and revisions thereof suitable to the roof conditions and mining system of each coal mine and approved by the Secretary shall be adopted and set out in printed form within sixty days after the operative date of this title. The plan shall show the type of support and spacing approved by the Secretary. Such plan shall be reviewed periodically, at least every six months by the Secretary, taking into consideration any falls of roof or ribs or inadequacy of support of roof or ribs. No person shall proceed beyond the last permanent support unless adequate temporary support is provided or unless such temporary support is not required under the approved roof control plan and the absence of such support will not pose a hazard to the miners. A copy of the plan shall be furnished the Secretary or his authorized representative and shall be available to the miners and their representatives.

(b) The method of mining followed in any coal mine shall not expose the miner to unusual dangers from roof falls caused by excessive widths of rooms and entries or faulty pillar recovery methods.

(c) The operator, in accordance with the approved plan, shall provide at or near each working face and at such other locations in the coal mine as the Secretary may prescribe an ample supply of suitable materials of proper size with which to secure the roof of all working places in a safe manner. Safety posts, jacks, or other approved devices shall be used to protect the workmen when roof material is being taken down, crossbars are being installed, roof boltholes are being drilled, roof bolts are being installed, and in such other circumstances as may be appropriate. Loose roof and overhanging or loose faces and ribs shall be taken down or supported. Except in the case of recovery work, supports knocked out shall be replaced promptly.

(d) When installation of roof bolts is permitted, such roof bolts shall be tested in accordance with the approved roof control plan.

(e) Roof bolts shall not be recovered where complete extractions of pillars are attempted, where adjacent to clay veins, or at the locations of other irregularities, whether natural or otherwise, that induce abnormal hazards. Where roof bolt recovery is permitted, it shall be conducted only in accordance with methods prescribed in the approved roof control plan, and shall be conducted by experienced miners and only where adequate temporary support is provided.

(f) Where miners are exposed to danger from falls of roof, face, and ribs the operator shall examine and test the roof, face, and ribs before any work or machine is started, and as frequently thereafter as may be necessary to insure safety. When dangerous conditions are found, they shall be corrected immediately.

VENTILATION

SEC. 303. (a) All coal mines shall be ventilated by mechanical ventilation equipment installed and operated in a manner approved by an authorized representative of the Secretary and such equipment shall be examined daily and a record shall be kept of such examination.

(b) All active workings shall be ventilated by a current of air containing not less than 19.5 volume per centum of oxygen, not more than 0.5 volume per centum of carbon dioxide, and no harmful quantities of other noxious or poisonous gases; and the volume and velocity of the current of air shall be sufficient to dilute, render harmless, and to carry away, flammable, explosive, noxious, and harmful gases, and dust, and smoke and explosive fumes. The minimum quantity of air reaching the last open crosscut in any pair or set of developing entries and the last open crosscut in any pair or set of rooms shall be nine thousand cubic feet a minute, and the minimum quantity of air reaching the intake end of a pillar line shall be nine thousand cubic feet a minute. The minimum quantity of air in any coal mine reaching each working face shall be three thousand cubic feet a minute. Within three months after the operative date of this title, the Secretary shall prescribe the minimum velocity and quantity of air reaching each working face of each coal mine in order to render harmless and carry away methane and other explosive gases and to reduce the level of respirable dust to the lowest attainable level. The authorized representative of the Secretary may require in any coal mine a greater quantity and velocity of air when he finds it necessary to protect the health or safety of miners. Within one year after the operative date of this title, the Secretary or his authorized representative shall prescribe the maximum respirable dust level in the intake aircourses in each coal mine in order to reduce such level to the lowest attainable level. In robbing areas of anthracite mines, where the air currents cannot be controlled and measurements of the air cannot be obtained, the air shall have perceptible movement.

(c)(1) Properly installed and adequately maintained line brattice or other approved devices shall be continuously used from the last open crosscut of an entry or room of each working section to provide adequate ventilation to the working faces for the miners and to remove flammable, explosive, and noxious gases, dust, and explosive fumes, unless the Secretary or his authorized representative permits an exception to this requirement, where such exception will not pose a hazard to the miners. When damaged by falls or otherwise, such line brattice or other devices shall be repaired immediately.

(2) The space between the line brattice or other approved device and the rib shall be large enough to permit the flow of a sufficient volume and velocity of air to keep the working face clear of flammable, explosive, and noxious gases, dust, and explosive fumes.

(3) Brattice cloth used underground shall be of flame-resistant material.

(d)(1) Within three hours immediately preceding the beginning of any shift, and before any miner in such shift enters the active workings of a coal mine, certified persons designated by the operator of the mine shall examine such workings and any other underground area of the mine designated by the Secretary or his authorized representative. Each such examiner shall examine every working section in such workings and shall make tests in each such working section for accumulations of methane with means approved by the Secretary for detecting methane and shall make tests for oxygen deficiency with a permissible flame safety lamp or other means approved by the Secretary; examine seals and doors to determine whether they are functioning properly; examine and test the roof, face, and rib conditions in such working section; examine active roadways, travelways, and belt conveyors on which men are carried, approaches to abandoned areas, and accessible falls in such section for hazards; test by means of an anemometer or other device approved by the Secretary to

determine whether the air in each split is traveling in its proper course and in normal volume and velocity: and examine for such other hazards and violations of the mandatory health or safety standards, as an authorized representative of the Secretary may from time to time require. Belt conveyors on which coal is carried shall be examined after each coal-producing shift has begun. Such mine examiner shall place his initials and the date and time at all places he examines. If such mine examiner finds a condition which constitutes a violation of a mandatory health or safety standard or any condition which is hazardous to persons who may enter or be in such area, he shall indicate such hazardous place by posting a "DANGER" sign conspicuously at all points which persons entering such hazardous place would be required to pass, and shall notify the operator of the mine. No person, other than an authorized representative of the Secretary or a State mine inspector or persons authorized by the operator to enter such place for the purpose of eliminating the hazardous condition therein, shall enter such place while such sign is so posted. Upon completing his examination, such mine examiner shall report the results of his examination to a person, designated by the operator to receive such reports at a designated station on the surface of the mine, before other persons enter the underground areas of such mine to work in such shift. Each such mine examiner shall also record the results of his examination with ink or indelible pencil in a book approved by the Secretary kept for such purpose in an area on the surface of the mine chosen by the operator to minimize the danger of destruction by fire or other hazard, and the record shall be open for inspection by interested persons.

(2) No person (other than certified persons designated under this subsection) shall enter any underground area, except during any shift, unless an examination of such area as prescribed in this subsection has been made within eight hours immediately preceding his entrance into such area.

(e) At least once during each coal-producing shift, or more often if necessary for safety, each working section shall be examined for hazardous conditions by certified persons designated by the operator to do so. Any such condition shall be corrected immediately. If such condition creates an imminent danger, the operator shall withdraw all persons from the area affected by such condition to a safe area, except those persons referred to in section 104(d) of this Act, until the danger is abated. Such examination shall include tests for methane with a means approved by the Secretary for detecting methane and for oxygen deficiency with a permissible flame safety lamp or other means approved by the Secretary.

(f) In addition to the pre-shift and daily examinations required by this section, examinations for hazardous conditions, including tests for methane, and for compliance with the mandatory health or safety standards, shall be made at least once each week by a certified person designated by the operator in the return of each split of air where it enters the main return, on pillar falls, at seals, in the main return, at least one entry of each intake and return aircourse in its entirety, idle workings, and, insofar as safety considerations permit, abandoned areas. Such weekly examination need not be made during any week in which the mine is idle for the entire week, except that such examination shall be made before any other miner returns to the mine. The person making such examinations and tests shall place his initials and the date and time at the places examined, and if any hazardous condition is found, such condition shall be reported to the operator promptly. Any hazardous condition shall be corrected immediately. If such condition creates an imminent danger, the operator shall withdraw

all persons from the area affected by such condition to a safe area, except those persons referred to in section 104(d) of this Act, until such danger is abated. A record of these examinations, tests, and actions taken shall be recorded in ink or indelible pencil in a book approved by the Secretary kept for such purpose in an area on the surface of the mine chosen by the mine operator to minimize the danger of destruction by fire or other hazard, and the record shall be open for inspection by interested persons.

(g) At least once each week, a qualified person shall measure the volume of air entering the main intakes and leaving the main returns, the volume passing through the last open crosscut in any pair or set of developing entries and the last open crosscut in any pair or set of rooms, the volume and, when the Secretary so prescribes, the velocity reaching each working face, the volume being delivered to the intake end of each pillar line, and the volume at the intake and return of each split of air. A record of such measurements shall be recorded in ink or indelible pencil in a book approved by the Secretary kept for such purpose in an area on the surface of the coal mine chosen by the operator to minimize the danger of destruction by fire or other hazard, and the record shall be open for inspection by interested persons.

(h)(1) At the start of each shift, tests for methane shall be made at each working place immediately before electrically operated equipment is energized. Such tests shall be made by qualified persons. If 1.0 volume per centum or more of methane is detected, electrical equipment shall not be energized, taken into, or operated in, such working place until the air therein contains less than 1.0 volume per centum of methane. Examinations for methane shall be made during the operation of such equipment at intervals of not more than twenty minutes during each shift, unless more frequent examinations are required by an authorized representative of the Secretary. In conducting such tests, such person shall use means approved by the Secretary for detecting methane.

(2) If at any time the air at any working place, when tested at a point not less than twelve inches from the roof, face, or rib, contains 1.0 volume per centum or more of methane, changes or adjustments shall be made at once in the ventilation in such mine so that such air shall contain less than 1.0 volume per centum of methane. While such changes or adjustments are underway and until they have been achieved, power to electric face equipment located in such place shall be cut off, no other work shall be permitted in such place, and due precautions shall be carried out under the direction of the operator or his agent so as not to endanger other areas of the mine. If at any time such air contains 1.5 volume per centum or more of methane, all persons, except those referred to in section 104(d) of this Act, shall be withdrawn from the area of the mine endangered thereby to a safe area, and all electric power shall be cut off from the endangered area of the mine, until the air in such working place shall contain less than 1.0 volume per centum of methane.

(i)(1) If, when tested, a split of air returning from any working section contains 1.0 volume per centum or more of methane, changes or adjustments shall be made at once in the ventilation in the mine so that such returning air shall contain less than 1.0 volume per centum of methane. Tests under this paragraph and paragraph (2) of this subsection shall be made at four-hour intervals during each shift by a qualified person designated by the operator of the mine. In making such tests, such person shall use means approved by the Secretary for detecting methane.

(2) If, when tested, a split of air returning from any working section contains 1.5 volume per centum or more of methane, all persons, except those persons referred to in section 104(d) of this Act, shall be withdrawn from the area of the mine endangered thereby to a safe area and all electric power shall be cut off from the endangered area of the mine, until the air in such split shall contain less than 1.0 volume per centum of methane.

(3) In virgin territory, if the quantity of air in a split ventilating the active workings in such territory equals or exceeds twice the minimum volume of air prescribed in subsection (b) of this section for the last open crosscut, if the air in the split returning from such workings does not pass over trolley wires or trolley feeder wires, and if a certified person designated by the operator is continually testing the methane content of the air in such split during mining operations in such workings, it shall be necessary to withdraw all persons, except those referred to in section 104(d) of this Act, from the area of the mine endangered thereby to a safe area and all electric power shall be cut off from the endangered area only when the air returning from such workings contains 2.0 volume per centum or more of methane.

(j) Air which has passed by an opening of any abandoned area shall not be used to ventilate any working place in the coal mine if such air contains 0.25 volume per centum or more of methane. Examinations of such air shall be made during the pre-shift examination required by subsection (d) of this section. In making such tests, a certified person designated by the operator shall use means approved by the Secretary for detecting methane. For the purposes of this subsection, an area within a panel shall not be deemed to be abandoned until such panel is abandoned.

(k) Air that has passed through an abandoned area or an area which is inaccessible or unsafe for inspection shall not be used to ventilate any working place in any mine. No air which has been used to ventilate an area from which the pillars have been removed shall be used to ventilate any working place in a mine, except that such air, if it does not contain 0.25 volume per centum or more of methane, may be used to ventilate enough advancing working places immediately adjacent to the line of retreat to maintain an orderly sequence of pillar recovery on a set of entries.

(l) The Secretary or his authorized representative shall require, as an additional device for detecting concentrations of methane, that a methane monitor, approved as reliable by the Secretary after the operative date of this title, be installed, when available, on any electric face cutting equipment, continuous miner, longwall face equipment, and loading machine, except that no monitor shall be required to be installed on any such equipment prior to the date on which such equipment is required to be permissible under section 305(a) of this title. When installed on any such equipment, such monitor shall be kept operative and properly maintained and frequently tested as prescribed by the Secretary. The sensing device of such monitor shall be installed as close to the working face as practicable. Such monitor shall be set to deenergize automatically such equipment when such monitor is not operating properly and to give a warning automatically when the concentration of methane reaches a maximum percentage determined by an authorized representative of the Secretary which shall not be more than 1.0 volume per centum of methane. An authorized representative of the Secretary shall require such monitor to deenergize automatically equipment on which it is installed when the concentration of methane reaches a maximum percentage determined by such representative which shall not be more than 2.0 volume per centum of methane.

(m) Idle and abandoned areas shall be inspected for methane and for oxygen deficiency and other dangerous conditions by a certified person with means approved by the Secretary as soon as possible but not more than three hours before other persons are permitted to enter or work in such areas. Persons, such as pumpmen, who are required regularly to enter such areas in the performance of their duties, and who are trained and qualified in the use of means approved by the Secretary for detecting methane and in the use of a permissible flame safety lamp or other means approved by the Secretary for detecting oxygen deficiency are authorized to make such examinations for themselves, and each such person shall be properly equipped and shall make such examinations upon entering any such area.

(n) Immediately before an intentional roof fail is made, pillar workings shall be examined by a qualified person designated by the operator to ascertain whether methane is present. Such person shall use means approved by the Secretary for detecting methane. If in such examination methane is found in amounts of 1.0 volume per centum or more, such roof fail shall not be made until changes or adjustments are made in the ventilation so that the air shall contain less than 1.0 volume per centum of methane.

(o) A ventilation system and methane and dust control plan and revisions thereof suitable to the conditions and the mining system of the coal mine and approved by the Secretary shall be adopted by the operator and set out in printed form within ninety days after the operative date of this title. The plan shall show the type and location of mechanical ventilation equipment installed and operated in the mine, such additional or improved equipment as the Secretary may require, the quantity and velocity of air reaching each working face, and such other information as the Secretary may require. Such plan shall be reviewed by the operator and the Secretary at least every six months.

(p) Each operator shall provide for the proper maintenance and care of the permissible flame safety lamp or any other approved device for detecting methane and oxygen deficiency by a person trained in such maintenance, and, before each shift, care shall be taken to insure that such lamp or other device is in a permissible condition.

(q) Where areas are being pillared on the operative date of this title without bleeder entries, or without bleeder systems or an equivalent means, pillar recovery may be completed in the area, to the extent approved by an authorized representative of the Secretary, if the edges of pillar lines adjacent to active workings are ventilated with sufficient air to keep the air in open areas along the pillar lines below 1.0 volume per centum of methane.

(r) Each mechanized mining section shall be ventilated with a separate split of intake air directed by overcasts, undercasts, or the equivalent, except an extension of time, not in excess of nine months, may be permitted by the Secretary, under such conditions as he may prescribe, whenever he determines that this subsection cannot be complied with on the operative date of this title.

(s) In all underground areas of a coal mine, immediately before firing each shot or group of multiple shots and after blasting is completed, examinations for methane shall be made by a qualified person with means approved by the Secretary for detecting methane. If methane is found in amounts of 1.0 volume per centum or more, changes or adjustments shall be made at once in the ventilation so that the air shall contain less

than 1.0 volume per centum of methane. No shots shall be fired until the air contains less than 1.0 volume per centum of methane.

(t) Each operator shall adopt a plan within sixty days after the operative date of this title which shall provide that when any mine fan stops, immediate action shall be taken by the operator or his agent (1) to withdraw all persons from the working sections, (2) to cut off the power in the mine in a timely manner, (3) to provide for restoration of power and resumption of work if ventilation is restored within a reasonable period as set forth in the plan after the working places and other active workings where methane is likely to accumulate are reexamined by a certified person to determine if methane in amounts of 1.0 volume per centum or more exists therein, and (4) to provide for withdrawal of all persons from the mine if ventilation cannot be restored within such reasonable time. The plan and revisions thereof approved by the Secretary shall be set out in printed form and a copy shall be furnished to the Secretary or his authorized representative.

(u) Changes in ventilation which materially affect the main air current or any split thereof and which may affect the safety of persons in the coal mine shall be made only when the mine is idle. Only those persons engaged in making such changes shall be permitted in the mine during the change. Power shall be removed from the areas affected by the change before work starts to make the change and shall not be restored until the effect of the change has been ascertained and the affected areas determined to be safe by a certified person.

(v) The mine foreman shall read and countersign promptly the daily reports of the pre-shift examiner and assistant mine foremen, and he shall read and countersign promptly the weekly report covering the examinations for hazardous conditions. Where such reports disclose hazardous conditions, they shall be corrected promptly. If such conditions create an imminent danger, the operator shall withdraw all persons from, or prevent any person from entering, as the case may be, the area affected by such conditions, except those persons referred to in section 104(d) of this Act, until such danger is abated. The mine superintendent or assistant superintendent of the mine shall also read and countersign the daily and weekly reports of such persons.

(w) Each day, the mine foreman and each of his assistants shall enter plainly and sign with ink or indelible pencil in a book approved by the Secretary provided for that purpose a report of the condition of the mine or portion thereof under his supervision, which report shall state clearly the location and nature of any hazardous condition observed by him or reported to him during the day and what action was taken to remedy such condition. Such book shall be kept in an area on the surface of the mine chosen by the operator to minimize the danger of destruction by fire or other hazard, and shall be open for inspection by interested persons.

(x) Before a coal mine is reopened after having been abandoned or declared inactive by the operator, the Secretary shall be notified, and an inspection shall be made of the entire mine by an authorized representative of the Secretary before mining operations commence.

(y)(1) In any coal mine opened after the operative date of this title, the entries used as intake and return aircourses shall be separated from belt haulage entries, and each operator of such mine shall limit the velocity of the air coursed through belt haulage

entries to the amount necessary to provide an adequate supply of oxygen in such entries, and to insure that the air therein shall contain less than 1.0 volume per centum of methane, and such air shall not be used to ventilate active working places. Whenever an authorized representative of the Secretary finds, in the case of any coal mine opened on or prior to the operative date of this title which has been developed with more than two entries, that the conditions in the entries, other than belt haulage entries, are such as to permit adequately the coursing of intake or return air through such entries, (1) the belt haulage entries shall not be used to ventilate, unless such entries are necessary to ventilate, active working places, and (2) when the belt haulage entries are not necessary to ventilate the active working places, the operator of such mine shall limit the velocity of the air coursed through the belt haulage entries to the amount necessary to provide an adequate supply of oxygen in such entries, and to insure that the air therein shall contain less than 1.0 volume per centum of methane.

(2) In any coal mine opened on or after the operative date of this title, or, in the case of a coal mine opened prior to such date, in any new working section of such mine, where trolley haulage systems are maintained and where trolley wires or trolley feeder wires are installed, an authorized representative of the Secretary shall require a sufficient number of entries or rooms as intake aircourses in order to limit, as prescribed by the Secretary, the velocity of air currents on such haulageways for the purpose of minimizing the hazards associated with fires and dust explosions in such haulageways.

(z)(1) While pillars are being extracted in any area of a coal mine, such area shall be ventilated in the manner prescribed by this section.

(2) Within nine months after the operative date of this title, all areas from which pillars have been wholly or partially extracted and abandoned areas, as determined by the Secretary or his authorized representative, shall be ventilated. by bleeder entries or by bleeder systems or equivalent means, or be sealed, as determined by the Secretary or his authorized representative. When ventilation of such areas is required, such ventilation shall be maintained so as continuously to dilute, render harmless, and carry away methane and other explosive gases within such areas and to protect the active workings of the mine from the hazards of such methane and other explosive gases. Air coursed through underground areas from which pillars have been wholly or partially extracted which enters another split of air shall not contain more than 2.0 volume per centum of methane, when tested at the point it enters such other split. When sealing is required, such seals shall be made in an approved manner so as to isolate with explosion-proof bulkheads such areas from the active workings of the mine.

(3) In the case of mines opened on or after the operative date of this title, or in the case of working sections opened on or after such date in mines opened prior to such date, the mining system shall be designed in accordance with a plan and revisions thereof approved by the Secretary and adopted by such operator so that, as each working section of the mine is abandoned, it can be isolated from the active workings of the mine with explosion-proof seals or bulkheads.

COMBUSTIBLE MATERIALS AND ROCK DUSTING

SEC. 304. (a) Coal dust, including float coal dust deposited on rock-dusted surfaces, loose coal, and other combustible materials, shall be cleaned up and not be permitted to accumulate in active workings, or on electric equipment therein.

(b) Where underground mining operations in active workings create or raise excessive amounts of dust, water or water with a wetting agent added to it, or other no less effective methods approved by the Secretary or his authorized representative, shall be used to abate such dust. In working places, particularly in distances less than forty feet from the face, water, with or without a wetting agent, or other no less effective methods approved by the Secretary or his authorized representative, shall be applied to coal dust on the ribs, roof, and floor to reduce dispersibility and to minimize the explosion hazard.

(c) All underground areas of a coal mine, except those areas in which the dust is too wet or too high in incombustible content to propagate an explosion, shall be rock dusted to within forty feet of all working faces, unless such areas are inaccessible or unsafe to enter or unless the Secretary or his authorized representative permits an exception upon his finding that such exception will not pose a hazard to the miners. All crosscuts that are less than forty feet from a working face shall also be rock dusted.

(d) Where rock dust is required to be applied, it shall be distributed upon the top, floor, and sides of all underground areas of a coal mine and maintained in such quantities that the incombustible content of the combined coal dust, rock dust, and other dust shall be not less than 65 per centum, but the incombustible content in the return aircourses shall be no less than 80 per centum. Where methane is present in any ventilating current, the per centum of incombustible content of such combined dusts shall be increased 1.0 and 0.4 per centum for each 0.1 per centum of methane where 65 and 80 per centum, respectively, of incombustibles are required.

(e) Subsections (b) through (d) of this section shall not apply to underground anthracite mines.



Title 30

Code of Federal Regulation

Part 50

30 CFR § 50.2

Definitions.

As used in this part:

(a) *Mine* means: (1) An area of land from which minerals are extracted in nonliquid form or, if in liquid form, are extracted with workers underground (2) private ways and roads appurtenant to such area, and (3) lands, excavations, underground passageways, shafts, slopes, tunnels and workings, structures, facilities, equipment, machines, tools, or other property including impoundments, retention dams, and tailings ponds, on the surface or underground, used in, or to be used in, or resulting from, the work of extracting such minerals from their natural deposits in nonliquid form, or if in liquid form, with workers underground, or used in, or to be used in, the milling of such minerals, or the work of preparing coal or other minerals, and includes custom coal preparation facilities.

(b) *Work of preparing the coal* means the breaking, crushing, sizing, cleaning, washing, drying, mixing, storing, and loading of bituminous coal, lignite, or anthracite, and such other work of preparing such coal as is usually done by the operator of the coal mine.

(c) *Operator* means

(1) Any owner, lessee, or other person who operates, controls, or supervises a coal mine; or,

(2) The person, partnership, association, or corporation, or subsidiary of a corporation operating a metal or nonmetal mine, and owning the right to do so, and includes any agent thereof charged with responsibility for the operation of such mine.

(d) *Miner* means any individual working in a mine.

(e) *Occupational injury* means any injury to a miner which occurs at a mine for which medical treatment is administered, or which results in death or loss of consciousness, inability to perform all job duties on any day after an injury, temporary assignment to other duties, or transfer to another job.

(f) *Occupational illness* means an illness or disease of a miner which may have resulted from work at a mine or for which an award of compensation is made.

(g) *First aid* means one-time treatment, and any follow-up visit for observational purposes, of a minor injury.

(h) *Accident* means

(1) A death of an individual at a mine;

(2) An injury to an individual at a mine which has a reasonable potential to cause death;

(3) An entrapment of an individual for more than 30 minutes or which has a reasonable potential to cause death;

(4) An unplanned inundation of a mine by a liquid or gas;

(5) An unplanned ignition or explosion of gas or dust;

(6) In underground mines, an unplanned fire not extinguished within 10 minutes of discovery; in surface mines and surface areas of underground mines, an unplanned fire not extinguished within 30 minutes of discovery;

(7) An unplanned ignition or explosion of a blasting agent or an explosive;

(8) An unplanned roof fall at or above the anchorage zone in active workings where roof bolts are in use; or, an unplanned roof or rib fall in active workings that impairs ventilation or impedes passage;

(9) A coal or rock outburst that causes withdrawal of miners or which disrupts regular mining activity for more than one hour;

(10) An unstable condition at an impoundment, refuse pile, or culm bank which requires emergency action in order to prevent failure, or which causes individuals to evacuate an area; or, failure of an impoundment, refuse pile, or culm bank;

(11) Damage to hoisting equipment in a shaft or slope which endangers an individual or which interferes with use of the equipment for more than thirty minutes; and

(12) An event at a mine which causes death or bodily injury to an individual not at the mine at the time the event occurs.

30 CFR § 50.10

Immediate notification.

The operator shall immediately contact MSHA at once without delay and within 15 minutes at the toll-free number, 1-800-746-1553, once the operator knows or should know that an accident has occurred involving:

- (a) A death of an individual at the mine;
- (b) An injury of an individual at the mine which has a reasonable potential to cause death;
- (c) An entrapment of an individual at the mine which has a reasonable potential to cause death; or
- (d) Any other accident.

30 CFR § 50.11

Investigation.

(a) After notification of an accident by an operator, the MSHA District Manager will promptly decide whether to conduct an accident investigation and will promptly inform the operator of his decision. If MSHA decides to investigate an accident, it will initiate the investigation within 24 hours of notification.

(b) Each operator of a mine shall investigate each accident and each occupational injury at the mine. Each operator of a mine shall develop a report of each investigation. No operator may use Form 7000-1 as a report, except that an operator of a mine at which fewer than twenty miners are employed may, with respect to that mine, use Form 7000-1 as an investigation report respecting an occupational injury not related to an accident. No operator may use an investigation or an investigation report conducted or prepared by MSHA to comply with this paragraph. An operator shall submit a copy of any investigation report to MSHA at its request. Each report prepared by the operator shall include,

- (1) The date and hour of occurrence;
- (2) The date the investigation began;
- (3) The names of individuals participating in the investigation;
- (4) A description of the site;
- (5) An explanation of the accident or injury, including a description of any equipment involved and relevant events before and after the occurrence, and any explanation of the cause of any injury, the cause of any accident or cause of any other event which caused an injury;
- (6) The name, occupation, and experience of any miner involved;
- (7) A sketch, where pertinent, including dimensions depicting the occurrence;

- (8) A description of steps taken to prevent a similar occurrence in the future; and
- (9) Identification of any report submitted under §50.20 of this part.

30 CFR § 50.12

Preservation of evidence.

Unless granted permission by a MSHA District Manager, no operator may alter an accident site or an accident related area until completion of all investigations pertaining to the accident except to the extent necessary to rescue or recover an individual, prevent or eliminate an imminent danger, or prevent destruction of mining equipment.

30 CFR § 50.20

Preparation and submission of MSHA Report Form 7000-1--Mine Accident, Injury, and Illness Report.

(a) Each operator shall maintain at the mine office a supply of MSHA Mine Accident, Injury, and Illness Report [Form 7000-1](#). These may be obtained from the MSHA District Office. Each operator shall report each accident, occupational injury, or occupational illness at the mine. The principal officer in charge of health and safety at the mine or the supervisor of the mine area in which an accident or occupational injury occurs, or an occupational illness may have originated, shall complete or review the form in accordance with the instructions and criteria in [§§50.20-1](#) through 50.20-7. If an occupational illness is diagnosed as being one of those listed in [§50.20-6\(b\)\(7\)](#), the operator must report it under this part. The operator shall mail completed forms to MSHA within ten working days after an accident or occupational injury occurs or an occupational illness is diagnosed. When an accident specified in [§50.10](#) occurs, which does not involve an occupational injury, sections A, B, and items 5 through 12 of section C of Form 7000-1 shall be completed and mailed to MSHA in accordance with the instructions in [§50.20-1](#) and criteria contained in [§§50.20-4](#) through 50.20-6.

(b) Each operator shall report each occupational injury or occupational illness on one set of forms. If more than one miner is injured in the same accident or is affected simultaneously with the same occupational illness, an operator shall complete a separate set of forms for each miner affected. To the extent that the form is not self-explanatory, an operator shall complete the form in accordance with the instructions in [§50.20-1](#) and criteria contained in [§§50.20-2](#) through 50.20-7.

30 CFR § 50.20-1

General instructions for completing MSHA Form 7000-1.

Each Form 7000-1 consists of four sheets, an original and three copies. The original form shall be mailed to: MSHA Office of Injury and Employment Information, P.O. Box 25367, Denver Federal Center, Denver, Colo. 80225, within ten working days after an accident, occupational injury or occupational illness. At the same time, the first copy shall be mailed to the appropriate local MSHA district. If the first copy does

not contain a completed Section D--Return to Duty Information--the second copy shall be retained by the operator until the miner returns to work or a final disposition is made respecting the miner. When the miner returns to work or a final disposition is made, the operator shall, within five days, complete Section D and mail the second copy to the MSHA Office of Injury and Employment Information. A third copy, containing all the information in the first and second copies shall be retained at the mine office closest to the mine for a period of five years.

You may also submit reports by facsimile, 888-231-5515. To [file electronically](#), follow the instructions on the MSHA Internet site, <http://www.msha.gov>. For assistance in electronic filing, contact the MSHA help desk at 877-778- 6055.

30 CFR § 50.40
Maintenance of records.

(a) Each operator of a mine shall maintain a copy of each investigation report required to be prepared under [§50.11](#) at the mine office closest to the mine for five years after the concurrence.

(b) Each operator shall maintain a copy of each report submitted under [§50.20](#) or [§50.30](#) at the mine office closest to the mine for five years after submission. Upon request by the Mine Safety and Health Administration, an operator shall make a copy of any report submitted under [§50.20](#) or [§50.30](#) available to MSHA for inspection or copying.

30 CFR § 50.41
Verification of reports.

Upon request by MSHA, an operator shall allow MSHA to inspect and copy information related to an accident, injury or illnesses which MSHA considers relevant and necessary to verify a report of investigation required by [§50.11](#) of this part or relevant and necessary to a determination of compliance with the reporting requirements of this part.



Title 30

Code of Federal Regulation

Part 75

30 CFR § 75.100 **Certified person.**

(a) The provisions of Subpart D--Ventilation of this [Part 75](#) require that certain examinations and tests be made by a certified person. A certified person within the meaning of those provisions is a person who has been certified as a mine foreman (mine manager), an assistant mine foreman (section foreman), or a preshift examiner (mine examiner). A person who has been so certified is also a qualified person within the meaning of those provisions of Subpart D of this part which require that certain tests be made by a qualified person and within the meaning of [§75.1106](#).

(b) A person who is certified as a mine foreman, an assistant mine foreman, or a preshift examiner by the State in which the coal mine is located is, to the extent of the State's certification, a certified person within the meaning of the provisions of Subpart D of this part and [§75.1106](#) referred to in paragraph (a) of this section.

(c)(1) The Secretary may certify persons in the categories of mine foreman, assistant mine foreman, and preshift examiner whenever the State in which persons are presently employed in these categories does not provide for such certification. A person's initial certification by MSHA is valid for as long as the person continues to satisfy the requirements necessary to obtain the certification and is employed at the same coal mine or by the same independent contractor. The mine operator or independent contractor shall make an application which satisfactorily shows that each such person has had at least 2 years underground experience in a coal mine, and has held the position of mine foreman, assistant mine foreman, or preshift examiner for a period of 6 months immediately preceding the filing of the application, and is qualified to test for methane and for oxygen deficiency. Applications for Secretarial certification should be submitted in writing to the Health and Safety Activity, Mine Safety and Health Administration, Certification and Qualification Center, P.O. Box 25367, Denver Federal Center, Denver, Colorado 80225.

(2) A person certified by the Secretary under this paragraph will be a certified person, within the meaning of the provisions for Subpart D of this part and [35 FR 17890, Nov. 20, 1970, as amended at 43 FR 12320, Mar. 24, 1978; 54 FR 30514, July 20, 1989]

30 CFR § 75.150

Tests for methane and for oxygen deficiency; qualified person.

- (a) The provisions of Subpart D--Ventilation of this part and [§75.1106](#) require that tests for methane and for oxygen deficiency be made by a qualified person. A person is a qualified person for this purpose if he is a certified person under [§75.100](#).
- (b) Pending issuance of Federal standards, a person will be considered a qualified person for testing for methane and for oxygen deficiency:
- (1) If he has been qualified for this purpose by the State in which the coal mine is located; or
- (2) The Secretary may qualify persons for this purpose in a coal mine in which persons are not qualified for this purpose by the State upon an application and a satisfactory showing by the operator of the coal mine that each such person has been trained and designated by the operator to test for methane and oxygen deficiency and has made such tests for a period of 6 months immediately preceding the application. Applications for Secretarial qualification should be submitted to the Health and Safety Activity, Mine Safety and Health Administration, Certification and Qualification Center, P.O. Box 25367, Denver Federal Center, Denver, Colo. 80225.

30 CFR § 75.204

Roof bolting.

- (a) For roof bolts and accessories addressed in ASTM F432-95, "Standard Specification for Roof and Rock Bolts and Accessories," the mine operator shall--
- (1) Obtain a manufacturer's certification that the material was manufactured and tested in accordance with the specifications of ASTM F432-95; and
- (2) Make this certification available to an authorized representative of the Secretary and to the representative of miners.
- (b) Roof bolts and accessories not addressed in ASTM F432-95 may be used, provided that the use of such materials is approved by the District Manager based on
- (1) Demonstrations which show that the materials have successfully supported the roof in an area of a coal mine with similar strata, opening dimensions and roof stresses; or
- (2) Tests which show the materials to be effective for supporting the roof in an area of the affected mine which has similar strata, opening dimensions and roof stresses as the area where the roof bolts are to be used. During the test process, access to the test area shall be limited to persons necessary to conduct the test.
- (c)(1) A bearing plate shall be firmly installed with each roof bolt.
- (2) Bearing plates used directly against the mine roof shall be at least 6 inches square or the equivalent, except that where the mine roof is firm and not susceptible to sloughing, bearing plates 5 inches square or the equivalent may be used.

(3) Bearing plates used with wood or metal materials shall be at least 4 inches square or the equivalent.

(4) Wooden materials that are used between a bearing plate and the mine roof in areas which will exist for three years or more shall be treated to minimize deterioration.

(d) When washers are used with roof bolts, the washers shall conform to the shape of the roof bolt head and bearing plate.

(e)(1) The diameter of finishing bits shall be within a tolerance of plus or minus 0.030 inch of the manufacturer's recommended hole diameter for the anchor used.

(2) When separate finishing bits are used, they shall be distinguishable from other bits.

(f) *Tensioned roof bolts.* (1) Roof bolts that provide support by creating a beam of laminated strata shall be at least 30 inches long. Roof bolts that provide support by suspending the roof from overlying stronger strata shall be long enough to anchor at least 12 inches into the stronger strata.

(2) Test holes, spaced at intervals specified in the roof control plan, shall be drilled to a depth of at least 12 inches above the anchorage horizon of mechanically anchored tensioned bolts being used. When a test hole indicates that bolts would not anchor in competent strata, corrective action shall be taken.

(3) The installed torque or tension ranges for roof bolts as specified in the roof control plan shall maintain the integrity of the support system and shall not exceed the yield point of the roof bolt nor anchorage capacity of the strata.

(4) In each roof bolting cycle, the actual torque or tension of the first tensioned roof bolt installed with each drill head shall be measured immediately after it is installed. Thereafter, for each drill head used, at least one roof bolt out of every four installed shall be measured for actual torque or tension. If the torque or tension of any of the roof bolts measured is not within the range specified in the roof control plan, corrective action shall be taken.

(5) In working places from which coal is produced during any portion of a 24-hour period, the actual torque or tension on at least one out of every ten previously installed mechanically anchored tensioned roof bolts shall be measured from the outby corner of the last open crosscut to the face in each advancing section. Corrective action shall be taken if the majority of the bolts measured--

(f) (5) (i) Do not maintain at least 70 percent of the minimum torque or tension specified in the roof control plan, 50 percent if the roof bolt plates bear against wood; or

(f) (5) (ii) Have exceeded the maximum specified torque or tension by 50 percent.

(6) The mine operator or a person designated by the operator shall certify by signature and date that measurements required by paragraph (f)(5) of this section have been made. This certification shall be maintained for at least one year and shall be made available to an authorized representative of the Secretary and representatives of the

miners.

(7) Tensioned roof bolts installed in the roof support pattern shall not be used to anchor trailing cables or used for any other purpose that could affect the tension of the bolt. Hanging trailing cables, line brattice, telephone lines, or other similar devices which do not place sudden loads on the bolts are permitted.

(8) Angle compensating devices shall be used to compensate for the angle when tensioned roof bolts are installed at angles greater than 5 degrees from the perpendicular to the bearing plate.

(g) *Non-tensioned grouted roof bolts.* The first non-tensioned grouted roof bolt installed during each roof bolting cycle shall be tested during or immediately after the first row of bolts has been installed. If the bolt tested does not withstand at least 150 foot-pounds of torque without rotating in the hole, corrective action shall be taken.

30 CFR § 75.205

Installation of roof support using mining machines with integral roof bolters.

When roof bolts are installed by a continuous mining machine with integral roof bolting equipment:

(a) The distance between roof bolts shall not exceed 10 feet crosswise.

(b) Roof bolts to be installed 9 feet or more apart shall be installed with a wooden crossbar at least 3 inches thick and 8 inches wide, or material which provides equivalent support.

(c) Roof bolts to be installed more than 8 feet but less than 9 feet apart shall be installed with a wooden plank at least 2 inches thick and 8 inches wide, or material which provides equivalent support.

30 CFR § 75.206

Conventional roof support.

(a) Except in anthracite mines using non-mechanized mining systems, when conventional roof support materials are used as the only means of support--

(1) The width of any opening shall not exceed 20 feet;

(2) The spacing of roadway roof support shall not exceed 5 feet;

(3)(i) Supports shall be installed to within 5 feet of the uncut face;

(a)(3)(ii) When supports nearest the face must be removed to facilitate the operation of face equipment, equivalent temporary support shall be installed prior to removing the supports;

(4) Straight roadways shall not exceed 16 feet wide where full overhead support is used and 14 feet wide where only posts are used;

(5) Curved roadways shall not exceed 16 feet wide; and

(6) The roof at the entrance of all openings along travelways which are no longer needed for storing supplies or for travel of equipment shall be supported by extending the line of support across the opening.

(b) Conventional roof support materials shall meet the following specifications:

(1) The minimum diameter of cross-sectional area of wooden posts shall be as follows:

Post length (in inches)	Diameter of round posts (in inches)	Cross-sectional area of split posts (in square inches)
60 or less.....	4	13
Over 60 to 84.....	5	20
Over 84 to 108.....	6	28
Over 108 to 132.....	7	39
Over 132 to 156.....	8	50
Over 156 to 180.....	9	64
Over 180 to 204.....	10	79
Over 204 to 228.....	11	95
Over 228.....	12	113

(2) Wooden materials used for support shall have the following dimensions:

(b) (2)(i) Cap blocks and footings shall have flat sides and be at least 2 inches thick, 4 inches wide and 12 inches long.

(b) (2)(ii) Crossbars shall have a minimum cross-sectional area of 24 square inches and be at least 3 inches thick.

(b) (2)(iii) Planks shall be at least 6 inches wide and 1 inch thick.

(3) Cribbing materials shall have at least two parallel flat sides.

(c) A cluster of two or more posts that provide equivalent strength may be used to meet the requirements of paragraph (b)(1) of this section, except that no post shall have a diameter less than 4 inches or have a cross-sectional area less than 13 square inches.

(d) Materials other than wood used for support shall have support strength at least equivalent to wooden material meeting the applicable provisions of this section.

(e) Posts and jacks shall be tightly installed on solid footing.

(f) When posts are installed under roof susceptible to sloughing a cap block, plank, crossbar or materials that are equally effective shall be placed between the post and the roof.

(g) Blocks used for lagging between the roof and crossbars shall be spaced to distribute the load.

(h) Jacks used for roof support shall be used with at least 36 square inches of roof bearing surface.

30 CFR § 75.207

Pillar recovery.

Pillar recovery shall be conducted in the following manner, unless otherwise specified in the roof control plan:

(a) Full and partial pillar recovery shall not be conducted on the same pillar line, except where physical conditions such as unstable floor or roof, falls of roof, oil and gas well barriers or surface subsidence require that pillars be left in place.

(b) Before mining is started in a pillar split or lift--

(1) At least two rows of breaker posts or equivalent support shall be installed--

(b)(1)(i) As close to the initial intended breakline as practicable; and

(b)(1)(ii) Across each opening leading into an area where full or partial pillar extraction has been completed.

(2) A row of roadside-radius (turn) posts or equivalent support shall be installed leading into the split or lift.

(c) Before mining is started on a final stump--

(1) At least 2 rows of posts or equivalent support shall be installed on not more than 4-foot centers on each side of the roadway; and

(2) Only one open roadway, which shall not exceed 16 feet wide, shall lead from solid pillars to the final stump of a pillar. Where posts are used as the sole means of roof support, the width of the roadway shall not exceed 14 feet.

(d) During open-end pillar extraction, at least 2 rows of breaker posts or equivalent support shall be installed on not more than 4-foot centers. These supports shall be installed between the lift to be started and the area where pillars have been extracted. These supports shall be maintained to within 7 feet of the face and the width of the roadway shall not exceed 16 feet. Where posts are used as the sole means of roof support, the width of the roadway shall not exceed 14 feet.

30 CFR § 75.208
Warning devices.

Except during the installation of roof supports, the end of permanent roof support shall be posted with a readily visible warning, or a physical barrier shall be installed to impede travel beyond permanent support.

30 CFR § 75.210
Manual installation of temporary support.

(a) When manually installing temporary support, only persons engaged in installing the support shall proceed beyond permanent support.

(b) When manually installing temporary supports, the first temporary support shall be set no more than 5 feet from a permanent roof support and the rib. All temporary supports shall be set so that the person installing the supports remains between the temporary support being set and two other supports which shall be no more than 5 feet from the support being installed. Each temporary support shall be completely installed prior to installing the next temporary support.

(c) All temporary supports shall be placed on no more than 5-foot centers.

(d) Once temporary supports have been installed, work or travel beyond permanent roof support shall be done between temporary supports and the nearest permanent support or between other temporary supports.

30 CFR § 75.211
Roof testing and scaling.

(a) A visual examination of the roof, face and ribs shall be made immediately before any work is started in an area and thereafter as conditions warrant.

(b) Where the mining height permits and the visual examination does not disclose a hazardous condition, sound and vibration roof tests, or other equivalent tests, shall be made where supports are to be installed. When sound and vibration tests are made, they shall be conducted--

(1) After the ATRS system is set against the roof and before other support is installed; or

(2) Prior to manually installing a roof support. This test shall begin under supported roof and progress no further than the location where the next support is to be installed.

(c) When a hazardous roof, face, or rib condition is detected, the condition shall be corrected before there is any other work or travel in the affected area. If the affected area is left unattended, each entrance to the area shall be posted with a readily visible warning, or a physical barrier shall be installed to impede travel into the area.

(d) A bar for taking down loose material shall be available in the working place or on all face equipment except haulage equipment. Bars provided for taking down loose material shall be of a length and design that will allow the removal of loose material from a

position that will not expose the person performing this work to injury from falling material.

30 CFR § 75.212

Rehabilitation of areas with unsupported roof.

(a) Before rehabilitating each area where a roof fall has occurred or the roof has been removed by mining machines or by blasting--

(1) The mine operator shall establish the clean up and support procedures that will be followed;

(2) All persons assigned to perform rehabilitation work shall be instructed in the clean-up and support procedures; and

(3) Ineffective, damaged or missing roof support at the edge of the area to be rehabilitated shall be replaced or other equivalent support installed.

(b) All persons who perform rehabilitation work shall be experienced in this work or they shall be supervised by a person experienced in rehabilitation work who is designated by the mine operator.

(c) Where work is not being performed to rehabilitate an area in active workings where a roof fall has occurred or the roof has been removed by mining machines or by blasting, each entrance to the area shall be supported by at least one row of posts on not more than 5-foot centers, or equally effective support.

30 CFR § 75.213

Roof support removal.

(a)(1) All persons who perform the work of removing permanent roof supports shall be supervised by a management person experienced in removing roof supports.

(2) Only persons with at least one year of underground mining experience shall perform permanent roof support removal work.

(b) Prior to the removal of permanent roof supports, the person supervising roof support removal in accordance with paragraph (a)(1) of this section shall examine the roof conditions in the area where the supports are to be removed and designate each support to be removed.

(c)(1) Except as provided in paragraph (g) of this section, prior to the removal of permanent supports, a row of temporary supports on no more than 5-foot centers or equivalent support shall be installed across the opening within 4 feet of the supports being removed. Additional supports shall be installed where necessary to assure safe removal.

(2) Prior to the removal of roof bolts, temporary support shall be installed as close as practicable to each roof bolt being removed.

(d) Temporary supports installed in accordance with this section shall not be removed unless--

(1) Removal is done by persons who are in a remote location under supported roof; and

(2) At least two rows of temporary supports, set across the opening on no more than 5-foot centers, are maintained between the miners and the unsupported area.

(e) Each entrance to an area where supports have been removed shall be posted with a readily visible warning or a physical barrier shall be installed to impede travel into the area.

(f) Except as provided in paragraph (g) of this section, permanent support shall not be removed where--

(1) Roof bolt torque or tension measurements or the condition of conventional support indicate excessive loading;

(2) Roof fractures are present;

(3) There is any other indication that the roof is structurally weak; or

(4) Pillar recovery has been conducted.

(g) Permanent supports may be removed provided that:

(1) Removal is done by persons who are in a remote location under supported roof; and

(2) At least two rows of temporary supports, set across the opening on no more than 5-foot centers, are maintained between the miners and the unsupported area.

(h) The provisions of this section do not apply to removal of conventional supports for starting crosscuts and pillar splits or lifts except that prior to the removal of these supports an examination of the roof conditions shall be made.

30 CFR § 75.214

Supplemental support materials, equipment and tools.

(a) A supply of supplementary roof support materials and the tools and equipment necessary to install the materials shall be available at a readily accessible location on each working section or within four crosscuts of each working section.

(b) The quantity of support materials and tools and equipment maintained available in accordance with this section shall be sufficient to support the roof if adverse roof conditions are encountered, or in the event of an accident involving a fall.

30 CFR § 75.215

Longwall mining systems.

For each longwall mining section, the roof control plan shall specify--

- (a) The methods that will be used to maintain a safe travelway out of the section through the tailgate side of the longwall; and
- (b) The procedures that will be followed if a ground failure prevents travel out of the section through the tailgate side of the longwall.

30 CFR § 75.222

Roof control plan-approval criteria.

(a) This section sets forth the criteria that shall be considered on a mine-by-mine basis in the formulation and approval of roof control plans and revisions. Additional measures may be required in plans by the District Manager. Roof control plans that do not conform to the applicable criteria in this section may be approved by the District Manager, provided that effective control of the roof, face and ribs can be maintained.

(b) *Roof Bolting.* (1) Roof bolts should be installed on centers not exceeding 5 feet lengthwise and crosswise, except as specified in [§75.205](#).

(2) When tensioned roof bolts are used as a means of roof support, the torque or tension range should be capable of supporting roof bolt loads of at least 50 percent of either the yield point of the bolt or anchorage capacity of the strata, whichever is less.

(3) Any opening that is more than 20 feet wide should be supported by a combination of roof bolts and conventional supports.

(4) In any opening more than 20 feet wide--

(b) (4) (i) Posts should be installed to limit each roadway to 16 feet wide where straight and 18 feet wide where curved; and

(b) (4) (ii) A row of posts should be set for each 5 feet of space between the roadway posts and the ribs.

(5) Openings should not be more than 30 feet wide.

(c) *Installation of roof support using mining machines with integral roof bolters.* (1) Before an intersection or pillar split is started, roof bolts should be installed on at least 5-foot centers where the work is performed.

(2) Where the roof is supported by only two roof bolts crosswise, openings should not be more than 16 feet wide.

(d) *Pillar recovery.* (1) During development, any dimension of a pillar should be at least 20 feet.

(2) Pillar splits and lifts should not be more than 20 feet wide.

(3) Breaker posts should be installed on not more than 4-foot centers.

(4) Roadside-radius (turn) posts, or equivalent support, should be installed on not more than 4-foot centers leading into each pillar split or lift.

(5) Before full pillar recovery is started in areas where roof bolts are used as the only means of roof support and openings are more than 16 feet wide, at least one row of posts should be installed to limit the roadway width to 16 feet. These posts should be--

(d)(5)(i) Extended from the entrance to the split through the intersection outby the pillar in which the split or lift is being made; and

(d)(5)(ii) Spaced on not more than 5-foot centers.

(e) *Unsupported openings at intersections.* Openings that create an intersection should be permanently supported or at least one row of temporary supports should be installed on not more than 5-foot centers across the opening before any other work or travel in the intersection.

(f) *ATRS systems in working sections where the mining height is below 30 inches.* In working sections where the mining height is below 30 inches, an ATRS system should be used to the extent practicable during the installation of roof bolts with roof bolting machines and continuous-mining machines with integral roof bolters.

(g) *Longwall mining systems.* (1) Systematic supplemental support should be installed throughout--

(g)(1)(i) The tailgate entry of the first longwall panel prior to any mining; and

(g)(1)(ii) In the proposed tailgate entry of each subsequent panel in advance of the frontal abutment stresses of the panel being mined.

(2) When a ground failure prevents travel out of the section through the tailgate side of the longwall section, the roof control plan should address--

(g)(2)(i) Notification of miners that the travelway is blocked;

(g)(2)(ii) Re-instruction of miners regarding escapeways and escape procedures in the event of an emergency;

(g)(2)(iii) Re-instruction of miners on the availability and use of self-contained self-rescue devices;

(g)(2)(iv) Monitoring and evaluation of the air entering the longwall section;

(g)(2)(v) Location and effectiveness of the two-way communication systems; and

(g)(2)(vi) A means of transportation from the section to the main line.

(3) The plan provisions addressed by paragraph (g)(2) of this section should remain in effect until a travelway is reestablished on the tailgate side of a longwall section.

30 CFR § 75.223

Evaluation and revision of roof control plan.

(a) Revisions of the roof control plan shall be proposed by the operator--

(1) When conditions indicate that the plan is not suitable for controlling the roof, face, ribs, or coal or rock bursts; or

(2) When accident and injury experience at the mine indicates the plan is inadequate. The accident and injury experience at each mine shall be reviewed at least every six months.

(b) Each unplanned roof fall and rib fall and coal or rock burst that occurs in the active workings shall be plotted on a mine map if it--

(1) Is above the anchorage zone where roof bolts are used;

(2) Impairs ventilation;

(3) Impedes passage of persons;

(4) Causes miners to be withdrawn from the area affected; or

(5) Disrupts regular mining activities for more than one hour.

(c) The mine map on which roof falls are plotted shall be available at the mine site for inspection by authorized representatives of the Secretary and representatives of miners at the mine.

(d) The roof control plan for each mine shall be reviewed every six months by an authorized representative of the Secretary. This review shall take into consideration any falls of the roof, face and ribs and the adequacy of the support systems used at the time.

30 CFR § 75.1100-2

Quantity and location of firefighting equipment.

(a) *Working sections.*

(1) Each working section of coal mines producing 300 tons or more per shift shall be provided with two portable fire extinguishers and 240 pounds of rock dust in bags or other suitable containers; waterlines shall extend to each section loading point and be equipped with enough fire hose to reach each working face unless the section loading point is provided with one of the following:

(i) Two portable water cars; or

(ii) Two portable chemical cars; or

(iii) One portable water car or one portable chemical car, and either (a) a portable foam-generating machine or (b) a portable high-pressure rock-dusting machine fitted with at least 250 feet of hose and supplied with at least 60 sacks of rock dust.

(2) Each working section of coal mines producing less than 300 tons of coal per shift shall be provided with the following:

(i) Two portable fire extinguishers; and

(ii) 240 pounds of rock dust in bags or other suitable containers; and

(iii) At least 500 gallons of water and at least three pails of 10- quart capacity; or a waterline with sufficient hose to reach the working places; or a portable water car of at least 500-gallons capacity; or a portable, all-purpose, dry-powder chemical car of at least 125-pounds capacity.

(3) As an alternative to paragraph (a)(2) of this section, each working section with no electrical equipment at the face of an anthracite coal mine producing less than 300 tons of coal per shift shall be provided with the following:

(i) Portable fire extinguishers containing a total capacity of at least 30 pounds of dry chemical or 15 gallons of foam and located at the entrance to the gangway at the bottom of the slope; and

(ii) Portable fire extinguishers containing a total capacity of at least 20 pounds of dry chemical or 10 gallons of foam and located within 500 feet from the working face.

(b) *Belt conveyors.* In all coal mines, waterlines shall be installed parallel to the entire length of belt conveyors and shall be equipped with firehose outlets with valves at 300-foot intervals along each belt conveyor and at tailpieces. At least 500 feet of firehose with fittings suitable for connection with each belt conveyor waterline system shall be stored at strategic locations along the belt conveyor. Waterlines may be installed in entries adjacent to the conveyor entry belt as long as the outlets project into the belt conveyor entry.

(c) *Haulage tracks.* (1) In mines producing 300 tons of coal or more per shift waterlines shall be installed parallel to all haulage tracks using mechanized equipment in the track or adjacent entry and shall extend to the loading point of each working section. Waterlines shall be equipped with outlet valves at intervals of not more than 500 feet, and 500 feet of firehose with fittings suitable for connection with such waterlines shall be provided at strategic locations. Two portable water cars, readily available, may be used in lieu of waterlines prescribed under this paragraph.

(2) In mines producing less than 300 tons of coal per shift, there shall be provided at 500-foot intervals in all main and secondary haulage roads:

(i) A tank of water of at least 55-gallon capacity with at least 3 pails of not less than 10-quart capacity; or

(ii) Not less than 240 pounds of bagged rock dust. (d) *Transportation.* Each track or

off-track locomotive, self-propelled man-trip car, or personnel carrier shall be equipped with one portable fire extinguisher.

(e) *Electrical installations.* At each electrical installation, the operator shall provide two portable fire extinguishers that have a nominal capacity of 5 pounds of dry chemical, or one extinguisher that has a nominal capacity of at least 10 pounds of dry chemical, and which have a 2-A:10-B:C or higher rating.

(2) One portable fire extinguisher and 240 pounds of rock dust shall be provided at each temporary electrical installation.

(f) *Oil storage stations.* Two portable fire extinguishers and 240 pounds of rock dust, shall be provided at each permanent underground oil storage station. One portable fire extinguisher shall be provided at each working section where 25 gallons or more of oil are stored in addition to extinguishers required under paragraph (a) of this section.

(g) *Welding, cutting, soldering.* One portable fire extinguisher or 240 pounds of rock dust shall be provided at locations where welding, cutting, or soldering with arc or flame is being done.

(h) *Powerlines.* At each wooden door through which powerlines pass there shall be one portable fire extinguisher or 240 pounds of rock dust within 25 feet of the door on the intake air side.

(i) *Emergency materials.*

(1) At each mine producing 300 tons of coal or more per shift there shall be readily available the following materials at locations not exceeding 2 miles from each working section:

1,000 board feet of brattice boards

2 rolls of brattice cloth

2 hand saws

25 pounds of 8(super)d nails

25 pounds of 10(super)d nails

25 pounds of 16(super)d nails

3 claw hammers

25 bags of wood fiber plaster or 10 bags of cement (or equivalent material for stoppings)

5 tons of rock dust

(2) At each mine producing less than 300 tons of coal per shift the above materials

shall be available at the mine, provided, however, that the emergency materials for one or more mines may be stored at a central warehouse or building supply company and such supply must be the equivalent of that required for all mines involved and within 1-hour's delivery time from each mine. This exception shall not apply where the active working sections are more than 2 miles from the surface.

30 CFR § 75.1100-3

Condition and examination of firefighting equipment.

All firefighting equipment shall be maintained in a usable and operative condition. Chemical extinguishers shall be examined every 6 months and the date of the examination shall be written on a permanent tag attached to the extinguisher.

30 CFR § 75.1106-2

Transportation of liquefied and nonliquefied compressed gas cylinders; requirements.

TRANSPORTATION, HANDLING AND STORAGE OF LIQUEFIED AND NONLIQUEFIED COMPRESSED GAS CYLINDERS

(a) Liquefied and nonliquefied compressed gas cylinders transported into or through an underground coal mine shall be:

(1) Placed securely in devices designed to hold the cylinder in place during transit on self-propelled equipment or belt conveyors;

(2) Disconnected from all hoses and gages;

(3) Equipped with a metal cap or "headband" (fence-type metal protector around the valve stem) to protect the cylinder valve during transit; and,

(4) Clearly labeled "empty" or "MT" when the gas in the cylinder has been expended.

(b) In addition to the requirements of paragraph (a) of this section, when liquefied and nonliquefied compressed gas cylinders are transported by a trolley wire haulage system into or through an underground coal mine, such cylinders shall be placed in well insulated and substantially constructed containers which are specifically designed for holding such cylinders.

(c) Liquefied and nonliquefied compressed gas cylinders shall not be transported on mantrips.

30 CFR § 75.1202-1

Temporary notations, revisions, and supplements.

(a) Mine maps shall be revised and supplemented at intervals of not more than 6 months.

(b) Temporary notations shall include:

- (1) The location of each working face of each working place;
- (2) Pillars mined or other such second mining;
- (3) Permanent ventilation controls constructed or removed, such as seals, overcasts, undercasts, regulators, and permanent stoppings, and the direction of air currents indicated;
- (4) Escapeways and refuge alternatives designated by means of symbols.

30 CFR § 75.1203
Availability of mine map.

[STATUTORY PROVISIONS]

The coal mine map and any revision and supplement thereof shall be available for inspection by the Secretary or his authorized representative, by coal mine inspectors of the State in which the mine is located, by miners in the mine and their representatives and by operators of adjacent coal mines and by persons owning, leasing, or residing on surface areas of such mines or areas adjacent to such mines. The operator shall furnish to the Secretary or his authorized representative and to the Secretary of Housing and Urban Development, upon request, one or more copies of such maps and any revision and supplement thereof. Such map or revision and supplement thereof shall be kept confidential and its contents shall not be divulged to any other person, except to the extent necessary to carry out the provisions of this Act and in connection with the functions and responsibilities of the Secretary of Housing and Urban Development.

30 CFR § 75.1403-5
Criteria--Belt conveyors.

- (a) Positive-acting stop controls should be installed along all belt conveyors used to transport men, and such controls should be readily accessible and maintained so that the belt can be stopped or started at any location.
- (b) Belt conveyors used for regularly scheduled mantrips should be stopped while men are loading or unloading.
- (c) All belt conveyors used for the transportation of persons should have a minimum vertical clearance of 18 inches from the nearest overhead projection when measured from the edge of the belt and there should be at least 36 inches of side clearance where men board or leave such belt conveyors.
- (d) When men are being transported on regularly scheduled mantrips on belt conveyors the belt speed should not exceed 300 feet per minute when the vertical clearance is less than 24 inches, and should not exceed 350 feet per minute when the vertical clearance is 24 inches or more.
- (e) Adequate illumination including colored lights or reflective signs should be installed at all loading and unloading stations. Such colored lights and reflective signs should be so located as to be observable to all persons riding the belt conveyor.

(f) After supplies have been transported on belt conveyors such belts should be examined for unsafe conditions prior to the transportation of men on regularly scheduled mantrips, and belt conveyors should be clear before men are transported.

(g) A clear travelway at least 24 inches wide should be provided on both sides of all belt conveyors installed after March 30, 1970. Where roof supports are installed within 24 inches of a belt conveyor, a clear travelway at least 24 inches wide should be provided on the side of such support farthest from the conveyor.

(h) On belt conveyors that do not transport men, stop and start controls should be installed at intervals not to exceed 1,000 feet. Such controls should be properly installed and positioned so as to be readily accessible.

(i) Telephone or other suitable communications should be provided at points where men or supplies are regularly loaded on or unloaded from the belt conveyors.

(j) Persons should not cross moving belt conveyors, except where suitable crossing facilities are provided.

30 CFR § 75.1403-6

Criteria--Self-propelled personnel carriers.

(a) Each self-propelled personnel carrier should:

(1) Be provided with an audible warning device;

(2) Be provided with a sealed-beam headlight, or its equivalent, on each end;

(3) Be provided with reflectors on both ends and sides.

(b) In addition, each track-mounted self-propelled personnel carrier should:

(1) Be provided with a suitable lifting jack and bar, which shall be secured or carried in a tool compartment;

(2) Be equipped with 2 separate and independent braking systems properly installed and well maintained;

(3) Be equipped with properly installed and well-maintained sanding devices, except that personnel carriers (jitneys), which transport not more than 5 men, need not be equipped with such sanding device;

(4) If an open type, be equipped with guards of sufficient strength and height to prevent personnel from being thrown from such carriers.

30 CFR § 75.1403-7

Criteria--Mantrips.

(a) Mantrips should be operated independently of any loaded trip, empty trip, or supply

trip and should not be operated within 300 feet of any trip, including another mantrip.

(b) A sufficient number of mantrip cars should be provided to prevent overcrowding of men.

(c) Mantrips should not be pushed.

(d) Where mantrips are operated by locomotives on slopes such mantrips should be coupled to the front and rear by locomotives capable of holding such mantrips. Where ropes are used on slopes for mantrip haulage, such conveyances should be connected by chains, steel ropes, or other effective devices between mantrip cars and the rope.

(e) Safety goggles or eyeshields should be provided for all persons being transported in open-type mantrips.

(f) All trips, including trailers and sleds, should be operated at speeds consistent with conditions and the equipment used, and should be so controlled that they can be stopped within the limits of visibility.

(g) All mantrips should be under the direction of a supervisor and the operator of each mantrip should be familiar with the haulage safety rules and regulations.

(h) Men should proceed in an orderly manner to and from mantrips and no person should be permitted to get on or off a moving mantrip.

(i) [Reserved]

(j) Mantrips should not be permitted to proceed until the operator of the mantrip is assured that he has a clear road.

(k) Supplies or tools, except small hand tools or instruments, should not be transported with men.

(l) At places where men enter or leave mantrip conveyances, ample clearance should be provided and provisions made to prevent persons from coming in contact with energized electric circuits.

(m) The mine car next to a trolley locomotive should not be used to transport men. Such cars may be used to transport small tools and supplies. This is not to be construed as permitting the transportation of large or bulky supplies such as shuttle car wheel units, or similar material.

(n) Drop-bottom cars used to transport men should have the bottoms secured with an additional locking device.

(o) Extraneous materials or supplies should not be transported on top of equipment; however, materials and supplies that are necessary for or related to the operation of such equipment may be transported on top of such equipment if a hazard is not introduced.

30 CFR § 75.1403-10
Criteria--Haulage; general.

- (a) A permissible trip light or other approved device such as reflectors, approved by the Coal Mine Safety District Manager(s), should be used on the rear of trips pulled, on the front of trips pushed and on trips lowered in slopes. However, trip lights or other approved devices need not be used on cars being shifted to and from loading machines, on cars being handled at loading heads, during gathering operations at working faces, when trailing locomotives are used, or on trips pulled by animals.
- (b) Cars on main haulage roads should not be pushed, except where necessary to push cars from side tracks located near the working section to the producing entries and rooms, where necessary to clear switches and sidetracks, and on the approach to cages, slopes, and surface inclines.
- (c) Warning lights or reflective signs or tapes should be installed along haulage roads at locations of abrupt or sudden changes in the overhead clearance.
- (d) No person, other than the motorman and brakeman, should ride on a locomotive unless authorized by the mine foreman, and then only when safe riding facilities are provided. No person should ride on any loaded car or on the bumper of any car. However, the brakeman may ride on the rear bumper of the last car of a slow moving trip pulled by a locomotive.
- (e) Positive-acting stopblocks or derails should be used where necessary to protect persons from danger of runaway haulage equipment.
- (f) An audible warning should be given by the operator of all self-propelled equipment including off-track equipment, where persons may be endangered by the movement of the equipment.
- (g) Locomotives and personnel carriers should not approach to within 300 feet of preceding haulage equipment, except trailing locomotives that are an integral part of the trip.
- (h) A total of at least 36 inches of unobstructed side clearance (both sides combined) should be provided for all rubber-tired haulage equipment where such equipment is used.
- (i) Off-track haulage roadways should be maintained as free as practicable from bottom irregularities, debris, and wet or muddy conditions that affect the control of the equipment.
- (j) Operators of self-propelled equipment should face in the direction of travel.
- (k) Mechanical steering and control devices should be maintained so as to provide positive control at all times.
- (l) All self-propelled rubber-tired haulage equipment should be equipped with well maintained brakes, lights, and a warning device.

(m) On and after March 30, 1971, all tram control switches on rubber-tired equipment should be designed to provide automatic return to the stop or off position when released.

30 CFR § 75.1504

Mine emergency evacuation training and drills.

Each operator of an underground coal mine shall conduct mine emergency evacuation training and drills and require all miners to participate.

(a) *Schedule of training and drills.* Each miner shall participate in a mine emergency evacuation training and drill once each quarter. Quarters shall be based on a calendar year (Jan-Mar, Apr-Jun, Jul-Sep, Oct-Dec). In addition--

(1) A newly hired miner, who has not participated in a mine emergency evacuation training and drill at the mine within the previous 3 months, shall participate in the next applicable mine emergency evacuation training and drill.

(2) Prior to assuming duties on a section or outby work location, a foreman shall travel both escapeways in their entirety.

(b) *Content of quarterly training and drill.* Each quarterly evacuation training and drill shall include the following:

(1) Hands-on training on all types of self-rescue devices used at the mine, which includes--

(i) Instruction and demonstration in the use, care, and maintenance of self-rescue devices;

(ii) The complete donning of the SCSR by assuming a donning position, opening the device, activating the device, inserting the mouthpiece, and putting on the nose clip; and

(iii) Transferring between all applicable self-rescue devices.

(2) Training that emphasizes the importance of--

(i) Recognizing when the SCSR is not functioning properly and demonstrating how to initiate and reinstate the starting sequence;

(ii) Not removing the mouthpiece, even to communicate, until the miner reaches fresh air; and

(iii) Proper use of the SCSR by controlling breathing and physical exertion.

(3) A realistic escapeway drill that is initiated and conducted with a different approved scenario each quarter and during which each miner--

(i) Travels the primary or alternate escapeway in its entirety, alternating escapeways each quarter;

(ii) Physically locates and practices using the continuous directional lifelines or equivalent devices and tethers, and physically locates the stored SCSRs and refuge alternatives;

(iii) Traverses undercasts or overcasts and doors;

(iv) Switches escapeways, as applicable; and

(v) Negotiates any other unique escapeway conditions.

(4) A review of the mine and escapeway maps, the firefighting plan, and the mine emergency evacuation plan in effect at the mine, which shall include:

(i) Informing miners of the locations of fire doors, check curtains, changes in the routes of travel, and plans for diverting smoke from escapeways.

(ii) Locating escapeways, exits, routes of travel to the surface, abandoned areas, and refuge alternatives.

(5) Operation of the fire suppression equipment available in the mine and the location and use of firefighting equipment and materials.

(6) Reviewing the procedures for deploying refuge alternatives and components.

(7) For miners who will be constructing the 15 psi stoppings prior to an event, reviewing the procedures for constructing them.

(8) Reviewing the procedures for use of the refuge alternatives and components.

(9) Task training in proper transportation of the refuge alternatives and components.

(c) *Annual expectations training.* Over the course of each year, each miner shall participate in expectations training that includes the following:

(1) Donning and transferring SCSRs in smoke, simulated smoke, or an equivalent environment.

(2) Breathing through a realistic SCSR training unit that provides the sensation of SCSR airflow resistance and heat.

(3) Deployment and use of refuge alternatives similar to those in use at the mine, including--

(i) Deployment and operation of component systems; and

(ii) Instruction on when to use refuge alternatives during a mine emergency, emphasizing that it is the last resort when escape is impossible.

(4) A miner shall participate in expectations training within one quarter of being employed at the mine.

(d) *Certification of training and drills.* At the completion of each training or drill required in this section, the operator shall certify by signature and date that the training or drill was held in accordance with the requirements of this section.

(1) This certification shall include the names of the miners participating in the training or drill. For each miner, this certification shall list the content of the training or drill component completed, including the escapeway traveled and scenario used, as required in paragraphs (b) and (c) of this section.

(2) Certifications shall be kept at the mine for one year.

(3) Upon request, the certifications shall be made available to an authorized representative of the Secretary and the representative of the miners.

(4) Upon request, a copy of the certification that shows his or her own training shall be provided to the participating miner.

30 CFR § 75.1506
Refuge alternatives.

(a) Each operator shall provide refuge alternatives and components as follows:

(1) Prefabricated self-contained units, including the structural, breathable air, air monitoring, and harmful gas removal components of the unit, shall be approved under 30 CFR part 7; and

(2) The structural components of units consisting of 15 psi stoppings constructed prior to an event shall be approved by the District Manager, and the breathable air, air monitoring, and harmful gas removal components of these units shall be approved under 30 CFR part 7.

(3) Prefabricated refuge alternative structures that states have approved and those that MSHA has accepted in approved Emergency Response Plans (ERPs) that are in service prior to March 2, 2009 are permitted until December 31, 2018, or until replaced, whichever comes first. Breathable air, air-monitoring, and harmful gas removal components of either a prefabricated self-contained unit or a unit consisting of 15 psi stoppings constructed prior to an event in a secure space and an isolated atmosphere that states have approved and those that MSHA has accepted in approved ERPs that are in use prior to March 2, 2009 are permitted until December 31, 2013, or until replaced, whichever comes first. Refuge alternatives consisting of materials pre-positioned for miners to deploy in a secure space with an isolated atmosphere that MSHA has accepted

in approved ERPs that are in use prior to March 2, 2009 are permitted until December 31, 2010, or until replaced, whichever comes first.

(b) Except as permitted under paragraph (a)(3) of this section, each operator shall provide refuge alternatives with sufficient capacity to accommodate all persons working underground.

(1) Refuge alternatives shall provide at least 15 square feet of floor space per person and 30 to 60 cubic feet of volume per person according to the following chart. The airlock can be included in the space and volume if waste is disposed outside the refuge alternative.

----- Mining height (inches) -----	Unrestricted volume (cubic feet) per person* -----
36 or less.....	30
>36-<=42.....	37.5
>42-<=48.....	45
>48-<=54.....	52.5
>54.....	60
-----	-----

* Includes an adjustment of 12 inches for clearances.

(2) Refuge alternatives for working sections shall accommodate the maximum number of persons that can be expected on or near the section at any time.

(3) Each refuge alternative for outby areas shall accommodate persons reasonably expected to use it.

(c) Refuge alternatives shall be provided at the following locations:

(1) Within 1,000 feet from the nearest working face and from locations where mechanized mining equipment is being installed or removed except that for underground anthracite coal mines that have no electrical face equipment, refuge alternatives shall be provided if the nearest working face is greater than 2,000 feet from the surface.

(2) Spaced within one-hour travel distances in outby areas where persons work such that persons in outby areas are never more than a 30- minute travel distance from a refuge alternative or safe exit. However, the operator may request and the District Manager may approve a different location in the ERP. The operator's request shall be based on an assessment of the risk to persons in outby areas, considering the following factors: proximity to seals; proximity to potential fire or ignition sources; conditions in the outby areas; location of stored SCSRs; and proximity to the most direct, safe, and practical route to an intake escapeway.

(d) Roof and rib support for refuge alternative locations shall be specified in the mine's roof control plan.

(e) The operator shall protect the refuge alternative and contents from damage during transportation, installation, and storage.

(f) A refuge alternative shall be removed from service if examination reveals damage that interferes with the functioning of the refuge alternative or any component.

(1) If a refuge alternative is removed from service, the operator shall withdraw all persons from the area serviced by the refuge alternative, except those persons referred to in Sec. 104(c) of the Mine Act.

(2) Refuge alternative components removed from service shall be replaced or be repaired for return to service in accordance with the manufacturer's specifications.

(g) At all times, the site and area around the refuge alternative shall be kept clear of machinery, materials, and obstructions that could interfere with the deployment or use of the refuge alternative.

(h) Each refuge alternative shall be conspicuously identified with a sign or marker as follows:

(1) A sign or marker made of a reflective material with the word "REFUGE" shall be posted conspicuously at each refuge alternative.

(2) Directional signs made of a reflective material shall be posted leading to each refuge alternative location.

(i) During use of the refuge alternative, the atmosphere within the refuge alternative shall be monitored. Changes or adjustments shall be made to reduce the concentration of methane to less than 1 percent; to reduce the concentration of carbon dioxide to 1 percent or less and excursions not exceeding 2.5 percent; and to reduce the concentration of carbon monoxide to 25 ppm or less. Oxygen shall be maintained at 18.5 to 23 percent.

(j) Refuge alternatives shall contain a fire extinguisher that--

(1) Meets the requirements for portable fire extinguishers used in underground coal mines under this part;

(2) Is appropriate for extinguishing fires involving the chemicals used for harmful gas removal; and

(3) Uses a low-toxicity extinguishing agent that does not produce a hazardous by-product when activated.

**30 CFR § 75.1600
Communications.**

[STATUTORY PROVISIONS]

Telephone service or equivalent two-way communication facilities, approved by the

Secretary or his authorized representative, shall be provided between the surface and each landing of main shafts and slopes and between the surface and each working section of any coal mine that is more than 100 feet from a portal.

30 CFR § 75.1600-1

Communication facilities; main portals; installation requirements.

A telephone or equivalent two-way communication facility shall be located on the surface within 500 feet of all main portals, and shall be installed either in a building or in a box-like structure designed to protect the facilities from damage by inclement weather. At least one of these communication facilities shall be at a location where a responsible person who is always on duty when men are underground can hear the facility and respond immediately in the event of an emergency.

30 CFR § 75.1600-3

Communications facilities; refuge alternatives.

(a) Refuge alternatives shall be provided with a communications system that consists of-

(1) A two-way communication facility that is a part of the mine communication system, which can be used from inside the refuge alternative; and

(2) An additional communication system and other requirements as defined in the communications portion of the operator's approved Emergency Response Plan.

30 CFR § 75.1700

Oil and gas wells.

[STATUTORY PROVISIONS]

Each operator of a coal mine shall take reasonable measures to locate oil and gas wells penetrating coalbeds or any underground area of a coal mine. When located, such operator shall establish and maintain barriers around such oil and gas wells in accordance with State laws and regulations, except that such barriers shall not be less than 300 feet in diameter, unless the Secretary or his authorized representative permits a lesser barrier consistent with the applicable State laws and regulations where such lesser barrier will be adequate to protect against hazards from such wells to the miners in such mine, or unless the Secretary or his authorized representative requires a greater barrier where the depth of the mine, other geologic conditions, or other factors warrant such a greater barrier.

30 CFR § 75.1702

Smoking; prohibition.

[STATUTORY PROVISIONS]

No person shall smoke, carry smoking materials, matches, or lighters underground, or smoke in or around oil houses, explosives magazines, or other surface areas where such practice may cause a fire or explosion. The operator shall institute a program, approved

by the Secretary, to insure that any person entering the underground area of the mine does not carry smoking materials, matches, or lighters.

30 CFR § 75.1710-1

Canopies or cabs; self-propelled *diesel-powered and* electric face equipment; installation requirements.

(a) Except as provided in paragraph (f) of this section, all self-propelled *diesel-powered and* electric face equipment, including shuttle cars, which is employed in the active workings of each underground coal mine on and after January 1, 1973, shall, in accordance with the schedule of time specified in paragraphs (a)(1), (2), (3), (4), (5), and (6) of this section, be equipped with substantially constructed canopies or cabs, located and installed in such a manner that when the operator is at the operating controls of such equipment he shall be protected from falls of roof, face, or rib, or from rib and face rolls. The requirements of this paragraph (a) shall be met as follows:

- (1) On and after January 1, 1974, in coal mines having mining heights of 72 inches or more;
- (2) On and after July 1, 1974, in coal mines having mining heights of 60 inches or more, but less than 72 inches;
- (3) On and after January 1, 1975, in coal mines having mining heights of 48 inches or more, but less than 60 inches;
- (4) On and after July 1, 1975, in coal mines having mining heights of 36 inches or more, but less than 48 inches;
- (5)(i) On and after January 1, 1976, in coal mines having mining heights of 30 inches or more, but less than 36 inches,
 - (a)(5)(ii) On and after July 1, 1977, in coal mines having mining heights of 24 inches or more, but less than 30 inches, and
- (6) On and after July 1, 1978, in coal mines having mining heights of less than 24 inches.

(b)(1) For purposes of this section, a canopy means a structure which provides overhead protection against falls of roof.

(2) For purposes of this section, a cab means a structure which provides overhead and lateral protection against falls of roof, rib, and face, or rib and face rolls.

(c) In determining whether to install substantially constructed canopies as opposed to substantially constructed cabs, the operator shall consider and take into account the following factors:

- (1) The mining method used;
- (2) Physical limitations, including but not limited to the dip of the coalbed, and roof, rib, and face conditions;
- (3) Previous accident experience, if any, caused by falls of roof, rib, and face, or rib and face rolls;
- (4) Overhead protection, such as that afforded by a substantially constructed canopy, against falls of roof will always be required; and

(5) Lateral protection, such as that afforded by a substantially constructed cab, may also be necessary where the occurrence of falls of rib and face, or rib and face rolls is likely.

(d) For purposes of this section, a canopy or cab will be considered to be substantially constructed if a registered engineer certifies that such canopy or cab has the minimum structural capacity to support elastically: (1) A dead weight load of 18,000 pounds, or (2) 15 p.s.i. distributed uniformly over the plan view area of the structure, whichever is lesser.

(e) Evidence of the certification required by paragraph (d) of this section shall be furnished by attaching a plate, label, or other appropriate marking to the canopy or cab for which certification has been made, stating that such canopy or cab meets the minimum requirements for structural capacity set forth in paragraph (d) of this section. Written evidence of such certification shall also be retained by the operator, and shall be made available to an authorized representative of the Secretary upon request. Written evidence of certification may consist of the report of the registered engineer who certified the canopy or cab, or of information from the manufacturer of the canopy or cab stating that a registered engineer has certified that the canopy or cab meets the minimum requirements for structural capacity set forth in paragraph (d) of this section.

(f) An operator may apply to the Director of Technical Support, Mine Safety and Health Administration, Department of Labor, 1100 Wilson Boulevard Room 2329, Arlington, Virginia 22209-3939, for approval of the installation of devices to be used in lieu of substantially constructed canopies or cabs on self-propelled *diesel-powered and* electric face equipment. The Director of Technical Support may approve such devices if he determines that the use thereof will afford the equipment operator no less than the same measure of protection from falls of roof, face, or rib, or from rib and face rolls as would a substantially constructed canopy or cab meeting the requirements of this section.

**30 CFR § 75.1711-2
Sealing of slope or drift openings.**

Slope or drift openings required to be sealed under [§75.1711](#) shall be sealed with solid, substantial, incombustible material, such as concrete blocks, bricks or tile, or shall be completely filled with incombustible material for a distance of at least 25 feet into such openings.

**30 CFR § 75.1711-3
Openings of active mines.**

The openings of all mines not declared by the operator, to be inactive, permanently closed, or abandoned for less than 90 days shall be adequately fenced or posted with conspicuous signs prohibiting the entrance of unauthorized persons.

**30 CFR § 75.1714
Availability of approved self-rescue devices; instruction in use and location.**

(a) Each operator shall make available to each miner who goes underground, and to visitors authorized to enter the mine by the operator, an approved self-rescue device or

devices which is adequate to protect such person for 1 hour or longer.

(b) Before any person authorized by the operator goes underground, the operator shall instruct and train such person in accordance with provisions set forth in 30 CFR part 48.

**30 CFR § 75.1714-4
Additional Self-Contained Self-Rescuers (SCSRs).**

(a) Additional SCSRs in work places. In addition to the requirements in § § 75.1714, 75.1714-1, 75.1714-2, and 75.1714-3 of this part, the mine operator shall provide the following:

(1) At least one additional SCSR, which provides protection for a period of one hour or longer, for each person at a fixed underground work location.

(2) Additional SCSRs along the normal travel routes for pumpers, examiners, and other persons who do not have a fixed work location to be stored at a distance an average miner could walk in 30 minutes. The SCSR storage locations shall be determined by using one of the methods found under paragraph (c)(2) of this section.

(b) Additional SCSRs on mantrips. If a mantrip or mobile equipment is used to enter or exit the mine, at least one additional SCSR, which provides protection for a period of one hour or longer, shall be available for each person who uses such transportation from portal to portal.

(c) Additional SCSRs in escapeways. When each person underground cannot safely evacuate the mine within 30 minutes, the mine operator shall provide additional SCSRs stored in each required escapeway.

(1) Each storage location shall contain at least one SCSR, which provides protection for a period of one hour or longer, for every person who will be in by that location.

(2) Storage locations shall be spaced along each escapeway at 30- minute travel distances no greater than the distances determined by--

(i) Calculating the distance an average miner walks in 30 minutes by using the time necessary for each miner in a sample of typical miners to walk a typical length of each escapeway; or

(ii) Using the SCSR storage location spacing specified in the following table, except for escapeways with grades over 5 percent.

Average entry height	Maximum distance between SCSR storage locations (in ft.)
< 40 in. (Crawl).....	2,200
>40-<50 in. (Duck Walk).....	3,300
>50-<65 in. (Walk Head Bent).....	4,400
>65 in. (Walk Erect).....	5,700

(d) Additional SCSRs in hardened rooms. As an alternative to providing SCSR storage locations in each escapeway, the mine operator may store SCSRs in a hardened room located between adjacent escapeways.

(1) The hardened room shall be designed and constructed to the same explosion force criteria as seals.

(2) The hardened room shall include a means to provide independent, positive pressure ventilation from the surface during an emergency.

(3) The District Manager shall approve the design and construction of hardened rooms in the ventilation plan.

(4) These SCSR storage locations shall be spaced in accordance with paragraph (c) of this section.

(e) Storage location accessibility. All SCSRs required under this section shall be stored according to the manufacturers' instructions, in conspicuous locations readily accessible by each person in the mine.

(f) Storage location signs. A sign made of reflective material with the words "SCSRs" or "SELF-RESCUERS" shall be conspicuously posted at each storage location. Direction signs made of a reflective material shall be posted leading to each storage location.

30 CFR § 75.1715
Identification check system.

[STATUTORY PROVISIONS]

Each operator of a coal mine shall establish a check-in and check-out system which will provide positive identification of every person underground, and will provide an accurate record of the persons in the mine kept on the surface in a place chosen to minimize the danger of destruction by fire or other hazard. Such record shall bear a number identical to an identification check that is securely fastened to the lamp belt worn by the person underground. The identification check shall be made of a rust resistant metal of not less than 16 gauge.

30 CFR § 75.1716-1
Operations under water; notification by operator.

An operator planning to mine coal from coal mines opened after March 30, 1970, or from working sections in mines opened prior to such date, and in such manner that mining operations will be conducted, or tunnels constructed, under any river, stream, lake, or other body of water, shall give notice to the Coal Mine Safety District Manager in the district in which the mine is located prior to the commencement of such mining operations.

30 CFR § 75.1716-2
Permit required.

If in the judgment of the Coal Mine Safety District Manager the proposed mining operations referred to in [§75.1716-1](#) constitute a hazard to miners, he shall promptly so notify the operator that a permit is required.

30 CFR § 75.1718
Drinking water.

[STATUTORY PROVISIONS]

An adequate supply of potable water shall be provided for drinking purposes in the active workings of the mine, and such water shall be carried, stored, and otherwise protected in sanitary containers.

30 CFR § 75.1722
Mechanical equipment guards.

(a) Gears; sprockets; chains; drive, head, tail, and takeup pulleys; flywheels; couplings, shafts; sawblades; fan inlets; and similar exposed moving machine parts which may be contacted by persons, and which may cause injury to persons shall be guarded.

(b) Guards at conveyor-drive, conveyor-head, and conveyor-tail pulleys shall extend a distance sufficient to prevent a person from reaching behind the guard and becoming caught between the belt and the pulley.

(c) Except when testing the machinery, guards shall be securely in place while machinery is being operated.

30 CFR § 75.1725
Machinery and equipment; operation and maintenance.

(a) Mobile and stationary machinery and equipment shall be maintained in safe operating condition and machinery or equipment in unsafe condition shall be removed from service immediately.

(b) Machinery and equipment shall be operated only by persons authorized to operate such machinery or equipment.

(c) Repairs or maintenance shall not be performed on machinery until the power is off and the machinery is blocked against motion, except where machinery motion is necessary to make adjustments.

(d) Machinery shall not be lubricated manually while in motion, unless equipped with extended fittings or cups.

30 CFR § 75.1726

Performing work from a raised position; safeguards.

(a) Men shall not work on or from a piece of mobile equipment in a raised position until it has been blocked in place securely. This does not preclude the use of equipment specifically designed as elevated mobile work platforms.

(b) No work shall be performed under machinery or equipment that has been raised until such machinery or equipment has been securely blocked in position.

30 CFR § 75.1728

Power-driven pulleys.

(a) Belts, chains, and ropes shall not be guided onto power-driven moving pulleys, sprockets, or drums with the hands except on slow-moving equipment especially designed for hand feeding.

(b) Pulleys of conveyors shall not be cleaned manually while the conveyor is in motion.

(c) Coal spilled beneath belt conveyor drives or tail pieces shall not be removed while the conveyor is in motion, except where such coal can be removed without endangering persons.

30 CFR § 75.1730

Compressed air; general; compressed air systems.

(a) All pressure vessels shall be constructed, installed, and maintained in accordance with the standards and specifications of Section VIII "Unfired Pressure Vessels," of the American Society of Mechanical Engineers Boiler and Pressure Vessel Code (1971), which is hereby incorporated by reference and made a part hereof. This document may be purchased from the American Society of Mechanical Engineers, 22 Law Drive, P.O. Box 2900, Fairfield, New Jersey 07007, Phone: 800-843-2763 (toll free); <http://www.asme.org>; and it is available for examination in every MSHA Coal Mine Safety and Health district office.

(b) Compressors and compressed-air receivers shall be equipped with automatic pressure-relief valves, pressure gages, and drain valves.

(c) Repairs involving the pressure system of compressors, receivers, or compressed-air-powered equipment shall not be attempted until the pressure has been relieved from that part of the system to be repaired.

(d) At no time shall compressed air be directed toward a person. When compressed air is used, all necessary precautions shall be taken to protect persons from injury.

(e) Safety chains, suitable locking devices, or automatic cut-off valves shall be used at connections to machines of high-pressure hose lines of three-fourths of an inch inside diameter or larger, and between high-pressure hose lines of three-fourths of an inch inside diameter or larger, where a connection failure would create a hazard. For

purposes of this paragraph, high-pressure means pressure of 100 p.s.i. or more.

30 CFR § 75.1902

Underground diesel fuel storage--general requirements.

(a) All diesel fuel must be stored in:

- (1) Diesel fuel tanks in permanent underground diesel fuel storage facilities;
- (2) Diesel fuel tanks on diesel fuel transportation units in permanent underground diesel fuel storage facilities or in temporary underground fuel storage areas; or
- (3) Safety cans.

(b) The total capacity of stationary diesel fuel tanks in permanent underground diesel fuel storage facilities must not exceed 1000 gallons.

(c)(1) Only one temporary underground diesel fuel storage area is permitted for each working section or in each area of the mine where equipment is being installed or removed.

(2) The temporary underground diesel fuel storage area must be located--

- (i) Within 500 feet of the loading point;
 - (ii) Within 500 feet of the projected loading point where equipment is being installed; or
 - (iii) Within 500 feet of the last loading point where equipment is being removed.
- (3) No more than one diesel fuel transportation unit at a time shall be parked in the temporary underground diesel fuel storage area.

(d) Permanent underground diesel fuel storage facilities and temporary underground diesel fuel storage areas must be--

- (1) At least 100 feet from shafts, slopes, shops, or explosives magazines;
- (2) At least 25 feet from trolley wires or power cables, or electric equipment not necessary for the operation of the storage facilities or areas; and
- (3) In a location that is protected from damage by other mobile equipment.

(e) Permanent underground diesel fuel storage facilities must not be located within the primary escapeway.

30 CFR § 75.1903

Underground diesel fuel storage facilities and areas; construction and safety precautions.

(a) Permanent underground diesel fuel storage facilities must be--

- (1) Constructed of noncombustible materials, including floors, roofs, roof supports, doors, and door frames. Exposed coal within fuel storage areas must be covered with noncombustible materials. If bulkheads are used they must be tightly sealed and must be built of or covered with noncombustible materials;
- (2) Provided with either self-closing doors or a means for automatic enclosure;
- (3) Provided with a means for personnel to enter and exit the facility after closure;
- (4) Ventilated with intake air that is coursed into a return air course or to the surface and that is not used to ventilate working places, using ventilation controls meeting the requirements of [§ 75.333\(e\)](#);

(5) Equipped with an automatic fire suppression system that meets the requirements of [§ 75.1912](#). Actuation of the automatic fire suppression system shall initiate the means for automatic enclosure;

(6) Provided with a means of containment capable of holding 150 percent of the maximum capacity of the fuel storage system; and

(7) Provided with a competent concrete floor or equivalent to prevent fuel spills from saturating the mine floor.

(b) Permanent underground diesel fuel storage facilities and temporary underground diesel fuel storage areas must be—

(1) Equipped with at least 240 pounds of rock dust and provided with two portable multipurpose dry chemical type (ABC) fire extinguishers that are listed or approved by a nationally recognized independent testing laboratory and have a 10A:60B:C or higher rating. Both fire extinguishers must be easily accessible to personnel, and at least one fire extinguisher must be located outside of the storage facility or area upwind of the facility, in intake air; or

(2) Provided with three portable multipurpose dry chemical type (ABC) fire extinguishers that are listed or approved by a nationally recognized independent testing laboratory and have a 10A:60B:C or higher rating. All fire extinguishers must be easily accessible to personnel, and at least one fire extinguisher must be located outside of the storage facility or area upwind of the facility, in intake air.

(3) Identified with conspicuous markings designating diesel fuel storage; and

(4) Maintained to prevent the accumulation of water.

(c) Welding or cutting other than that performed in accordance with paragraph (d) of this section shall not be performed within 50 feet of a permanent underground diesel fuel storage facility or a temporary underground diesel fuel storage area.

(d) When it is necessary to weld, cut, or solder pipelines, tanks, or other containers that may have contained diesel fuel, these practices shall be followed:

(1) Cutting or welding shall not be performed on or within pipelines, tanks, or other containers that have contained diesel fuel until they have been thoroughly purged and cleaned or inerted and a vent or opening is provided to allow for sufficient release of any buildup pressure before heat is applied.

(2) Diesel fuel shall not be allowed to enter pipelines, tanks, or containers that have been welded, soldered, brazed, or cut until the metal has cooled to ambient temperature.

30 CFR § 75.1906

Transport of diesel fuel.

- (a) Diesel fuel shall be transported only by diesel fuel transportation units or in safety cans.
- (b) No more than one safety can shall be transported on a vehicle at any time. The can must be protected from damage during transport. All other safety cans must be stored in permanent underground diesel fuel storage facilities.
- (c) Safety cans that leak must be promptly removed from the mine.
- (d) Diesel fuel transportation unit tanks and safety cans must be conspicuously marked as containing diesel fuel.
- (e) Diesel fuel transportation units must transport no more than 500 gallons of diesel fuel at a time.
- (f) Tanks on diesel fuel transportation units must be permanently fixed to the unit and have a total capacity of no greater than 500 gallons of diesel fuel.
- (g) Non-self-propelled diesel fuel transportation units with electrical components for dispensing fuel that are connected to a source of electrical power must be protected by a fire suppression device that meets the requirements of Secs. 75.1107-3 through 75.1107-6, and Secs. 75.1107-8 through 75.1107-16.
- (h) Diesel fuel transportation units and vehicles transporting safety cans containing diesel fuel must have at least two multipurpose, dry chemical type (ABC) fire extinguishers, listed or approved by a nationally recognized independent testing laboratory and having a 10A:60B:C or higher rating, with one fire extinguisher provided on each side of the vehicle.
- (i) Diesel fuel transportation units shall be parked only in permanent underground diesel fuel storage facilities or temporary underground diesel fuel storage areas when not in use.
- (j) When the distance between a diesel fuel transportation unit and an energized trolley wire at any location is less than 12 inches, the requirements of § 75.1003-2 must be followed.
- (k) Diesel fuel shall not be transported on or with mantrips or on conveyor belts.
- (l) Diesel fuel shall be stored and handled in accordance with the requirements of Secs. 75.1902 through 75.1906 of this part as of November 25, 1997.

30 CFR § 75.1914

Maintenance of diesel-powered equipment.

(a) Diesel-powered equipment shall be maintained in approved and safe condition or removed from service.

(b) Maintenance and repairs of approved features and those features required by [Secs. 75.1909](#) and [75.1910](#) on diesel-powered equipment shall be made only by a person qualified under [§ 75.1915](#).

(c) The water scrubber system on diesel-powered equipment shall be drained and flushed, by a person who is trained to perform this task, at least once on each shift in which the equipment is operated.

(d) The intake air filter on diesel-powered equipment shall be replaced or serviced, by a person who is trained to perform this task, when the intake air pressure drop device so indicates or when the engine manufacturer's maximum allowable air pressure drop level is exceeded.

(e) Mobile diesel-powered equipment that is to be used during a shift shall be visually examined by the equipment operator before being placed in operation. Equipment defects affecting safety shall be reported promptly to the mine operator.

(f) All diesel-powered equipment shall be examined and tested weekly by a person qualified under [§ 75.1915](#).

(1) Examinations and tests shall be conducted in accordance with approved checklists and manufacturers' maintenance manuals.

(2) Persons performing weekly examinations and tests of diesel-powered equipment under this paragraph shall make a record when the equipment is not in approved or safe condition. The record shall include the equipment that is not in approved or safe condition, the defect found, and the corrective action taken.

(g) Undiluted exhaust emissions of diesel engines in diesel-powered equipment approved under part 36 and heavy-duty nonpermissible diesel-powered equipment as defined in [§ 75.1908\(a\)](#) in use in underground coal mines shall be tested and evaluated weekly by a person who is trained to perform this task. The mine operator shall develop and implement written standard operating procedures for such testing and evaluation that specify the following:

(1) The method of achieving a repeatable loaded engine operating condition for each type of equipment;

(2) Sampling and analytical methods (including calibration of instrumentation) that are capable of accurately detecting carbon monoxide in the expected concentrations;

(3) The method of evaluation and interpretation of the results;

(4) The concentration or changes in concentration of carbon monoxide that will indicate a change in engine performance. Carbon monoxide concentration shall not exceed 2500 parts per million; and

(5) The maintenance of records necessary to track engine performance.

(h) Recordkeeping. Records required by paragraphs (f)(2) and (g)(5) shall be—

(1) Recorded in a secure book that is not susceptible to alteration, or recorded electronically in a computer system that is secure and not susceptible to alteration; and

(2) Retained at a surface location at the mine for at least 1 year and made available for inspection by an authorized representative of the Secretary and by miners' representatives.

(i) Diesel-powered equipment must be maintained in accordance with this part as of November 25, 1997.

Utah Code Title 40 - Chapter 2

Utah Administrative Code

Rule R-616-1 and R-616-4

UTAH CODE: Title 40 – Chapter 2 – Coal Mine Safety Act

40-2-101. Title.

This chapter is known as the "Coal Mine Safety Act."

40-2-102. Definitions.

As used in this chapter:

(1) "Adverse action" means to take any of the following actions against a person in a manner that affects the person's employment or contractual relationships:

- (a) discharge the person;
- (b) threaten the person;
- (c) coerce the person;
- (d) intimidate the person; or
- (e) discriminate against the person, including to discriminate in:
 - (i) compensation;
 - (ii) terms;
 - (iii) conditions;
 - (iv) location;
 - (v) rights;
 - (vi) immunities;
 - (vii) promotions; or
 - (viii) privileges.

(2) "Coal mine" means:

- (a) the following used in extracting coal from its natural deposits in the earth by any means or method:
 - (i) the land;
 - (ii) a structure;
 - (iii) a facility;
 - (iv) machinery;
 - (v) a tool;
 - (vi) equipment;

- (vii) a shaft;
- (viii) a slope;
- (ix) a tunnel;
- (x) an excavation; and
- (xi) other property; and

(b) the work of preparing extracted coal, including a coal preparation facility.

(3) "Commission" means the Labor Commission created in Section 34A-1-103.

(4) "Commissioner" means the commissioner appointed under Section 34A-1-201.

(5) "Council" means the Mine Safety Technical Advisory Council created in Section 40-2-203.

(6) "Director" means the director of the Utah Office of Coal Mine Safety appointed under Section 40-2-202.

(7) "Major coal mine accident" means any of the following at a coal mine located in Utah:

(a) a mine explosion;

(b) a mine fire;

(c) the flooding of a mine;

(d) a mine collapse; or

(e) the accidental death of an individual at a mine.

(8) "Mine Safety and Health Administration" means the federal Mine Safety and Health Administration within the United States Department of Labor.

(9) "Office" means the Utah Office of Coal Mine Safety created in Section 40-2-201.

(10) "Panel" means the Coal Miner Certification Panel created in Section 40-2-204.

(11) "Unsafe condition" means a danger that reasonably could be expected to cause serious harm to a person or property.

40-2-103. Scope and administration of chapter.

(1) This chapter applies to any coal mine located in the state.

(2) The commission:

(a) shall administer this chapter with the assistance of the office; and

(b) has jurisdiction over a coal mine in this state as set forth in this chapter.

40-2-104. Rulemaking authority.

In accordance with Title 63G, Chapter 3, Utah Administrative Rulemaking Act, the commission may make rules necessary to implement this chapter.

40-2-201. Utah Office of Coal Mine Safety created.

- (1) There is created within the commission the "Utah Office of Coal Mine Safety."
- (2) The office, under the direction of the commissioner, shall assist the commission in administering this chapter.

40-2-202. Appointment of director.

- 1) The director is the chief officer of the office and serves as the executive and administrative head of the office.
- (2)
 - (a) The commissioner shall appoint the director.
 - (b) The director may be removed from that position at the will of the commissioner.
- (3) The director shall receive compensation as provided by Title 67, Chapter 19, Utah State Personnel Management Act.
- (4) The director shall be experienced in administration and possess such additional qualifications as determined by the commissioner.

40-2-203. Mine Safety Technical Advisory Council created -- Duties.

- (1) Within the office there is created the "Mine Safety Technical Advisory Council" consisting of 13 voting members and 5 nonvoting members as provided in this section.
- (2)
 - (a) The commissioner shall appoint the voting members of the council as follows:
 - (i) one individual who represents a coal miner union;
 - (ii) two individuals with coal mining experience;
 - (iii) two individuals who represent coal mine operators;
 - (iv) one individual who represents an industry trade association;
 - (v) two individuals from local law enforcement agencies or emergency medical service providers;
 - (vi) three individuals who have expertise in one or more of the following:
 - (A) seismology;
 - (B) mining engineering;
 - (C) mine safety; or
 - (D) another related subject; and

(vii) two individuals from entities that provide mine safety training.

(b) The nonvoting members of the council are:

(i) the commissioner or the commissioner's designee;

(ii) the executive director of the Department of Natural Resources or the executive director's designee;

(iii) the commissioner of the Department of Public Safety or the commissioner's designee;

(iv) a representative of the Mine Safety and Health Administration selected by the Mine Safety and Health Administration; and

(v) a representative of the federal Bureau of Land Management selected by the federal Bureau of Land Management.

(3) (a) Except as required by Subsection (3)(b), a voting member shall serve a four-year term beginning July 1 and ending June 30.

(b) Notwithstanding the requirements of Subsection (3)(a), the commission shall, at the time of appointment of the initial voting members of the council, adjust the length of terms of the voting members to ensure that the terms of voting members are staggered so that approximately half of the voting members are appointed every two years.

(4) (a) The commissioner shall terminate the term of a voting member who ceases to be representative as designated by the voting member's original appointment.

(b) If a vacancy occurs in the voting members, the commissioner shall appoint a replacement for the unexpired term after soliciting recommendations from the council members.

(5) (a) The council shall meet at least quarterly.

(b) A majority of the voting members constitutes a quorum.

(c) A vote of the majority of the members of the council when a quorum is present constitutes an action of the council.

(6) (a) The commissioner or the commissioner's designee is the chair of the council.

(b) The commission shall staff the council.

(7) (a) (i) A member who is not a state or local government employee may not receive compensation or benefits for the member's service, but may receive per diem and expenses incurred in the performance of the member's official duties at the

rates established by the Division of Finance under Sections 63A-3-106 and 63A-3-107.

(ii) A member who is not a state or local government employee may decline to receive per diem and expenses for the member's service.

(b) (i) A state government officer and employee member who does not receive salary, per diem, or expenses from the agency the member represents for the member's service may receive per diem and expenses incurred in the performance of the member's official duties at the rates established by the Division of Finance under Sections 63A-3-106 and 63A-3-107.

(ii) A state government officer and employee member may decline to receive per diem and expenses for the member's service.

(c) (i) A local government member who does not receive salary, per diem, or expenses from the entity that the member represents for the member's service may receive per diem and expenses incurred in the performance of the member's official duties at the rates established by the Division of Finance under Sections 63A-3-106 and 63A-3-107.

(ii) A local government member may decline to receive per diem and expenses for the member's service.

(8) The council shall advise and make recommendations to the commission, the office, and the Legislature regarding:

(a) safety of coal mines located in Utah;

(b) prevention of coal mine accidents;

(c) effective coal mine emergency response;

(d) coal miner certification and recertification; and

(e) other topics reasonably related to safety of coal mines located in Utah.

40-2-204. Coal Miner Certification Panel created -- Duties.

(1) There is created within the office the "Coal Miner Certification Panel."

(2) The panel consists of:

(a) the commissioner or the commissioner's designee; and

(b) at least eight other members appointed by the commissioner with equal representation and participation from:

(i) management of coal mine operations;

(ii) hourly coal mining employees.

(3) A member appointed by the commissioner shall:

- (a) have at least five years' experience in coal mining in this state;
- (b) administer the certification test to an applicant referred to in Section 40-2-402;
- (c) consult with the commission about applicant qualifications specified in Section 40-2-402;
- (d) meet when directed by the commissioner or the commissioner's designee; and
- (e) hold office at the pleasure of the commissioner.

(4) A panel member who is not a government employee may not receive compensation or benefits for the member's services, but may receive per diem and expenses incurred in the performance of the member's official duties at the rates established by the Division of Finance under Sections 63A-3-106 and 63A-3-107.

40-2-301. Commission and office responsibilities.

(1) The commissioner shall:

- (a) direct the state's efforts to promote coal mine safety; and
- (b) participate with the Mine Safety and Health Administration in an investigation of a major coal mine accident in Utah.

(2) The commission shall establish by rule, made in accordance with Title 63G, Chapter 3, Utah Administrative Rulemaking Act:

- (a) a system consistent with Section 40-2-302 to receive, evaluate, and act on a report of an alleged unsafe condition at a coal mine; and
- (b) requirements for a coal mine operator regarding notification of a coal mine accident as part of a coal mine operator's emergency response plan.

(3) The office may:

- (a) conduct one or more studies to promote coal mine safety;
- (b) cooperate with educational and other organizations to promote mining engineering and mine safety training;
- (c) establish a cooperative relationship with the Mine Safety and Health Administration to promote coal mine safety in Utah;
- (d) serve as the lead state agency in developing and implementing state and local response and communication plans for major coal mine accidents in Utah; and

(e) implement the notification requirements established under Subsection (2)(b).

40-2-302. Reporting of an unsafe condition in coal mines -- Adverse action prohibited.

(1) Subject to the other provisions of this section, upon the office's receipt of information from a person of a possible unsafe condition in a coal mine located in Utah, the office may:

- (a) notify the federal Mine Safety and Health Administration;
- (b) notify another appropriate federal, state, or local government agency;
- (c) contact the operator of the coal mine;
- (d) refer the information to the council on a confidential basis; or
- (e) take any other authorized action.

(2) The commission, council, or office may not disclose or otherwise make public the identity of a person who reports a possible unsafe condition in a coal mine located in Utah unless that person authorizes the commission, council, or office to disclose the person's identity.

(3) A coal mine operator may not take adverse action against a person because that person:

- (a) reports an alleged unsafe mine condition; or
- (b) testifies, assists, or participates in any manner in an investigation, proceeding, or hearing under this chapter.

40-2-303. Annual report on coal mine safety.

(1) By October 1 of each year, the commission, office, and council shall compile and submit to the governor and the Legislature a comprehensive report of the status of coal mine safety within the state for the immediately preceding calendar year.

(2) The report required by this section shall include:

- (a) a compilation of major coal mine accidents or other coal mine emergencies within the state during the calendar year;
- (b) a statement of actions by the commission, office, or council to implement this chapter;
- (c) without a breach in confidentiality, a summary of reports of alleged unsafe conditions received by the office, with a statement of the office's responses;
- (d) recommendations for additional action to promote coal mine safety; and
- (e) any other items the commission, office, and council consider appropriate.

40-2-401. Necessity of certificate.

- (1) A person may not work in an occupation referred to in Section 40-2-402 unless granted a certificate by the commission.
- (2)
 - (a)
 - (i) The commission may grant a temporary coal mine foreman certificate or a temporary coal mine surface foreman certificate to an applicant who is:
 - (A) recommended by a coal mine; and
 - (B) interviewed and found competent by two panel members.
 - (ii) A certificate granted under Subsection (2)(a)(i) remains in effect until:
 - (A) the next scheduled certification test;
 - (B) the person is retested; or
 - (C) the commission terminates the certificate.
 - (b)
 - (i) The commission may grant a surface foreman certificate to a current holder of an underground mine foreman certificate, if the applicant has three years of varied surface mining experience.
 - (ii) A surface foreman certificate applicant may receive credit for surface experience in any other industry that has substantially equivalent surface facilities, if the applicant has performed or is presently performing the duties normally required of a surface foreman.
- (3)
 - (a) The commission shall collect a fee described in Subsection (3)(b) for each temporary certificate.
 - (b) The commission shall establish the fee by following Section 63J-1-303.
- (4)
 - (a) An owner, operator, contractor, lessee, or agent may not employ a worker in any occupation referred to in Section 40-2-402 who is uncertified.
 - (b) The certificate shall be on file and available for inspection to interested persons in the office of the coal mine.
- (5) The commission shall grant a certificate to an applicant referred to in Section 40-2-402 who:
 - (a) passes the certification test administered by the panel; and
 - (b) meets the qualifications specified in Section 40-2-402.
- (6)
 - (a) The commission may grant a certificate to an applicant involved in gilsonite or other hydrocarbon mining as provided by rule.
 - (b) The commission shall enact rules governing the certification procedure, test, and qualifications for applicants involved in gilsonite or other hydrocarbon mining.
- (7) The commission may by rule require certification and recertification of other coal mine occupations, including the certification of a new coal miner.

40-2-402. Certification requirements.

(1) The commission shall collect a fee for:

- (a) the taking of a certification test; or
- (b) the retaking of one or more sections of a certification test.

(2) (a) The commission shall establish fees by following Section 63J-1-303.

(b) Notwithstanding Subsection 63J-1-303(2)(e), the commission:

- (i) shall retain the fees as dedicated credits; and
- (ii) may only use the fees to administer the certification test.

(3) An applicant who fails any section of the certification test may retake that section of the test.

(4) (a) An applicant who wishes to obtain a mine foreman certificate shall have at least four years varied underground coal mining experience, of which:

- (i) two years' experience may be credited to a mining engineering graduate of an accredited four-year college; or
- (ii) one year's experience may be credited to a graduate of a two-year course in mining technology.

(b) An applicant who wishes to obtain a surface foreman certificate shall have at least three years of varied surface experience.

- (i) The commission may grant a surface foreman certificate applicant credit for surface experience in any other industry that has substantially equivalent surface facilities.

(c) An applicant who wishes to obtain a fire boss certificate shall have at least two years of underground coal mining experience, of which:

- (i) one year's experience may be credited to a mining engineering graduate of an accredited four-year college; or
- (ii) six months' experience may be credited to a graduate of a two-year course in mining technology.

(d) An applicant who wishes to obtain an underground mine electrician certificate shall have at least one year of varied electrical experience as specified in 30 C.F.R. Sec. 75.153.

(e) An applicant who wishes to obtain a surface mine electrician certificate shall have at least one year of varied surface electrical experience as specified in 30 C.F.R. Sec. 77.103.

(5) A certificate granted under Section 40-2-401 and this section shall expire if the certificate holder ceases to work in the mining industry or a mine related industry for more than five consecutive years.

R616. Labor Commission, Boiler and Elevator Safety.

R616-1. Coal, Gilsonite, or other Hydrocarbon Mining Certification.

R616-1-1. Authority and Purpose.

This rule is established pursuant to Section 40-2-1.1 and Section 40-2-14, which authorize the Labor Commission to enact rules governing the certification of individuals to work in the positions of underground mine foreman, surface mine foreman, fire boss, underground electrician or surface electrician in coal mines, gilsonite mines or other hydrocarbon mines in Utah.

R616-1-2. Definitions.

A. "Commission" means the Labor Commission created in Section 34A-1-103.

B. "Division" means the Division of Boiler and Elevator Safety of the Labor Commission.

C. "Certification" means a person being judged competent and qualified by the Division for a mining position identified in Section 40-2-15 by meeting standards established by the Division and the examining panel pursuant to the requirements in Sections 40-2-14 through 16.

R616-1-3. Fees.

As required by Section 40-2-15, the Labor Commission shall establish and collect fees for certification sufficient to fund the Commission's miner certification process. The Commission's fees schedule shall be submitted to the Legislature for approval pursuant to Section 63-38-3(2).

R616-1-4. Code of Federal Regulations.

The provisions of 30 CFR, sections 1 through 199, "Federal Underground Coal Mine Safety Standards," 11th ed., July 1, 1996, are hereby incorporated by reference.

R616-1-5. Initial Agency Action.

Division action either granting or denying an applicant's application for certification are classified as informal adjudicative actions pursuant to Section 63-46b-4 of the Utah Administrative Procedures Act and shall be adjudicated accordingly.

Authorizing, and Implemented or Interpreted Law: 34A-1-104; 40-2-1 et seq.

R616-4. Coal Mine Safety.

R616-4-1. Authority and Purpose.

This rule is established pursuant to authority granted the Commission by 40-2-104 and 40-2-301(2) for the purpose of improving coal mine safety, preventing coal mine accidents, and improving coal mine accident response consistent with the Coal Mine Safety Act.

R616-4-3. Examining Coal Mines.

(1) Pursuant to 34A-1-406 and other provisions of Utah Law, representatives of the Utah Labor Commission are authorized to enter places of employment, including coal mines, for purposes of "examining the provisions made for the health and safety of the employees in the place of employment."

(2) If the Director of the Office of Coal Mine Safety determines that the safety of an employee is or will be endangered by activities or conditions in a coal mine, the Director may:

(a) notify the employee and mine management of the danger and specify actions necessary to remedy the danger;

(b) notify the Mine Safety and Health Administration of the danger;

(c) notify other appropriate federal, state, and local government agencies; and

(d) take such other action as authorized by law to eliminate or mitigate the danger.

R616-4-4. Accident Notification Requirements.

(1) After the occurrence of any coal mine accident that is required by MSHA or regulations 30 CFR Part 50 to be immediately reported to MSHA, a coal mine operator shall first notify MSHA of the accident. Immediately after completing its report to MSHA, the coal mine operator shall then report the accident to the Office of Coal Mine Safety at telephone number 1-888-988-6463.

R616-4-5. Emergency Response Training.

(1) Beginning with the 2010 calendar year, each coal mine operator shall annually hold an in person meeting with law enforcement, public safety and health care providers for the purpose of reviewing and refining coal mine emergency response plans. The Office of Coal Mine Safety shall be notified of and arrange to participate in each such meeting, but the inability of the Office or any local, state, and federal emergency response personnel to attend such a meeting shall not prevent the operator from proceeding with the meeting as scheduled.

MINE LAW

Questions for Review

Q: What are the qualifications for fire bosses employed in Utah coal mines?

A: CFR 75.100 and Utah Code 40-2-402 (4)(c)

Q: According to the Miners Act, Who, in case of necessity, is permitted to pass beyond a danger signal at the entrance of a mine?

A: ACT 104 C 1, 2, 3, 4

Q: What is the duty of a fire boss when he finds, what he considers, a danger to persons entering an area or place?

A: CFR 75.211

Q: What shall be done at or near working faces before and during, welding or cutting in all mines?

A: CFR 75.1106

Q: In what quantity shall rock dust be maintained on the roof, ribs and bottom of the intake, beltline, or working section?

A: CFR 75.403

Q: On a daily basis, spot-check torques on at least 10 percent of the tensioned roof bolts must be made. Where shall the checks be made?

A: CFR 75.204

Q: When the equipment is operated, the water scrubber system on diesel powered equipment shall be drained and flushed how often?

A: CFR 75.1914

Q: What are the requirements for the transportation of compressed gas cylinders?

A: CFR 75.1106-2

Q: When is it permissible to lubricate moving machinery, such as conveyor belt idlers?
A: CFR 75.1725

Q: How often shall mine maps be updated and what must they include?
A: CFR 75.1202-1

Q: The mine map of which roof falls are plotted shall be available at the mine site for inspection by whom?
A: CFR 75.1203

Q: In reference to compressed air, what is the definition of “high pressure”?
A: CFR 75.1730

Q: The accident and injury experience at each mine shall be recorded. How often must it be reviewed?
A: CFR 75.223

Q: In pillar recover, before mining a final stump, what must be in place?
A: CFR 75.207

Q: Self-propelled personnel carriers must have what?
A: CFR 75.1403-6

Q: In what quantity shall rock dust be maintained in return air courses?
A: CFR 75.403

Q: Tensioned roof bolts (mechanical) that provide support by creating a beam of laminated strata shall be at least how long?
A: CFR 75.204

Q: Where shall drinking water be provided, and how shall it be handled and stored?

A: CFR 75.1718

Q: Conventional roof support materials shall meet certain specifications. What is the minimum diameter of cross-sectional area of wooden posts that are over 108 to 132 inches in length?

A: CFR 75.206

Q: When conventional roof support materials are used as the only means of support, they shall be installed how far from the uncut face?

A: CFR 75.206

Q: Full and partial pillar recovery shall not be conducted on the same pillar line, except when?

A: CFR 75.207

Q: When manually installing temporary supports, the first temporary support shall be set no more than _____ from a permanent roof support and the rib?

A: CFR 75.210

Q: Where roof bolting is the sole means of roof support, openings (entries) should not exceed what width?

A: CFR 75.222

CHAPTER SIX

INSTRUMENTS AND DEFINITIONS

1. Instruments
2. Definitions of coal mining terms
3. Questions and Review

INSTRUMENTS

BAROMETER

A barometer is an instrument used to measure the pressure of the atmosphere. The use of the barometer is a practical advantage, in the operation of a mine, by showing the change in the atmospheric pressure as they occur. A careful study of these changes in pressure in connection with the gaseous condition of the mine workings, enables a more intelligent arrangement and control of the ventilation, and will often forecast a dangerous gaseous condition existing in the mine, owing to a rapid fall of the barometer.

Regular barometer reading, in connection with mining operations, are important in respect to their indicating the expansive effect produced on a sudden fall of the barometer or decrease of atmospheric pressure. As a result of this, the air and gases confined in a large abandoned area are forced out into the live workings, causing the explosive condition of the mine air to be considerably increased for a time.

MINE WATER GAUGE

A water gauge consists of a glass u tube partially filled with water open at both ends and is graduated in inches and tenths thereof.

A water gauge is used in Mine Ventilation, for the purpose of computing the power on the air. It should, therefore, be placed on the fan drift, in order that it shall take into account the entire resistance of the shaft and mine, which the ventilating fan must overcome. In this position of the water gauge its reading indicates the pressure established by the fan, which is above or below the atmospheric pressure, according as the fan is blowing air into or exhausting air from the mine. The rise or fall of one inch difference in the level of the water column denotes 5.2 lbs. per square feet.

Example: If the water gauge suddenly shows a rise of half an inch, without having increased the speed of the fan, what would you understand from this and what would be your movements?

Assuming the fan is running at the same speed and the water gauge is observed to take a sudden rise of half an inch, it is natural to suppose that the increased gauge is due to a greater mine resistance, which is probably caused by some undue obstruction of the air current. This will call for an immediate investigation to ascertain the cause. It may be that a heavy fall of roof has blocked the airway at some point in the mine; or the obstruction may be caused by the movement of a particularly heavily loaded trip against the air.

The sum of the difference of the two water levels as shown on the scale is the water gauge reading.

THERMOMETER

An instrument for determining temperature, and used to measure temperatures of sealed area and to determine the relative humidity of mine air.

Regular readings of the thermometer taken inside and outside of the mine are important as showing a greater or less capacity of the air for carrying moisture or absorbing moisture from the mine. Hygrometer reading are of greatest value in a dry and dusty mine.

ANEMOMETER

The form of Anemometer generally used in coal mining consists of a metal ring within which is set a rotating propeller of blade. The air current striking the inclined blades rotates the bane, the number of revolutions being recorded on the face of the dial by means of a series of gears. The instrument is employed to measure the velocity of the air current in mine airways as expressed in feet.

In taking a reading a place is first found where the air ahs a straight course and will not be deflected unequally to either side, and where the area of the airway can be measured.

Hold the anemometer at arm's length in such a way that the blades will turn in a plane at right angles to the air current, using reset lever on anemometer, so all dial hands will be on zero, the brake lever near handle is released and anemometer exposed to the air current for one full minute, moving about so as to obtain an average reading for the enter sectional area of the airway after which the brake is applied. The reading of the anemometer times the area of the airway in square feet gives the quantity of air passing in cubic feet per minute.

Example Problem: How would you determine the quantity of air passing where the section of the airway is ten feet wide, five feet high, and the air velocity of the anemometer reads 300?

Answer: Calculate the sectional area of the airway, thus: $10 \times 5 = 50$ sq. ft. the quantity of air passing is $300 \times 50 = 15,000$ cu. ft. per minute.

Air reading - 310 (Velocity)

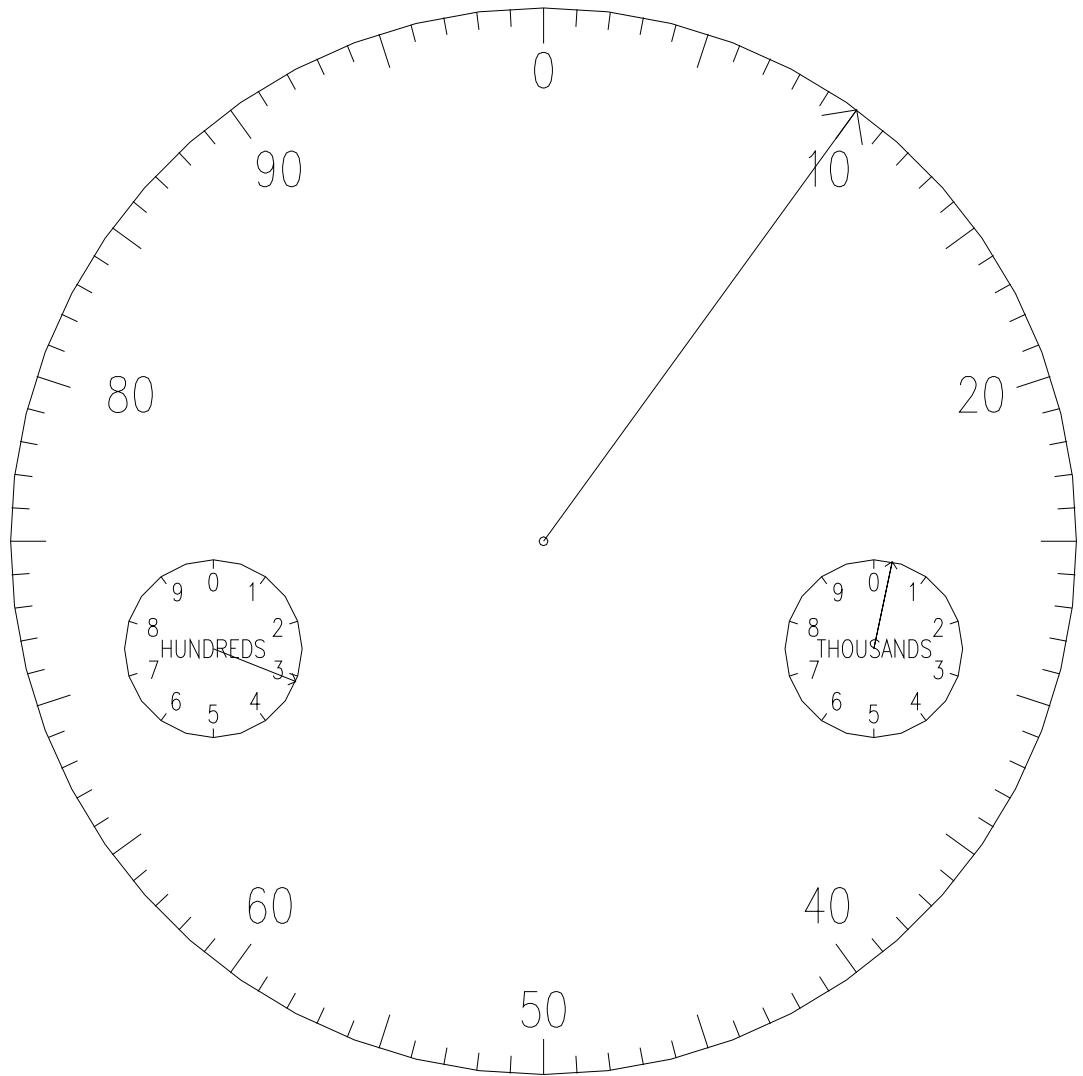

675 (Velocity)

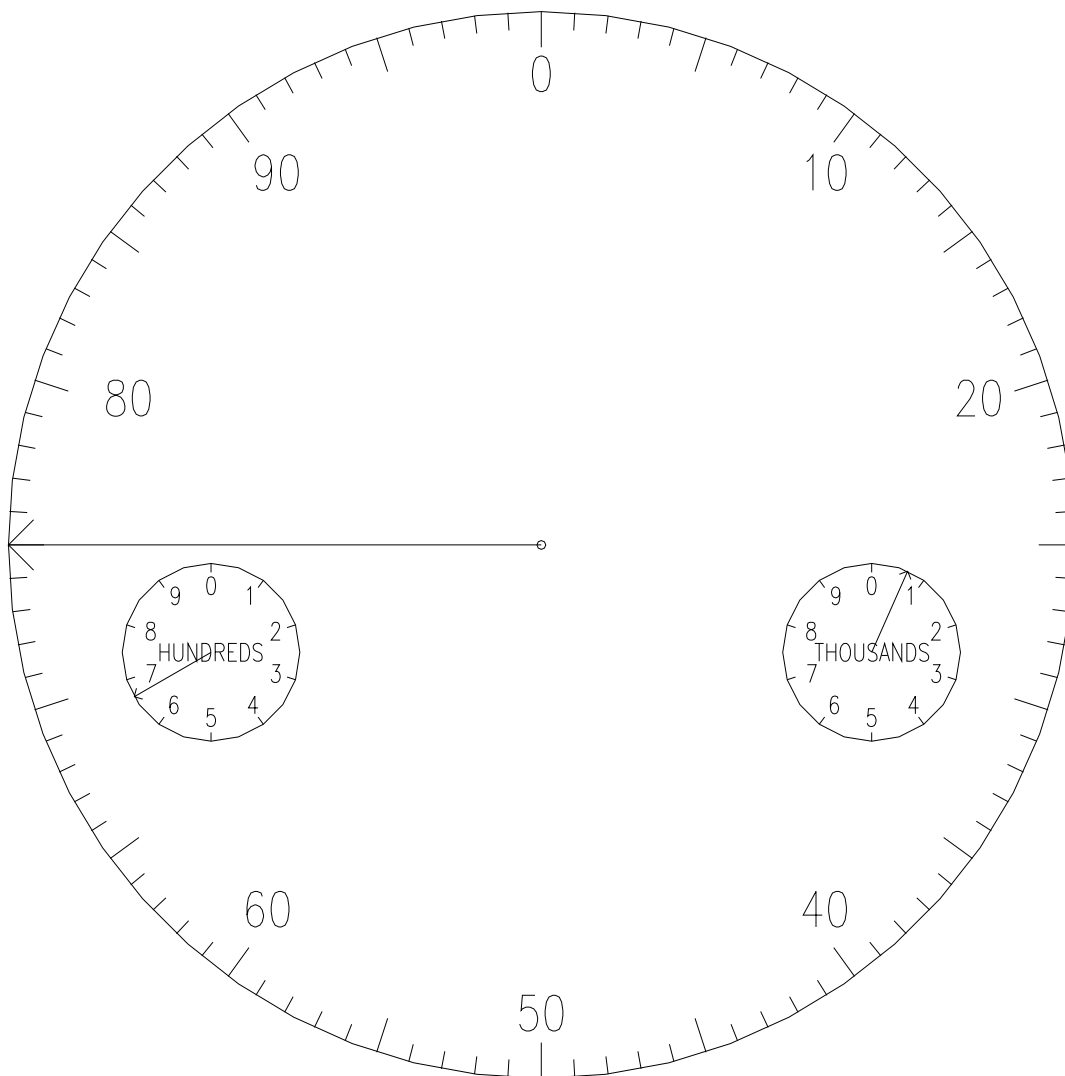

997- (Velocity)

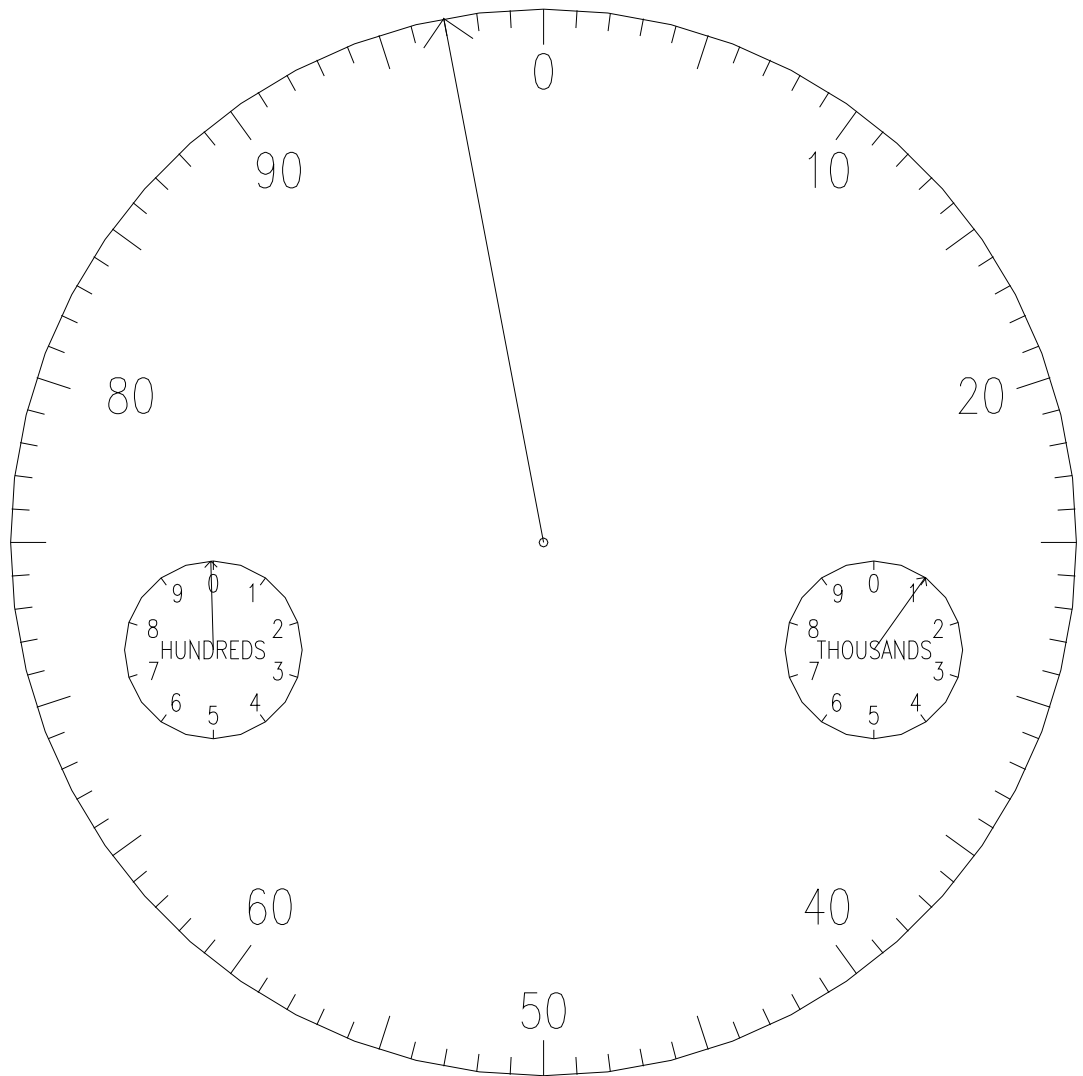

4,561 (Velocity)

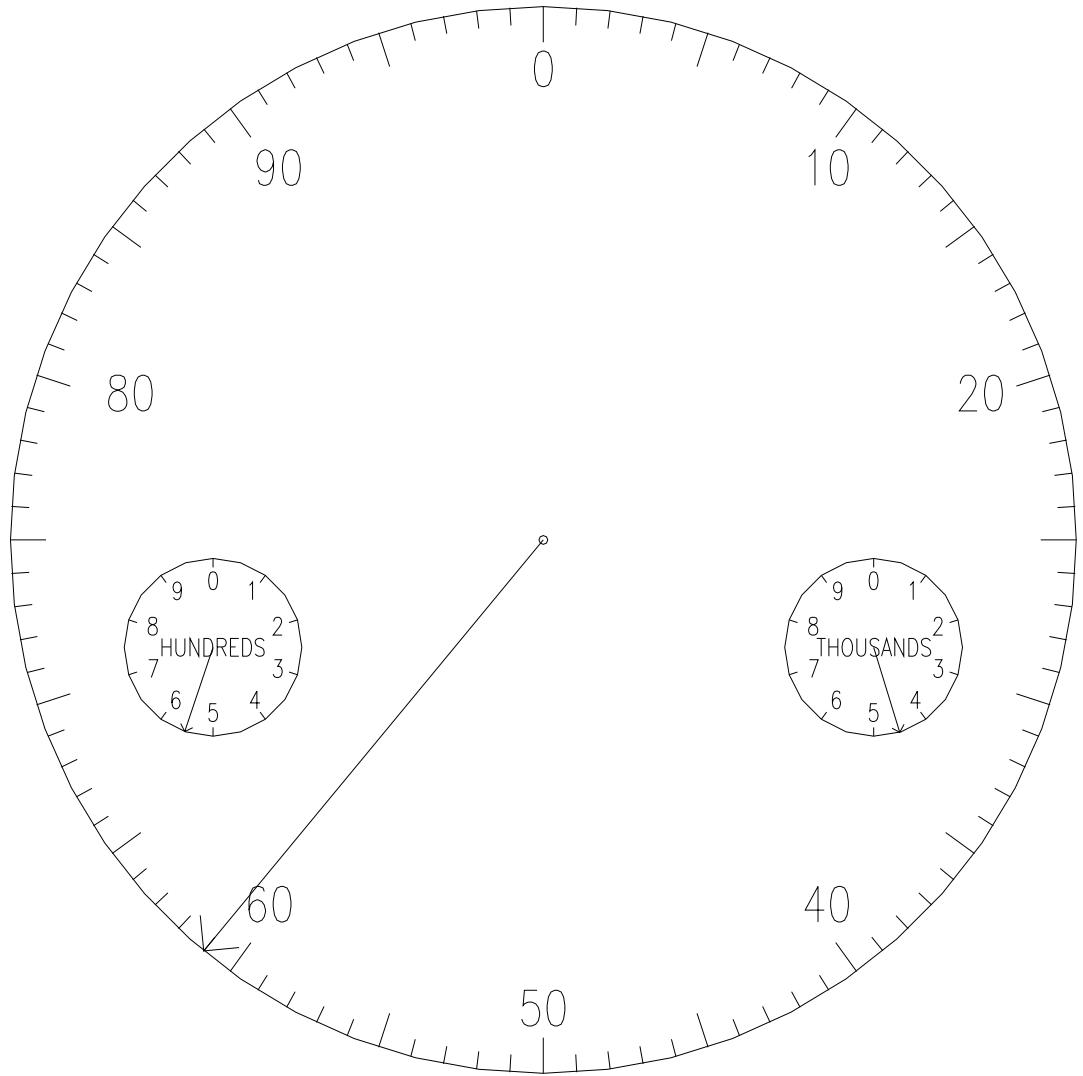

5,001 (Velocity)

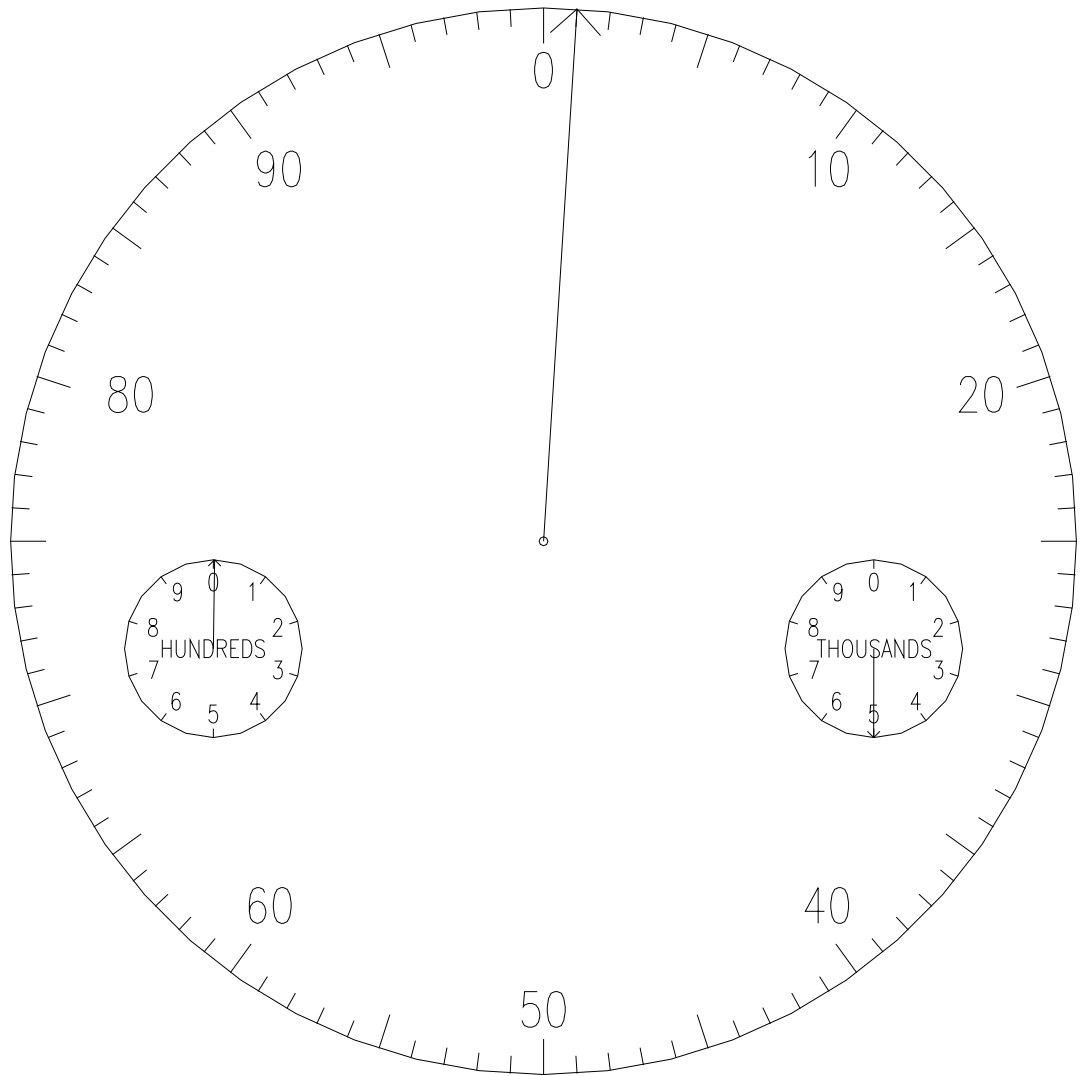

509 (Velocity)

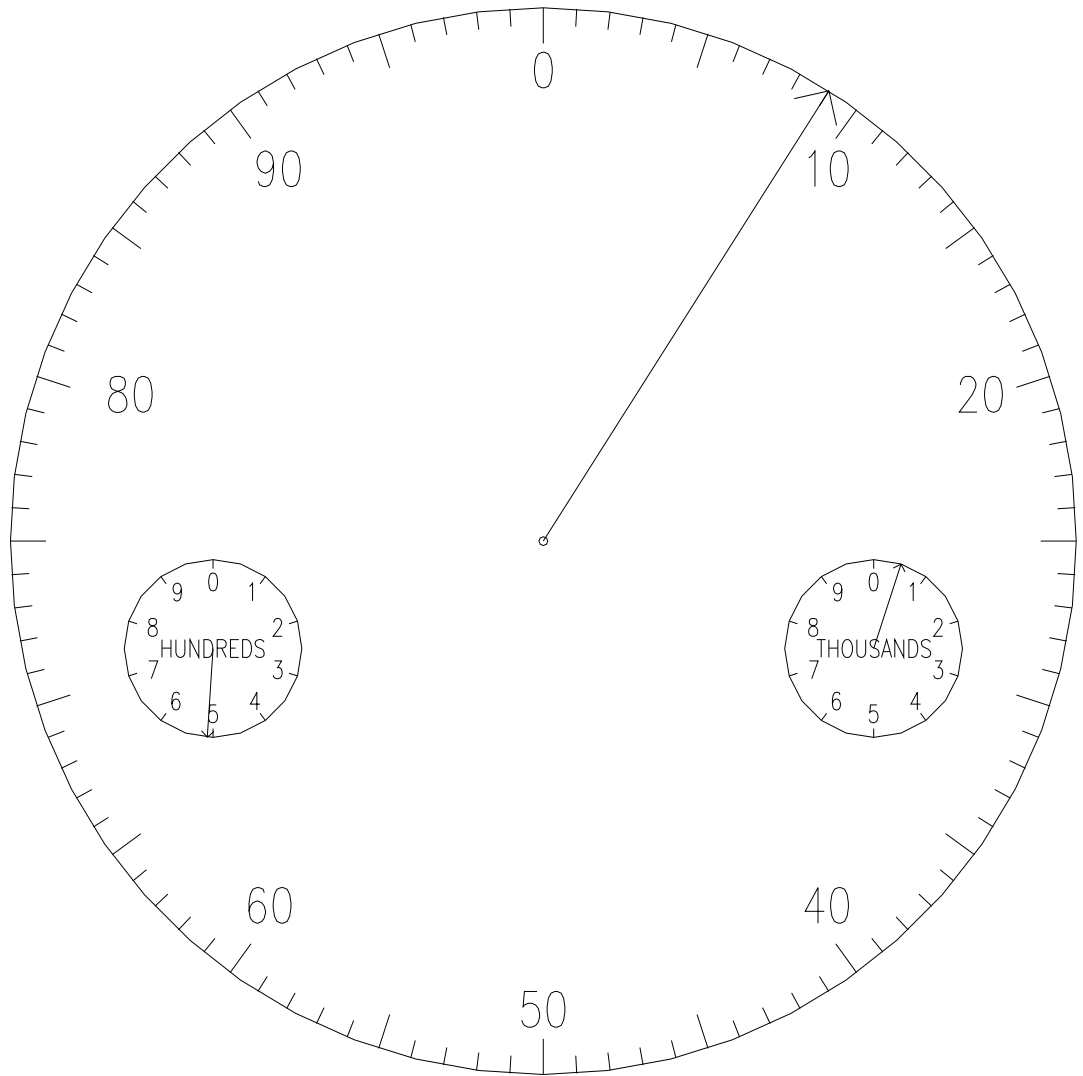

Find The Square Feet

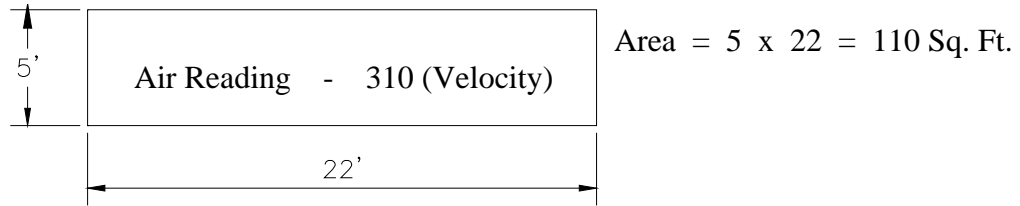

Answer: 34,100 Cu. Ft. Per Minute

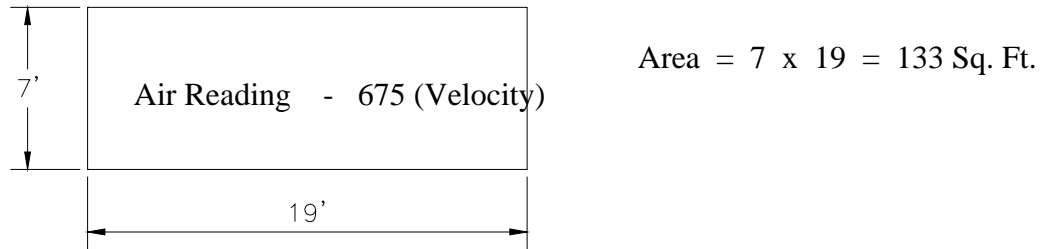

Answer: 89,775 Cu. Ft. Per Minute

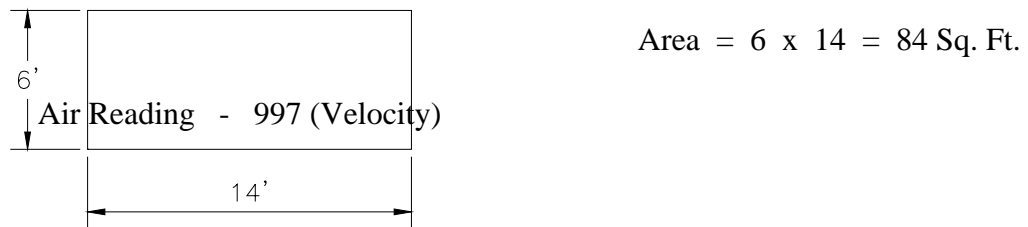

Answer: 83,748 Cu. Ft. Per Minute

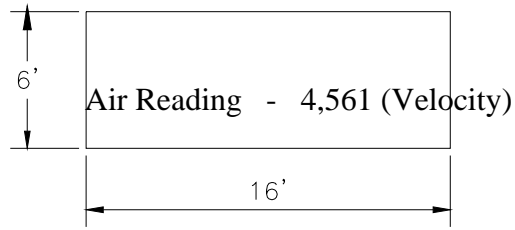

Area = 6 x 16 = 96 Sq. Ft.

Answer: 437,856 Cu. Ft. Per Minute

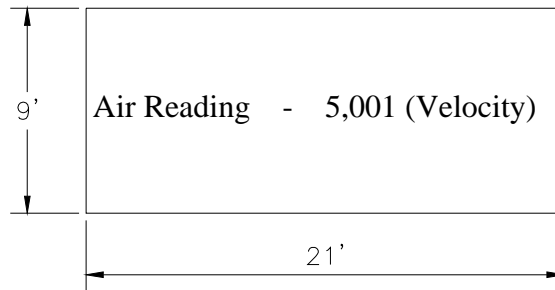

Area = 9 x 21 = 189 Sq. Ft.

Answer: 945,189 Cu. Ft. Per Minute

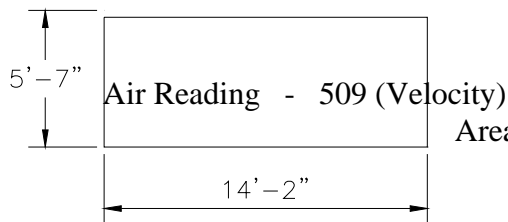

Area = 5.583 x 14.167 = 79.09 Sq. Ft.

Answer: 40,259 Cu Ft. Per Minute

DEFINITIONS OF COAL MINING TERMS

A

Abutment - In coal mining, (1) the weight of the rocks above a narrow roadway is transferred to the solid coal along the sides, which act as abutments of the arch of strata spanning the roadway; and (2) the weight of the rocks over a longwall face is transferred to the front abutment, that is, the solid coal ahead of the face and the back abutment, that is, the settled packs behind the face.

Acid deposition or acid rain – Refers loosely to a mixture of wet and dry "deposition" (deposited material) from the atmosphere containing higher than "normal" amount of nitric and sulfuric acids. The precursors or chemical forerunners of acid rain formation result from both natural sources, such as volcanoes and decaying vegetation, and man-made sources, primarily emissions of sulfur and nitrogen oxides resulting from fossil fuel combustion.

Acid mine water - Mine water that contains free sulfuric acid, mainly due to the weathering of iron pyrites.

Active workings - Any place in a mine where miners are normally required to work or travel and which are ventilated and inspected regularly.

Adit - A nearly horizontal passage from the surface by which a mine is entered and dewatered. A blind horizontal opening into a mountain, with only one entrance.

Advance - Mining in the same direction, or order of sequence; first mining as distinguished from retreat.

Air split - The division of a current of air into two or more parts.

Airway - Any passage through which air is carried. Also known as an air course.

Anemometer - Instrument for measuring air velocity.

Angle of dip - The angle at which strata or mineral deposits are inclined to the horizontal plane.

Angle of draw - In coal mine subsidence, this angle is assumed to bisect the angle between the vertical and the angle of repose of the material and is 20° for flat seams. For dipping seams, the angle of break increases, being 35.8° from the vertical for a 40° dip. The main break occurs over the seam at an angle from the vertical equal to half the dip.

Angle of repose - The maximum angle from horizontal at which a given material will rest on a given surface without sliding or rolling.

Anticline - An upward fold or arch of rock strata.

Aquifer - A water-bearing bed of porous rock, often sandstone.

Arching - Fracture processes around a mine opening, leading to stabilization by an arching effect.

Area (of an airway) - Average width multiplied by average height of airway, expressed in square feet.

Auger - A rotary drill that uses a screw device to penetrate, break, and then transport the drilled material (coal).

Auxiliary operations - All activities supportive of but not contributing directly to mining.

Auxiliary ventilation - Portion of main ventilating current directed to face of dead end entry by means of an auxiliary fan and tubing.

Azimuth - A surveying term that references the angle measured clockwise from any meridian (the established line of reference). The bearing is used to designate direction. The bearing of a line is the acute horizontal angle between the meridian and the line.

B

Back - The roof or upper part in any underground mining cavity.

Backfill – Mine waste or rock used to support the roof after coal removal.

Barren - Said of rock or vein material containing no minerals of value, and of strata without coal, or containing coal in seams too thin to be workable.

Barricading - Enclosing part of a mine to prevent inflow of noxious gasses from a mine fire or an explosion.

Barrier - Something that bars or keeps out. Barrier pillars are solid blocks of coal left between two mines or sections of a mine to prevent accidents due to intrushes of water, gas, or from explosions or a mine fire.

Beam - A bar or straight girder used to support a span of roof between two support props or walls.

Beam building - The creation of a strong, inflexible beam by bolting or otherwise fastening together several weaker layers. In coal mining this is the intended basis for roof bolting.

Bearing – A surveying term used to designate direction. The bearing of a line is the acute horizontal angle between the meridian and the line. The meridian is an established line of reference. Azimuths are angles measured clockwise from any meridian.

Bearing plate - A plate used to distribute a given load. In roof bolting, the plate used between the bolt head and the roof.

Bed - A stratum of coal or other sedimentary deposit.

Belt conveyor - A looped belt on which coal or other materials can be carried and which is generally constructed of flame-resistant material or of reinforced rubber or rubber-like substance.

Belt idler - A roller, usually of cylindrical shape, which is supported on a frame and which, in turn, supports or guides a conveyor belt. Idlers are not powered but turn by contact with the moving belt.

Belt take-up - A belt pulley, generally under a conveyor belt and in by the drive pulley, kept under strong tension parallel to the belt line. Its purpose is to automatically compensate for any slack in the belting created by start-up, etc.

Bench - One of two or more divisions of a coal seam separated by slate or formed by the process of cutting the coal.

Beneficiation - The treatment of mined material, making it more concentrated or richer.

Berm - A pile or mound of material capable of restraining a vehicle.

Binder - A streak of impurity in a coal seam.

Bit - The hardened and strengthened device at the end of a drill rod that transmits the energy of breakage to the rock. The size of the bit determines the size of the hole. A bit may be either detachable from or integral with its supporting drill rod.

Bituminous coal – A middle rank coal (between subbituminous and anthracite) formed by additional pressure and heat on lignite. Usually has a high Btu value and may be referred to as "soft coal."

Black damp - A term generally applied to carbon dioxide. Strictly speaking, it is a mixture of carbon dioxide and nitrogen. It is also applied to an atmosphere depleted of oxygen, rather than having an excess of carbon dioxide.

Blasting agent - Any material consisting of a mixture of a fuel and an oxidizer.

Blasting cap - A detonator containing a charge of detonating compound, which is ignited by electric current or the spark of a fuse. Used for detonating explosives.

Blasting circuit - Electric circuits used to fire electric detonators or to ignite an igniter cord by means of an electric starter.

Bleeder or bleeder entries - Special air courses developed and maintained as part of the mine ventilation system and designed to continuously move air-methane mixtures emitted by the gob or at the active face away from the active workings and into mine-return air courses. Alt: Exhaust ventilation lateral.

Bolt torque - The turning force in foot-pounds applied to a roof bolt to achieve an installed tension.

Borehole - Any deep or long drill-hole, usually associated with a diamond drill.

Bottom - Floor or underlying surface of an underground excavation.

Boss - Any member of the managerial ranks who is directly in charge of miners (e.g., "shift-boss," "face-boss," "fire-boss," etc.).

Box-type magazine - A small, portable magazine used to store limited quantities of explosives or detonators for short periods of time at locations in the mine which are convenient to the blasting sites at which they will be used.

Brattice or brattice cloth - Fire-resistant fabric or plastic partition used in a mine passage to confine the air and force it into the working place. Also termed "line brattice," "line canvas," or "line curtain."

Break line - The line that roughly follows the rear edges of coal pillars that are being mined. The line along which the roof of a coal mine is expected to break.

Breakthrough - A passage for ventilation that is cut through the pillars between rooms.

Bridge carrier - A rubber-tire-mounted mobile conveyor, about 10 meters long, used as an intermediate unit to create a system of articulated conveyors between a mining machine and a room or entry conveyor.

Bridge conveyor - A short conveyor hung from the boom of mining or lading machine or haulage system with the other end attached to a receiving bin that dollies along a frame supported by the room or entry conveyor, tailpiece. Thus, as the machine boom moves, the bridge conveyor keeps it in constant connection with the tailpiece.

Brow - A low place in the roof of a mine, giving insufficient headroom.

Brushing - Digging up the bottom or taking down the top to give more headroom in roadways.

Btu – British thermal unit. A measure of the energy required to raise the temperature of one pound of water one degree Fahrenheit.

Bug dust - The fine particles of coal or other material resulting from the boring or cutting of the coal face by drill or machine.

Bump (or burst) - A violent dislocation of the mine workings which is attributed to severe stresses in the rock surrounding the workings.

Butt cleat - A short, poorly defined vertical cleavage plane in a coal seam, usually at right angles to the long face cleat.

Butt entry - A coal mining term that has different meanings in different locations. It can be synonymous with panel entry, submain entry, or in its older sense it refers to an entry that is "butt" onto the coal cleavage (that is, at right angles to the face).

C

Cage - In a mine shaft, the device, similar to an elevator car, that is used for hoisting personnel and materials.

Calorific value - The quantity of heat that can be liberated from one pound of coal or oil measured in BTU's.

Cannel coal - A massive, non-caking block coal with a fine, even grain and a conchoidal fracture which has a high percentage of hydrogen, burns with a long, yellow flame, and is extremely easy to ignite.

Canopy - A protective covering of a cab on a mining machine.

Cap - A miner's safety helmet. Also, a highly sensitive, encapsulated explosive that is used to detonate larger but less sensitive explosives.

Cap block - A flat piece of wood inserted between the top of the prop and the roof to provide bearing support.

Car - A railway wagon, especially any of the wagons adapted to carrying coal, ore, and waste underground.

Car-dump - The mechanism for unloading a loaded car.

Carbide bit - More correctly, cemented tungsten carbide. A cutting or drilling bit for rock or coal, made by fusing an insert of molded tungsten carbide to the cutting edge of a steel bit shank.

Cast - A directed throw; in strip-mining, the overburden is cast from the coal to the previously mined area.

Certified - Describes a person who has passed an examination to do a required job.

Chain conveyor - A conveyor on which the material is moved along solid pans (troughs) by the action of scraper crossbars attached to powered chains.

Chain pillar - The pillar of coal left to protect the gangway or entry and the parallel airways.

Check curtain - Sheet of brattice cloth hung across an airway to control the passage of the air current.

Chock - Large hydraulic jacks used to support roof in longwall and shortwall mining systems.

Clay vein - A body of clay-like material that fills a void in a coal bed.

Cleat - The vertical cleavage of coal seams. The main set of joints along which coal breaks when mined.

Clean Air Act Amendments of 1990 – A comprehensive set of amendments to the federal law governing the nation's air quality. The Clean Air Act was originally passed in 1970 to address significant air pollution problems in our cities. The 1990 amendments broadened and strengthened the original law to address specific problems such as acid deposition, urban smog, hazardous air pollutants and stratospheric ozone depletion.

Clean Coal Technologies – A number of innovative, new technologies designed to use coal in a more efficient and cost-effective manner while enhancing environmental protection. Several promising technologies include: fluidized-bed combustion, integrated gasification combined cycle, limestone injection multi-stage burner, enhanced flue gas desulfurization (or "scrubbing"), coal liquefaction and coal gasification.

Coal - A solid, brittle, more or less distinctly stratified combustible carbonaceous rock, formed by partial to complete decomposition of vegetation; varies in color from dark brown to black; not fusible without decomposition and very insoluble.

Coal dust - Particles of coal that can pass a No. 20 sieve.

Coal Gasification – The conversion of coal into a gaseous fuel.

Coal mine - An area of land and all structures, facilities, machinery, tools, equipment, shafts, slopes, tunnels, excavations, and other property, real or personal, placed upon, under, or above the surface of such land by any person, used in extracting coal from its natural deposits in the earth by any means or method, and the work of preparing the coal so extracted, including coal preparation facilities. British term is "colliery".

Coal reserves - Measured tonnages of coal that have been calculated to occur in a coal seam within a particular property.

Coal washing – The process of separating undesirable materials from coal based on differences in densities. Pyritic sulfur, or sulfur combined with iron, is heavier and sinks in water; coal is lighter and floats.

Coke – A hard, dry carbon substance produced by heating coal to a very high temperature in the absence of air.

Collar - The term applied to the timbering or concrete around the mouth or top of a shaft. The beginning point of a shaft or drill hole at the surface.

Colliery - British name for coal mine.

Column flotation – A precombustion coal cleaning technology in which coal particles attach to air bubbles rising in a vertical column. The coal is then removed at the top of the column.

Comminution - The breaking, crushing, or grinding of coal, ore, or rock.

Competent rock - Rock which, because of its physical and geological characteristics, is capable of sustaining openings without any structural support except pillars and walls left during mining (stalls, light props, and roof bolts are not considered structural support).

Contact - The place or surface where two different kinds of rocks meet. Applies to sedimentary rocks, as the contact between a limestone and a sandstone, for example, and to metamorphic rocks; and it is especially applicable between igneous intrusions and their walls.

Continuous miner - A machine that constantly extracts coal while it loads it. This is to be distinguished from a conventional, or cyclic, unit which must stop the extraction process in order for loading to commence.

Contour - An imaginary line that connects all points on a surface having the same elevation.

Conventional mining – The first fully-mechanized underground mining method involving the insertion of explosives in a coal seam, the blasting of the seam, and the removal of the coal onto a conveyor or shuttle car by a loading machine.

Conveyor - An apparatus for moving material from one point to another in a continuous fashion. This is accomplished with an endless (that is, looped) procession of hooks, buckets, wide rubber belt, etc.

Core sample – A cylinder sample generally 1-5" in diameter drilled out of an area to determine the geologic and chemical analysis of the overburden and coal.

Cover - The overburden of any deposit.

Creep - The forcing of pillars into soft bottom by the weight of a strong roof. In surface mining, a very slow movement of slopes downhill.

Crib - A roof support of prop timbers or ties, laid in alternate cross-layers, log-cabin style. It may or may not be filled with debris. Also may be called a chock or cog.

Cribbing - The construction of cribs or timbers laid at right angles to each other, sometimes filled with earth, as a roof support or as a support for machinery.

Crop coal - Coal at the outcrop of the seam. It is usually considered of inferior quality due to partial oxidation, although this is not always the case.

Crossbar - The horizontal member of a roof timber set supported by props located either on roadways or at the face.

Crosscut - A passageway driven between the entry and its parallel air course or air courses for ventilation purposes. Also, a tunnel driven from one seam to another through or across the intervening measures; sometimes called "crosscut tunnel", or "breakthrough". In vein mining, an entry perpendicular to the vein.

Cross entry - An entry running at an angle with the main entry.

Crusher - A machine for crushing rock or other materials. Among the various types of crushers are the ball mill, gyratory crusher, Handzel mill, hammer mill, jaw crusher, rod mill, rolls, stamp mill, and tube mill.

Cutter; Cutting machine - A machine, usually used in coal, that will cut a 10- to 15-cm slot. The slot allows room for expansion of the broken coal. Also applies to the man who operates the machine and to workers engaged in the cutting of coal by prick or drill.

Cycle mining - A system of mining in more than one working place at a time, that is, a miner takes a lift from the face and moves to another face while permanent roof support is established in the previous working face.

D

Demonstrated reserves – A collective term for the sum of coal in both measured and indicated resources and reserves.

Deposit - Mineral deposit or ore deposit is used to designate a natural occurrence of a useful mineral, or an ore, in sufficient extent and degree of concentration to invite exploitation.

Depth - The word alone generally denotes vertical depth below the surface. In the case of incline shafts and boreholes it may mean the distance reached from the beginning of the shaft or hole, the borehole depth, or the inclined depth.

Detectors - Specialized chemical or electronic instruments used to detect mine gases.

Detonator - A device containing a small detonating charge that is used for detonating an explosive, including, but not limited to, blasting caps, exploders, electric detonators, and delay electric blasting caps.

Development mining - Work undertaken to open up coal reserves as distinguished from the work of actual coal extraction.

Diffusion - Blending of a gas and air, resulting in a homogeneous mixture. Blending of two or more gases.

Diffuser fan - A fan mounted on a continuous miner to assist and direct air delivery from the machine to the face.

Dilute - To lower the concentration of a mixture; in this case the concentration of any hazardous gas in mine air by addition of fresh intake air.

Dilution - The contamination of ore with barren wall rock in stopping.

Dip - The inclination of a geologic structure (bed, vein, fault, etc.) from the horizontal; dip is always measured downwards at right angles to the strike.

Dragline – A large excavation machine used in surface mining to remove overburden (layers of rock and soil) covering a coal seam. The dragline casts a wire rope-hung bucket a considerable distance, collects the dug material by pulling the bucket toward itself on the ground with a second wire rope (or chain), elevates the bucket, and dumps the material on a spoil bank, in a hopper, or on a pile.

Drainage - The process of removing surplus ground or surface water either by artificial means or by gravity flow.

Draw slate - A soft slate, shale, or rock from approximately 1 cm to 10 cm thick and located immediately above certain coal seams, which falls quite easily when the coal support is withdrawn.

Drift - A horizontal passage underground. A drift follows the vein, as distinguished from a crosscut that intersects it, or a level or gallery, which may do either.

Drift mine – An underground coal mine in which the entry or access is above water level and generally on the slope of a hill, driven horizontally into a coal seam.

Drill - A machine utilizing rotation, percussion (hammering), or a combination of both to make holes. If the hole is much over 0.4m in diameter, the machine is called a borer.

Drilling - The use of such a machine to create holes for exploration or for loading with explosives.

Dummy - A bag filled with sand, clay, etc., used for stemming a charged hole.

Dump - To unload; specifically, a load of coal or waste; the mechanism for unloading, e.g. a car dump (sometimes called tipple); or, the pile created by such unloading, e.g. a waste dump (also called heap, pile, tip, spoil pike, etc.).

E

Electrical grounding - To connect with the ground to make the earth part of the circuit.

Entry - An underground horizontal or near-horizontal passage used for haulage, ventilation, or as a mainway; a coal heading; a working place where the coal is extracted from the seam in the initial mining; same as "gate" and "roadway," both British terms.

Evaluation - The work involved in gaining a knowledge of the size, shape, position and value of coal.

Exploration - The search for mineral deposits and the work done to prove or establish the extent of a mineral deposit. Alt: Prospecting and subsequent evaluation.

Explosive - Any rapidly combustive or expanding substance. The energy released during this rapid combustion or expansion can be used to break rock.

Extraction - The process of mining and removal of cal or ore from a mine.

F

Face – The exposed area of a coal bed from which coal is being extracted.

Face cleat - The principal cleavage plane or joint at right angles to the stratification of the coal seam.

Face conveyor - Any conveyor used parallel to a working face which delivers coal into another conveyor or into a car.

Factor of safety - The ratio of the ultimate breaking strength of the material to the force exerted against it. If a rope will break under a load of 6000 lbs., and it is carrying a load of 2000 lbs., its factor of safety is 6000 divided by 2000 which equals 3.

Fall - A mass of roof rock or coal which has fallen in any part of a mine.

Fan, auxiliary - A small, portable fan used to supplement the ventilation of an individual working place.

Fan, booster - A large fan installed in the main air current, and thus in tandem with the main fan.

Fan signal - Automation device designed to give alarm if the main fan slows down or stops.

Fault - A slip-surface between two portions of the earth's surface that have moved relative to each other. A fault is a failure surface and is evidence of severe earth stresses.

Fault zone - A fault, instead of being a single clean fracture, may be a zone hundreds or thousands of feet wide. The fault zone consists of numerous interlacing small faults or a confused zone of gouge, breccia, or mylonite.

Feeder - A machine that feeds coal onto a conveyor belt evenly.

Fill - Any material that is put back in place of the extracted ore to provide ground support.

Fire damp - The combustible gas, methane, CH₄. Also, the explosive methane-air mixtures with between 5% and 15% methane. A combustible gas formed in mines by decomposition of coal or other carbonaceous matter, and that consists chiefly of methane.

Fissure - An extensive crack, break, or fracture in the rocks.

Fixed carbon – The part of the carbon that remains behind when coal is heated in a closed vessel until all of the volatile matter is driven off.

Flat-lying - Said of deposits and coal seams with a dip up to 5 degrees.

Flight - The metal strap or crossbar attached to the drag chain-and-flight conveyor.

Float dust - Fine coal-dust particles carried in suspension by air currents and eventually deposited in return entries. Dust consisting of particles of coal that can pass through a No. 200 sieve.

Floor - That part of any underground working upon which a person walks or upon which haulage equipment travels; simply the bottom or underlying surface of an underground excavation.

Flue Gas Desulfurization – Any of several forms of chemical/physical processes that remove sulfur compounds formed during coal combustion. The devices, commonly called "scrubbers," combine the sulfur in gaseous emissions with another chemical medium to form inert "sludge" which must then be removed for disposal.

Fluidized Bed Combustion – A process with a high degree of ability to remove sulfur from coal during combustion. Crushed coal and limestone are suspended in the bottom of a boiler by an upward stream of hot air. The coal is burned in this bubbling, liquid-like (or "fluidized") mixture. Rather than released as emissions, sulfur from combustion gases combines with the limestone to form a solid compound recovered with the ash.

Fly ash – The finely divided particles of ash suspended in gases resulting from the combustion of fuel. Electrostatic precipitators are used to remove fly ash from the gases prior to the release from a power plant's smokestack.

Formation – Any assemblage of rocks which have some character in common, whether of origin, age, or composition. Often, the word is loosely used to indicate anything that has been formed or brought into its present shape.

Fossil fuel – Any naturally occurring fuel of an organic nature, such as coal, crude oil and natural gas.

Fracture - A general term to include any kind of discontinuity in a body of rock if produced by mechanical failure, whether by shear stress or tensile stress. Fractures include faults, shears, joints, and planes of fracture cleavage.

Friable - Easy to break, or crumbling naturally. Descriptive of certain rocks and minerals.

Fuse - A cord-like substance used in the ignition of explosives. Black powder is entrained in the cord and, when lit, burns along the cord at a set rate. A fuse can be safely used to ignite a cap, which is the primer for an explosive.

G

Gallery - A horizontal or a nearly horizontal underground passage, either natural or artificial.

Gasification – Any of various processes by which coal is turned into low, medium, or high Btu gases.

Gathering conveyor; gathering belt - Any conveyor which is used to gather coal from other conveyors and deliver it either into mine cars or onto another conveyor. The term is frequently used with belt conveyors placed in entries where a number of room conveyors deliver coal onto the belt.

Geologist - One who studies the constitution, structure, and history of the earth's crust, conducting research into the formation and dissolution of rock layers, analyzing fossil and mineral content of layers, and endeavoring to fix historical sequence of development by relating characteristics to known geological influences (historical geology).

Gob - The term applied to that part of the mine from which the coal has been removed and the space more or less filled up with waste. Also, the loose waste in a mine. Also called goaf.

Grain - In petrology, that factor of the texture of a rock composed of distinct particles or crystals which depends upon their absolute size.

Grizzly - Course screening or scalping device that prevents oversized bulk material from entering a material transfer system; constructed of rails, bars, beams, etc.

Ground control - The regulation and final arresting of the closure of the walls of a mined area. The term generally refers to measures taken to prevent roof falls or coal bursts.

Ground pressure - The pressure to which a rock formation is subjected by the weight of the superimposed rock and rock material or by diastrophic forces created by movements in the rocks forming the earth's crust. Such pressures may be great enough to cause rocks having a low compressional strength to deform and be squeezed into and close a borehole or other underground opening not adequately strengthened by an artificial support, such as casing or timber.

Gunite - A cement applied by spraying to the roof and sides of a mine passage.

H

Haulage - The horizontal transport of ore, coal, supplies, and waste. The vertical transport of the same is called hoisting.

Haulageway - Any underground entry or passageway that is designed for transport of mined material, personnel, or equipment, usually by the installation of track or belt conveyor.

Headframe - The structure surmounting the shaft which supports the hoist rope pulley, and often the hoist itself.

Heading - A vein above a drift. An interior level or airway driven in a mine. In longwall workings, a narrow passage driven upward from a gangway in starting a working in order to give a loose end.

Head section - A term used in both belt and chain conveyor work to designate that portion of the conveyor used for discharging material.

Heaving - Applied to the rising of the bottom after removal of the coal; a sharp rise in the floor is called a "hogsback".

Highwall - The unexcavated face of exposed overburden and coal in a surface mine or in a face or bank on the uphill side of a contour mine excavation.

Highwall miner – A highwall mining system consists of a remotely controlled continuous miner which extracts coal and conveys it via augers, belt or chain conveyors to the outside. The cut is typically a rectangular, horizontal cut from a highwall bench, reaching depths of several hundred feet or deeper.

Hogsback - A sharp rise in the floor of a seam.

Hoist - A drum on which hoisting rope is wound in the engine house, as the cage or skip is raised in the hoisting shaft.

Hoisting - The vertical transport coal or material.

Horizon - In geology, any given definite position or interval in the stratigraphic column or the scheme of stratigraphic classification; generally used in a relative sense.

Horseback - A mass of material with a slippery surface in the roof; shaped like a horse's back.

Hydraulic - Of or pertaining to fluids in motion. Hydraulic cement has a composition which permits it to set quickly under water. Hydraulic jacks lift through the force transmitted to the movable part of the jack by a liquid. Hydraulic control refers to the mechanical control of various parts of machines, such as coal cutters, loaders, etc., through the operation or action of hydraulic cylinders.

Hydrocarbon – A family of chemical compounds containing carbon and hydrogen atoms in various combinations, found especially in fossil fuels.

I

Inby - In the direction of the working face.

Incline - Any entry to a mine that is not vertical (shaft) or horizontal (adit). Often incline is reserved for those entries that are too steep for a belt conveyor (+17 degrees -18 degrees), in which case a hoist and guide rails are employed. A belt conveyor incline is termed a slope. Alt: Secondary inclined opening, driven upward to connect levels, sometimes on the dip of a deposit; also called "inclined shaft".

Incompetent - Applied to strata, a formation, a rock, or a rock structure not combining sufficient firmness and flexibility to transmit a thrust and to lift a load by bending.

Indicated coal resources – Coal for which estimates of the rank, quality, and quantity have been computed partly from sample analyses and measurements and partly from reasonable geologic projections. The points of observation are ½ to 1 ½ miles apart. Indicated coal is projected to extend as an ½ mile wide belt that lies more than ¼ mile from the outcrop or points of observation or measurement.

Inferred coal resources – Coal in unexplored extensions of the demonstrated resources for which estimates of the quality and size are based on geologic evidence and projection. Quantitative estimates are based largely on broad knowledge of the geologic character of the deposit and for which there are few, if any, samples or measurements. The estimates are based

on an assumed continuity or repletion of which there is geologic evidence; this evidence may include comparison with deposits of similar type. Bodies that are completely concealed may be included if there is specific geologic evidence of their presence. The points of observation are 1 ½ to 6 miles apart.

In situ - In the natural or original position. Applied to a rock, soil, or fossil when occurring in the situation in which it was originally formed or deposited.

Intake - The passage through which fresh air is drawn or forced into a mine or to a section of a mine.

Intermediate section - A term used in belt and chain conveyor network to designate a section of the conveyor frame occupying a position between the head and foot sections.

Immediate roof - The roof strata immediately above the coalbed, requiring support during the excavation of coal.

Isopach - A line, on a map, drawn through points of equal thickness of a designated unit. Synonym for isopachous line; isopachyte.

J

Jackleg - A percussion drill used for drifting or stopping that is mounted on a telescopic leg which has an extension of about 2.5 m. The leg and machine are hinged so that the drill need not be in the same direction as the leg.

Jackrock – A caltrop or other object manufactured with one or more rounded or sharpened points, which when placed or thrown present at least one point at such an angle that it is peculiar to and designed for use in puncturing or damaging vehicle tires. Jackrocks are commonly used during labor disputes.

Job Safety Analysis (J.S.A.) - A job breakdown that gives a safe, efficient job procedure.

Joint - A divisional plane or surface that divides a rock and along which there has been no visible movement parallel to the plane or surface.

K

Kettle bottom - A smooth, rounded piece of rock, cylindrical in shape, which may drop out of the roof of a mine without warning. The origin of this feature is thought to be the remains of the stump of a tree that has been replaced by sediments so that the original form has been rather well preserved.

Kerf - The undercut of a coal face.

L

Lamp - The electric cap lamp worn for visibility. Also, the flame safety lamp used in coal mines to detect methane gas concentrations and oxygen deficiency.

Layout - The design or pattern of the main roadways and workings. The proper layout of mine workings is the responsibility of the manager aided by the planning department.

Lift - The amount of coal obtained from a continuous miner in one mining cycle.

Liquefaction – The process of converting coal into a synthetic fuel, similar in nature to crude oil and/or refined products, such as gasoline.

Lithology - The character of a rock described in terms of its structure, color, mineral composition, grain size, and arrangement of its component parts; all those visible features that in the aggregate impart individuality of the rock. Lithology is the basis of correlation in coal mines and commonly is reliable over a distance of a few miles.

Load - To place explosives in a drill hole. Also, to transfer broken material into a haulage device.

Loading machine - Any device for transferring excavated coal into the haulage equipment.

Loading pocket - Transfer point at a shaft where bulk material is loaded by bin, hopper, and chute into a skip.

Longwall Mining – One of three major underground coal mining methods currently in use. Employs a steel plow, or rotation drum, which is pulled mechanically back and forth across a face of coal that is usually several hundred feet long. The loosened coal falls onto a conveyor for removal from the mine.

Loose coal - Coal fragments larger in size than coal dust.

Low voltage - Up to and including 660 volts by federal standards.

M

Main entry - A main haulage road. Where the coal has cleats, main entries are driven at right angles to the face cleats.

Main fan - A mechanical ventilator installed at the surface; operates by either exhausting or blowing to induce airflow through the mine roadways and workings.

Manhole - A safety hole constructed in the side of a gangway, tunnel, or slope in which miner can be safe from passing locomotives and car. Also called a refuge hole.

Man trip - A carrier of mine personnel, by rail or rubber tire, to and from the work area.

Manway - An entry used exclusively for personnel to travel from the shaft bottom or drift mouth to the working section; it is always on the intake air side in gassy mines. Also, a small passage at one side or both sides of a breast, used as a traveling way for the miner, and sometimes, as an airway, or chute, or both.

Measured coal resources – Coal for which estimates of the rank, quality, and quantity have been computed from sample analyses and measurements from closely spaced and geologically well-known sample sites, such as outcrops, trenches, mine workings, and drill holes. The points of observation and measurement are so closely spaced and the thickness and extent of coals are so well defined that the tonnage is judged to be accurate within 20 percent of true tonnage. Although the spacing of the points of observation necessary to demonstrate continuity of the coal differs from region to region according to the character of the coal beds, the points of observation are no greater than ½ mile apart. Measured coal is projected to extend as a ¼-mile wide belt from the outcrop or points of observation or measurement.

Meridian — A surveying term that establishes a line of reference. The bearing is used to designate direction. The bearing of a line is the acute horizontal angle between the meridian and the line. Azimuths are angles measured clockwise from any meridian.

Methane – A potentially explosive gas formed naturally from the decay of vegetative matter, similar to that which formed coal. Methane, which is the principal component of natural gas, is frequently encountered in underground coal mining operations and is kept within safe limits through the use of extensive mine ventilation systems.

Methane monitor - An electronic instrument often mounted on a piece of mining equipment, that detects and measures the methane content of mine air.

Mine development - The term employed to designate the operations involved in preparing a mine for ore extraction. These operations include tunneling, sinking, cross-cutting, drifting, and raising.

Mine mouth electric plant – A coal burning electric-generating plant built near a coal mine.

Miner - One who is engaged in the business or occupation of extracting ore, coal, precious substances, or other natural materials from the earth's crust.

Mineral - An inorganic compound occurring naturally in the earth's crust, with a distinctive set of physical properties, and a definite chemical composition.

Mining Engineer - A person qualified by education, training, and experience in mining engineering. A trained engineer with knowledge of the science, economics, and arts of mineral location, extraction, concentration and sale, and the administrative and financial problems of practical importance in connection with the profitable conduct of mining.

Misfire - The complete or partial failure of a blasting charge to explode as planned.

MSHA - Mine Safety and Health Administration; the federal agency which regulates coal mine health and safety.

Mud cap - A charge of high explosive fired in contact with the surface of a rock after being covered with a quantity of wet mud, wet earth, or sand, without any borehole being used. Also termed adobe, dobie, and sandblast (illegal in coal mining).

Natural ventilation - Ventilation of a mine without the aid of fans or furnaces.

Nip - Device at the end of the trailing cable of a mining machine used for connecting the trailing cable to the trolley wire and ground.

O

Open end pillaring - A method of mining pillars in which no stump is left; the pockets driven are open on the gob side and the roof is supported by timber.

Outby; outbye - Nearer to the shaft, and hence farther from the working face. Toward the mine entrance. The opposite of inby.

Outcrop – Coal that appears at or near the surface.

Overburden – Layers of soil and rock covering a coal seam. Overburden is removed prior to surface mining and replaced after the coal is taken from the seam.

Overcast (undercast) - Enclosed airway which permits one air current to pass over (under) another without interruption.

P

Panel - A coal mining block that generally comprises one operating unit.

Panic bar - A switch, in the shape of a bar, used to cut off power at the machine in case of an emergency.

Parting - (1) A small joint in coal or rock; (2) a layer of rock in a coal seam; (3) a side track or turnout in a haulage road.

Peat – The partially decayed plant matter found in swamps and bogs, one of the earliest stages of coal formation.

Percentage extraction - The proportion of a coal seam which is removed from the mine. The remainder may represent coal in pillars or coal which is too thin or inferior to mine or lost in mining. Shallow coal mines working under townships, reservoirs, etc., may extract 50%, or less, of the entire seam, the remainder being left as pillars to protect the surface. Under favorable conditions, longwall mining may extract from 80 to 95% of the entire seam. With pillar methods of working, the extraction ranges from 50 to 90% depending on local conditions.

Percussion drill - A drill, usually air powered, that delivers its energy through a pounding or hammering action.

Permissible - That which is allowable or permitted. It is most widely applied to mine equipment and explosives of all kinds which are similar in all respects to samples that have passed certain tests of the MSHA and can be used with safety in accordance with specified conditions where hazards from explosive gas or coal dust exist.

Permit – As it pertains to mining, a document issued by a regulatory agency that gives approval for mining operations to take place.

Piggy-back - A bridge conveyor.

Pillar - An area of coal left to support the overlying strata in a mine; sometimes left permanently to support surface structures.

Pillar robbing - The systematic removal of the coal pillars between rooms or chambers to regulate the subsidence of the roof. Also termed "bridging back" the pillar, "drawing" the pillar, or "pulling" the pillar.

Pinch - A compression of the walls of a vein or the roof and floor of a coal seam so as to "squeeze" out the coal.

Pinch – A compression of the roof and floor of a coal seam so as to "squeeze" out the coal.

Pinning - Roof bolting.

Pitch - The inclination of a seam; the rise of a seam.

Plan - A map showing features such as mine workings or geological structures on a horizontal plane.

Pneumoconiosis - A chronic disease of the lung arising from breathing coal dust.

Portal - The structure surrounding the immediate entrance to a mine; the mouth of an adit or tunnel.

Portal bus - Track-mounted, self-propelled personnel carrier that holds 8 to 12 people.

Post - The vertical member of a timber set.

Preparation plant - A place where coal is cleaned, sized, and prepared for market.

Primary roof - The main roof above the immediate top. Its thickness may vary from a few to several thousand feet.

Primer (booster) - A package or cartridge of explosive which is designed specifically to transmit detonation to other explosives and which does not contain a detonator.

Prop - Coal mining term for any single post used as roof support. Props may be timber or steel; if steel--screwed, yieldable, or hydraulic.

Proximate analysis - A physical, or non-chemical, test of the constitution of coal. Not precise, but very useful for determining the commercial value. Using the same sample (1 gram) under controlled heating at fixed temperatures and time periods, moisture, volatile matter, fixed carbon and ash content are successfully determined. Sulfur and Btu content are also generally reported with a proximate analysis.

Pyrite - A hard, heavy, shiny, yellow mineral, FeS₂ or iron disulfide, generally in cubic crystals. Also called iron pyrites, fool's gold, and sulfur balls. Iron pyrite is the most common sulfide found in coal mines.

R

Raise - A secondary or tertiary inclined opening, vertical or near-vertical opening driven upward from a level to connect with the level above, or to explore the ground for a limited distance above one level.

Ramp - A secondary or tertiary inclined opening, driven to connect levels, usually driven in a downward direction, and used for haulage.

Ranks of coal – The classification of coal by degree of hardness, moisture and heat content. "Anthracite" is hard coal, almost pure carbon, used mainly for heating homes. "Bituminous" is soft coal. It is the most common coal found in the United States and is used to generate electricity and to make coke for the steel industry. "Subbituminous" is a coal with a heating value between bituminous and lignite. It has low fixed carbon and high percentages of volatile matter and moisture. "Lignite" is the softest coal and has the highest moisture content. It is used for generating electricity and for conversion into synthetic gas. In terms of Btu or "heating" content, anthracite has the highest value, followed by bituminous, subbituminous and lignite.

Reclamation – The restoration of land and environmental values to a surface mine site after the coal is extracted. Reclamation operations are usually underway as soon as the coal has been removed from a mine site. The process includes restoring the land to its approximate original appearance by restoring topsoil and planting native grasses and ground covers.

Recovery - The proportion or percentage of coal or ore mined from the original seam or deposit.

Red dog - A nonvolatile combustion product of the oxidation of coal or coal refuse. Most commonly applied to material resulting from in situ, uncontrolled burning of coal or coal refuse piles. It is similar to coal ash.

Regulator - Device (wall, door) used to control the volume of air in an air split.

Reserve – That portion of the identified coal resource that can be economically mined at the time of determination. The reserve is derived by applying a recovery factor to that component of the identified coal resource designated as the reserve base.

Resin bolting - A method of permanent roof support in which steel rods are grouted with resin.

Resources – Concentrations of coal in such forms that economic extraction is currently or may become feasible. Coal resources broken down by identified and undiscovered resources. Identified coal resources are classified as demonstrated and inferred. Demonstrated resources are further broken down as measured and indicated. Undiscovered resources are broken down as hypothetical and speculative.

Respirable dust - Dust particles 5 microns or less in size.

Respirable dust sample - A sample collected with an approved coal mine dust sampler unit attached to a miner, or so positioned as to measure the concentration of respirable dust to which the miner is exposed, and operated continuously over an entire work shift of such miner.

Retreat mining - A system of robbing pillars in which the robbing line, or line through the faces of the pillars being extracted, retreats from the boundary toward the shaft or mine mouth.

Return - The air or ventilation that has passed through all the working faces of a split.

Return idler - The idler or roller underneath the cover or cover plates on which the conveyor belt rides after the load which it was carrying has been dumped at the head section and starts the return trip toward the foot section.

Rib - The side of a pillar or the wall of an entry. The solid coal on the side of any underground passage. Same as rib pillar.

Rider - A thin seam of coal overlying a thicker one.

Ripper - A coal extraction machine that works by tearing the coal from the face.

Rob - To extract pillars of coal previously left for support.

Robbed out area - Describes that part of a mine from which the pillars have been removed.

Roll - (1) A high place in the bottom or a low place in the top of a mine passage, (2) a local thickening of roof or floor strata, causing thinning of a coal seam.

Roll protection - A framework, safety canopy, or similar protection for the operator when equipment overturns.

Roof - The stratum of rock or other material above a coal seam; the overhead surface of a coal working place. Same as "back" or "top."

Roof bolt - A long steel bolt driven into the roof of underground excavations to support the roof, preventing and limiting the extent of roof falls. The unit consists of the bolt (up to 4 feet long), steel plate, expansion shell, and pal nut. The use of roof bolts eliminates the need for timbering by fastening together, or "laminating," several weaker layers of roof strata to build a "beam."

Roof fall - A coal mine cave-in especially in permanent areas such as entries.

Roof jack - A screw- or pump-type hydraulic extension post made of steel and used as temporary roof support.

Roof sag - The sinking, bending, or curving of the roof, especially in the middle, from weight or pressure.

Roof stress - Unbalanced internal forces in the roof or sides, created when coal is extracted.

Roof support – Posts, jacks, roof bolts and beams used to support the rock overlying a coal seam in an underground mine. A good roof support plan is part of mine safety and coal extraction.

Roof trusses - A combination of steel rods anchored into the roof to create zones of compression and tension forces and provide better support for weak roof and roof over wide areas.

Room and pillar mining – A method of underground mining in which approximately half of the coal is left in place to support the roof of the active mining area. Large "pillars" are left while "rooms" of coal are extracted.

Room neck - The short passage from the entry into a room.

Round - Planned pattern of drill holes fired in sequence in tunneling, shaft sinking, or stopping. First the cut holes are fired, followed by relief, lifter, and rib holes.

Royalty - The payment of a certain stipulated sum on the mineral produced.

Rubbing surface - The total area (top, bottom, and sides) of an airway.

Run-of-mine - Raw material as it exists in the mine; average grade or quality.

S

Safety fuse - A train of powder enclosed in cotton, jute yarn, or waterproofing compounds, which burns at a uniform rate; used for firing a cap containing the detonation compound which in turn sets off the explosive charge.

Safety lamp - A lamp with steel wire gauze covering every opening from the inside to the outside so as to prevent the passage of flame should explosive gas be encountered.

Sampling - Cutting a representative part of an ore (or coal) deposit, which should truly represent its average value.

Sandstone - A sedimentary rock consisting of quartz sand united by some cementing material, such as iron oxide or calcium carbonate.

Scaling - Removal of loose rock from the roof or walls. This work is dangerous and a long bar (called a scaling bar) is often used.

Scoop - A rubber tired-, battery- or diesel-powered piece of equipment designed for cleaning runways and hauling supplies.

Scrubber – Any of several forms of chemical/physical devices that remove sulfur compounds formed during coal combustion. These devices, technically know as flue gas desulfurization systems, combine the sulfur in gaseous emissions with another chemical medium to form inert "sludge," which must then be removed for disposal.

Seam - A stratum or bed of coal.

Secondary roof - The roof strata immediately above the coalbed, requiring support during the excavating of coal.

Section - A portion of the working area of a mine.

Selective mining - The object of selective mining is to obtain a relatively high-grade mine product; this usually entails the use of a much more expensive stopping system and high exploration and development costs in searching for and developing the separate bunches, stringers, lenses, and bands of ore.

Self-contained breathing apparatus - A self-contained supply of oxygen used during rescue work from coal mine fires and explosions; same as SCSR (self-contained self rescuer).

Self-rescuer – A small filtering device carried by a coal miner underground, either on his belt or in his pocket, to provide him with immediate protection against carbon monoxide and smoke in case of a mine fire or explosion. It is a small canister with a mouthpiece directly attached to it. The wearer breathes through the mouth, the nose being closed by a clip. The canister contains a layer of fused calcium chloride that absorbs water vapor from the mine air. The device is used for escape purposes only because it does not sustain life in atmospheres containing deficient oxygen. The length of time a self-rescuer can be used is governed mainly by the humidity in the mine air, usually between 30 minutes and one hour.

Severance – The separation of a mineral interest from other interests in the land by grant or reservation. A mineral deed or grant of the land reserving a mineral interest, by the landowner before leasing, accomplishes a severance as does his execution of a mineral lease.

Shaft - A primary vertical or non-vertical opening through mine strata used for ventilation or drainage and/or for hoisting of personnel or materials; connects the surface with underground workings.

Shaft mine – An underground mine in which the main entry or access is by means of a vertical shaft.

Shale - A rock formed by consolidation of clay, mud, or silt, having a laminated structure and composed of minerals essentially unaltered since deposition.

Shearer - A mining machine for longwall faces that uses a rotating action to "shear" the material from the face as it progresses along the face.

Shift - The number of hours or the part of any day worked.

Shortwall – An underground mining method in which small areas are worked (15 to 150 feet) by a continuous miner in conjunction with the use of hydraulic roof supports.

Shuttle car – A self-discharging truck, generally with rubber tires or caterpillar-type treads, used for receiving coal from the loading or mining machine and transferring it to an underground loading point, mine railway or belt conveyor system.

Sinking - The process by which a shaft is driven.

Skid - A track-mounted vehicle used to hold trips or cars from running out of control. Also it is a flat-bottom personnel or equipment carrier used in low coal.

Skip - A car being hoisted from a slope or shaft.

Slack - Small coal; the finest-sized soft coal, usually less than one inch in diameter.

Slag - The waste product of the process of smelting.

Slate - A miner's term for any shale or slate accompanying coal. Geologically, it is a dense, fine-textured, metamorphic rock, which has excellent parallel cleavage so that it breaks into thin plates or pencil-like shapes.

Slate bar - The proper long-handled tool used to pry down loose and hazardous material from roof, face, and ribs.

Slickenside - A smooth, striated, polished surface produced on rock by friction.

Slip - A fault. A smooth joint or crack where the strata have moved on each other.

Slope - Primary inclined opening, connection the surface with the underground workings.

Slope mine – An underground mine with an opening that slopes upward or downward to the coal seam.

Sloughing - The slow crumbling and falling away of material from roof, rib, and face.

Solid - Mineral that has not been undermined, sheared out, or otherwise prepared for blasting.

Sounding - Knocking on a roof to see whether it is sound and safe to work under.

Spad – A spad is a flat spike hammered into a wooden plug anchored in a hole drilled into the mine ceiling from which is threaded a plumbline. The spad is an underground survey station similar to the use of stakes in marking survey points on the surface. A pointer spad, or sight spad, is a station that allows a mine foreman to visually align entries or breaks from the main spad.

Span - The horizontal distance between the side supports or solid abutments along sides of a roadway.

Specific gravity - The weight of a substance compared with the weight of an equal volume of pure water at 4 degrees Celsius.

Split - Any division or branch of the ventilating current. Also, the workings ventilated by one branch. Also, to divide a pillar by driving one or more roads through it.

Squeeze - The settling, without breaking, of the roof and the gradual upheaval of the floor of a mine due to the weight of the overlying strata.

Steeply inclined - Said of deposits and coal seams with a dip of from 0.7 to 1 rad (40 degrees to 60 degrees).

Stemming - The noncombustible material used on top or in front of a charge or explosive.

Strike - The direction of the line of intersection of a bed or vein with the horizontal plane. The strike of a bed is the direction of a straight line that connects two points of equal elevation on the bed.

Stripping ratio – The unit amount of overburden that must be removed to gain access to a similar unit amount of coal or mineral material.

Stump - Any small pillar.

Subbituminous – Coal of a rank intermediate between lignite and bituminous.

Subsidence – The gradual sinking, or sometimes abrupt collapse, of the rock and soil layers into an underground mine. Structures and surface features above the subsidence area can be affected.

Sump - The bottom of a shaft, or any other place in a mine, that is used as a collecting point for drainage water.

Sumping - To force the cutter bar of a machine into or under the coal. Also called a sumping cut, or sumping in.

Support - The all-important function of keeping the mine workings open. As a verb, it refers to this function; as a noun it refers to all the equipment and materials--timber, roof bolts, concrete, steel, etc.--that are used to carry out this function.

Surface mine – A mine in which the coal lies near the surface and can be extracted by removing the covering layers of rock and soil.

Suspension - Weaker strata hanging from stronger, overlying strata by means of roof bolts.

Syncline - A fold in rock in which the strata dip inward from both sides toward the axis. The opposite of anticline.

T

Tailgate - A subsidiary gate road to a conveyor face as opposed to a main gate. The tailgate commonly acts as the return airway and supplies road to the face.

Tailpiece - Also known as foot section pulley. The pulley or roller in the tail or foot section of a belt conveyor around which the belt runs.

Tail section - A term used in both belt and chain conveyor work to designate that portion of the conveyor at the extreme opposite end from the delivery point. In either type of conveyor it consists of a frame and either a sprocket or a drum on which the chain or belt travels, plus such other devices as may be required for adjusting belt or chain tension.

Tension - The act of stretching.

Tertiary - Lateral or panel openings (e.g., ramp, crosscut).

Through-steel - A system of dust collection from rock or roof drilling. The drill steel is hollow, and a vacuum is applied at the base, pulling the dust through the steel and into a receptacle on the machine.

Timber - A collective term for underground wooden supports.

Timbering - The setting of timber supports in mine workings or shafts for protection against falls from roof, face, or rib.

Timber set - A timber frame to support the roof, sides, and sometimes the floor of mine roadways or shafts.

Tipple - Originally the place where the mine cars were tipped and emptied of their coal, and still used in that same sense, although now more generally applied to the surface structures of a mine, including the preparation plant and loading tracks.

Ton - A short or net ton is equal to 2,000 pounds; a long or British ton is 2,240 pounds; a metric ton is approximately 2,205 pounds.

Top - A mine roof; same as "back."

Torque wrench - A wrench that indicates, as on a dial, the amount of torque (in units of foot-pounds) exerted in tightening a roof bolt.

Tractor - A battery-operated piece of equipment that pulls trailers, skids, or personnel carriers. Also used for supplies.

Tram - Used in connection with moving self-propelled mining equipment. A tramming motor may refer to an electric locomotive used for hauling loaded trips or it may refer to the motor in a cutting machine that supplies the power for moving or tramming the machine.

Transfer - A vertical or inclined connection between two or more levels and used as an ore pass.

Transfer point - Location in the materials handling system, either haulage or hoisting, where bulk material is transferred between conveyances.

Trip - A train of mine cars.

Troughing idlers - The idlers, located on the upper framework of a belt conveyor, which support the loaded belt. They are so mounted that the loaded belt forms a trough in the direction of travel, which reduces spillage and increases the carrying capacity of a belt for a given width.

Tunnel - A horizontal, or near-horizontal, underground passage, entry, or haulageway, that is open to the surface at both ends. A tunnel (as opposed to an adit) must pass completely through a hill or mountain.

U

Ultimate analysis - Precise determination, by chemical means, of the elements and compounds in coal.

Undercut - To cut below or undermine the coal face by chipping away the coal by pick or mining machine. In some localities the terms "undermine" or "underhole" are used.

Underground mine – Also known as a "deep" mine. Usually located several hundred feet below the earth's surface, an underground mine's coal is removed mechanically and transferred by shuttle car or conveyor to the surface.

Underground station - An enlargement of an entry, drift, or level at a shaft at which cages stop to receive and discharge cars, personnel, and material. An underground station is any location where stationary electrical equipment is installed. This includes pump rooms, compressor rooms, hoist rooms, battery-charging rooms, etc.

Unit train – A long train of between 60 and 150 or more hopper cars, carrying only coal between a single mine and destination.

Universal coal cutter - A type of coal cutting machine which is designed to make horizontal cuts in a coal face at any point between the bottom and top or to make shearing cuts at any point between the two ribs of the place. The cutter bar can be twisted to make cuts at any angle to the horizontal or vertical.

Upcast shaft - A shaft through which air leaves the mine.

V

Valuation - The act or process of valuing or of estimating the value or worth; appraisal.

Velocity - Rate of airflow in lineal feet per minute.

Ventilation - The provision of a directed flow of fresh and return air along all underground roadways, traveling roads, workings, and service parts.

Violation - The breaking of any state or federal mining law.

Virgin - Unworked; untouched; often said of areas where there has been no coal mining.

Void - A general term for pore space or other reopenings in rock. In addition to pore space, the term includes vesicles, solution cavities, or any openings either primary or secondary.

Volatile matter - The gaseous part, mostly hydrocarbons, of coal.

W

Waste - That rock or mineral which must be removed from a mine to keep the mining scheme practical, but which has no value.

Water Gauge (standard U-tube) - Instrument that measures differential pressures in inches of water.

Wedge - A piece of wood tapering to a thin edge and used for tightening in conventional timbering.

Weight - Fracturing and lowering of the roof strata at the face as a result of mining operations, as in "taking weight".

White damp - Carbon monoxide, CO. A gas that may be present in the afterdamp of a gas- or coal-dust explosion, or in the gases given off by a mine fire; also one of the constituents of the gases produced by blasting. Rarely found in mines under other circumstances. It is absorbed by the hemoglobin of the blood to the exclusion of oxygen. One-tenth of 1% (.001) may be fatal in 10 minutes.

Width - The thickness of a lode measured at right angles to the dip.

Winning - The excavation, loading, and removal of coal or ore from the ground; winning follows development.

Winze - Secondary or tertiary vertical or near-vertical opening sunk from a point inside a mine for the purpose of connecting with a lower level or of exploring the ground for a limited depth below a level.

Wire rope - A steel wire rope used for winding in shafts and underground haulages. Wire ropes are made from medium carbon steels. Various constructions of wire rope are designated by the number of strands in the rope and the number of wires in each strand. The following are some common terms encountered: airplane strand; cablelaid rope; cane rope; elevator rope; extra-flexible hoisting rope; flat rope; flattened-strand rope; guy rope; guy strand; hand rope; haulage rope; hawser; hoisting rope; lang lay rope; lay; left lay rope; left twist; nonspinning rope; regular lay; reverse-laid rope; rheostat rope; right lay; right twist; running rope; special flexible hoisting rope; standing rope; towing hawser; transmission rope.

Working - When a coal seam is being squeezed by pressure from roof and floor, it emits creaking noises and is said to be "working". This often serves as a warning to the miners that additional support is needed.

Working face - Any place in a mine where material is extracted during a mining cycle.

Working place - From the outby side of the last open crosscut to the face.

Workings - The entire system of openings in a mine for the purpose of exploitation.

Working section - From the faces to the point where coal is loaded onto belts or rail cars to begin its trip to the outside.

Glossary developed from materials provided by: [Kentucky Mining Institute](#).

INSTRUMENTS AND DEFINITIONS

Questions for Review

Q: What is kettle bottom?

Q: What is a barometer used for?

Q: What is a borehole?

Q: What is cribbing used for?

Q: What is an anemometer?

Q: What is a purpose of timbering?

Q: What are props constructed of?

Q: How do you find rubbing surface?

Q: What is the purpose of a torque wrench?

Q: What are the two types of “Main Mine Fans”?

Q: What is the definition of “certified”?

Q: If someone asks you the velocity of a current, what is the measurement they want to know?

Q: What is a self rescuer?

Q: Where is the working face?

Q: What is White Damp?

Q: What is the definition of coal dust?

Q: What is a water gauge used for?

Q: What is considered “loose coal”?

Q: What is a scrubber used for?

Q: What is a scoop?

Q: What is the purpose of a fan signal?

Q: What is a “robbed out area”?

CHAPTER SEVEN

BLASTING AND EXPLOSIVES

1. Coal Blasting
2. Definitions of Blasting Terms
3. Code of Federal Regulations Part 75 – Subpart N
4. Questions and Review

BLASTING AND EXPLOSIVES



COAL BLASTING

Blasting is an important part of most mining operations. Between 1978 and 2000, 106 miners were killed and 1,050 were injured by explosives and breaking agents. Through the efforts of government, mine operators, labor, and academia, these numbers have been significantly reduced. In 2001, there were 7 blasting-related injuries and fatalities in the mining industry, compared to 140 in 1978. While blasting has become safer, accidents still occur so continued vigilance is needed. For the past two decades, most explosives-related injuries and fatalities in surface mines occurred when workers were struck by rock, either because they were too close to the blast or rock was thrown much farther than expected. The second leading cause was blasts that shoot prematurely. In underground mines, most explosive-related fatalities were caused by miners being too close to the blast, followed by explosive fumes poisoning, misfires, and premature blasts. Misfires lead to injuries and fatalities as miners try to shoot explosives that failed to detonate in the original blast. Premature blasts occur without warning while blasters are near the explosive-loaded boreholes; the explosive may be initiated by lightning, the impact of explosives being dropped down a dry borehole, or careless handling of the initiating system (blasting caps).

[NIOSH Office of Mine Safety and Health Research](#)

WHY DO MINING COMPANIES BLAST?

Blasting is the most cost effective way to fracture rock. Therefore, blasting reduces the cost of consumer goods such as electricity, sand, gravel and concrete. The old statement “If it can’t be grown, it can be mined” is still true today.

WHAT IS BLASTING?

Holes are drilled into the rock to be broken. A portion of each hole is filled with explosives. The top portion of the hole is filled with inert material call stemming. The explosive in each hole is initiated with detonators or blasting caps. The detonators are designed to create millisecond delay periods between individual holes or charges. A blast with 25 individual holes will essentially consist of smaller individual blasts, separated by millisecond delays and the entire blast may only last $\frac{1}{4}$ to $\frac{1}{2}$ of a second. When an explosive is detonated, it undergoes a very rapid decomposition which produces a large volume or expansion of gases, instantly. This expansion of gases is what causes the rock to fracture. The stemming material keeps the gases in the rock to maximize the amount of the energy utilized in the fragmentation process. The delay periods between charges ensures that each hole will only have to fragment the rock immediately in front of it, which enhances fragmentation.

BLASTING TOOLS:



Blasting machines



Threaded retriever



Brass powder punch



Title 30

Code of Federal Regulation

30 CFR § 57.6000

Definitions.

Blasting agent. Any substance classified as a blasting agent by the Department of Transportation in 49 CFR 173.114a(a). This document is available at any MSHA Metal and Nonmetal Safety and Health district office.

Detonating cord. A flexible cord containing a center core of high explosives which may be used to initiate other explosives.

Detonator. Any device containing a detonating charge used to initiate an explosive. These devices include electric or nonelectric instantaneous or delay blasting caps and delay connectors. The term "detonator" does not include detonating cord. Detonators may be either "Class A" detonators or "Class C" detonators, as classified by the Department of Transportation in 49 CFR 173.53, and 173.100. This document is available at any MSHA Metal and Nonmetal Safety and Health district office.

Explosive. Any substance classified as an explosive by the Department of Transportation in 49 CFR 173.53, 173.88, and 173.100. This document is available at any MSHA Metal and Nonmetal Safety and Health district office.

Explosive material. Explosives, blasting agents, and detonators.

Flash point. The minimum temperature at which sufficient vapor is released by a liquid to form a flammable vapor-air mixture near the surface of the liquid.

Igniter cord. A fuse that burns progressively along its length with an external flame at the zone of burning, used for lighting a series of safety fuses in a desired sequence.

Magazine. A bullet-resistant, theft-resistant, fire-resistant, weather-resistant, ventilated facility for the storage of explosives and detonators (BATF Type 1 or Type 2 facility).

Misfire. The complete or partial failure of explosive material to detonate as planned. The term also is used to describe the explosive material itself that has failed to detonate.

Primer. A unit, package, or cartridge of explosives which contains a detonator and is used to initiate other explosives or blasting agents.

Safety switch. A switch that provides shunt protection in blasting circuits between the blast site and the switch used to connect a power source to the blasting circuit.

Slurry. An explosive material containing substantial portions of a liquid, oxidizers, and fuel, plus a thickener.

Water gel. An explosive material containing substantial portions of water, oxidizers, and fuel, plus a cross-linking agent.

30 CFR § 75.1300

Definitions.

Approval. A document issued by MSHA which states that an explosive or explosive unit has met the requirements of this part and which authorizes an approval marking identifying the explosive or explosive unit as approved as permissible.

Battery starting. The use of unconfined explosives to start the flow of coal down a breast or chute in an anthracite mine.

Blasting off the solid. Blasting the working face without providing a second free face by cutting, shearing or other method before blasting.

Instantaneous detonator. An electric detonator that fires within 6 milliseconds after application of the firing current.

Laminated partition. A partition composed of the following material and minimum nominal dimensions: 1/2-inch thick plywood, 1/2-inch thick gypsum wall board, 1/8-inch thick low carbon steel and 1/4-inch thick plywood, bonded together in that order.

Opener hole. The first hole or holes fired in a round blasted off the solid to create an additional free face.

Permissible blasting unit. A device that has been approved by MSHA and that is used for firing electric detonators.

Permissible explosive. Any substance, compound or mixture which is approved by MSHA and whose primary purpose is to function by explosion.

Round. A group of boreholes fired or intended to be fired in a continuous sequence with one application of the firing current.

Sheathed explosive unit. A device consisting of an approved or permissible explosive covered by a sheath encased in a sealed covering and designed to be fired outside the confines of a borehole.

Short-delay electric detonator. An electric detonator with a designated delay period of 25 to 1,000 milliseconds.



Title 30

Code of Federal Regulation

30 CFR § 75.1301

Qualified person.

(a) A qualified person under this subpart is a person who

(1) Is certified or qualified to use explosives by the State in which the mine is located provided that the State requires a demonstration of ability to safely use permissible explosives as prescribed by this subpart effective January 17, 1989; or

(2) In States that do not certify or qualify persons to use explosives required by this section, has at least 1 year of experience working in an underground coal mine that includes direct involvement with procedures for handling, loading, and preparing explosives for blasting and demonstrates to an authorized representative of the Secretary the ability to use permissible explosives safely.

(b) Persons qualified or certified by a State to use permissible explosives in underground coal mines as of May 17, 1989, are considered qualified under this section even though their State program did not contain a demonstration of ability requirement.

30 CFR § 75.1310

Explosives and blasting equipment.

(a) Only permissible explosives, approved sheathed explosive units, and permissible blasting units shall be taken or used underground.

(b) Black blasting powder, aluminum-cased detonators, aluminum-alloy-cased detonators, detonators with aluminum leg wires, and safety fuses shall not be taken or used underground.

(c) Explosives shall be fired only with a permissible blasting unit used in a manner consistent with its approval. Blasting units approved by MSHA that have approval labels specifying use with short-delay detonators with delay periods between 25-500 milliseconds are accepted to fire short-delay detonators up to 1,000 milliseconds, instantaneous detonators and long period delay detonators for anthracite mines.

(d) Permissible explosives and sheathed explosive units shall not be used

underground when they are below the minimum product firing temperature specified by the approval. Explosives previously approved which do not specify a minimum firing temperature are permissible for use so long as the present approval is maintained.

(e) Electric detonators shall be compatible with the blasting unit and have sufficient strength to initiate the explosives being used.

30 CFR § 75.1311

Transporting explosives and detonators.

(a) When explosives and detonators are to be transported underground--

(1) They shall be enclosed in separate, substantially constructed containers made of nonconductive material, with no metal or other conductive materials exposed inside, except as specified in paragraph (d) of this section; and

(2) Each container of explosives and of detonators shall be indelibly marked with a readily visible warning identifying the contents.

(b) When explosives and detonators are transported by any cars or vehicles--

(1) The cars or vehicles shall be marked with warnings to identify the contents as explosive. The warnings shall be readily visible to miners approaching from any direction and in indelible letters;

(2) Explosives and detonators shall be transported either in separate cars or vehicles, or if in the same cars or vehicles as follows:

(b)(2)(i) Class A and Class C detonators in quantities greater than 1,000 shall be kept in the original containers as shipped from the manufacturer and separated from explosives by a hardwood partition at least 4 inches thick, a laminated partition or equivalent; and

(b)(2)(ii) Class A and Class C detonators in quantities of no more than 1,000 shall be separated from explosives by a hardwood partition at least 4 inches thick, a laminated partition or equivalent.

(3) No persons, other than those necessary to operate the equipment or to accompany the explosives and detonators, shall be transported with explosives and detonators, and

(4) When explosives and detonators are transported using trolley locomotives--

(b)(4)(i) Trips carrying explosives and detonators shall be separated from all other mantrips by at least a 5-minute interval; and

(b)(4)(ii) Cars containing explosives or detonators shall be separated from the locomotives by at least one car that is empty or that contains noncombustible materials.

(c) When explosives and detonators are transported on conveyor belts--

(1) Containers of explosives shall be separated from containers of detonators by at least 50 feet;

(2) At least 6 inches of clearance shall be maintained between the top of any container of explosives or container of detonators and the mine roof or other obstruction;

(3) Except when persons are riding the belt to accompany explosives or detonators, a person shall be at each transfer point between belts and at the unloading location; and

(4) Conveyor belts shall be stopped before explosives or detonators are loaded or unloaded.

(d) When explosives and detonators are transported by hand they shall be carried in separate, nonconductive, closed containers.

30 CFR § 75.1312

Explosives and detonators in underground magazines.

(a) The quantity of explosives kept underground shall not be more than is needed for 48 hours of use.

(b) Except as provided in [§75.1313](#), explosives and detonators taken underground shall be kept in--

(1) Separate, closed magazines at least 5 feet apart; or

(2) The same closed magazine when--

(b)(2)(i) Separated by a hardwood partition at least 4 inches thick; or

(b)(2)(ii) Separated by a laminated partition; or

(b)(2)(iii) Separated by a device that is equivalent.

(c) Only explosives and detonators shall be kept in underground magazines.

(d) Magazines shall be substantially constructed and all interior surfaces shall be made of nonconductive material, with no metal or other conductive material exposed inside.

(e) All magazines shall be--

(1) Located at least 25 feet from roadways and any source of electric current;

(2) Located out of the direct line of the forces from blasting; and

(3) Kept as dry as practicable.

(f) Magazine locations shall be posted with indelibly marked and readily visible warnings indicating the presence of explosives.

(g) Only materials and equipment to be used in blasting shall be stored at magazine locations.

30 CFR § 75.1313

Explosives and detonators outside of magazines.

(a) The quantity of explosives outside a magazine for use in a working section or other area where blasting is to be performed shall--

(1) Not exceed 100 pounds; or

(2) Not exceed the amount necessary to blast one round when more than 100 pounds of explosives is required.

(b) Explosives and detonators outside a magazine that are not being transported or prepared for loading boreholes shall be kept in closed separate containers made of nonconductive material with no metal or other conductive material exposed inside and the containers shall be--

(1) At least 15 feet from any source of electric current;

(2) Out of the direct line of the forces from blasting;

(3) In a location to prevent damage by mobile equipment; and

(4) Kept as dry as practicable.

(c) Explosives and detonators not used during the shift shall be returned to a magazine by the end of the shift.

30 CFR § 75.1314

Sheathed explosive units.

(a) A separate instantaneous detonator shall be used to fire each sheathed explosive unit.

(b) Sheathed explosive units shall be primed and placed in position for firing only by a qualified person or a person working in the presence of and under the direction of a qualified person. To prime a sheathed explosive unit, the entire detonator shall be inserted into the detonator well of the unit and be held securely in place.

(c) Sheathed explosive units shall not be primed until immediately before the units are placed where they are to be fired. A sheathed explosive unit shall not be primed if it is damaged or deteriorated.

(d) Except in anthracite mines, rock dust shall be applied to the roof, ribs and floor within a 40-foot radius of the location where the sheathed explosive units are to be fired.

(e) No more than three sheathed explosive units shall be fired at one time.

(f) No sheathed explosive unit shall be fired in contact with another sheathed explosive unit.

30 CFR § 75.1315
Boreholes for explosives.

(a) All explosives fired underground shall be confined in boreholes except

(1) Sheathed explosives units and other explosive units approved by MSHA for firing outside the confines of a borehole; and

(2) Shots fired in anthracite mines for battery starting or for blasting coal overhangs. No person shall go inside a battery to start the flow of material.

(b) Each borehole in coal for explosives shall be at least 24 inches from any other borehole and from any free face, unless prohibited by the thickness of the coal seam.

(c) Each borehole in rock for explosives shall be at least 18 inches from any other borehole in rock, at least 24 inches from any other borehole in coal, and at least 18 inches from any free face.

(d) No borehole that has contained explosives shall be used for starting any other hole.

(e) When blasting slab rounds off the solid, opener holes shall not be drilled beyond the rib line.

(f) When coal is cut for blasting, the coal shall be supported if necessary to maintain the stability of the column of explosives in each borehole.

30 CFR § 75.1316

Preparation before blasting.

(a)(1) All nonbattery-powered electric equipment, including cables, located within 50 feet from boreholes to be loaded with explosives or the sites where sheathed explosive units are to be placed and fired shall be deenergized or removed to at least 50 feet from these locations before priming of explosives. Battery-powered equipment shall be removed to at least 50 feet from these locations before priming of explosives.

(2) As an alternative to paragraph (a)(1) of this section, electric equipment, including cables, need not be deenergized or removed if located at least 25 feet from these locations provided stray current tests conducted prior to priming the explosives detect stray currents of 0.05 ampere or less through a 1-ohm resistor.

(a)(2)(i) Tests shall be made at floor locations on the perimeter, on energized equipment frames and on repaired areas of energized cables within the area between 25 to 50 feet from the locations where the explosives are to be primed.

(a)(2)(ii) Tests shall be conducted using a blasting multimeter or other instrument specifically designed for such use.

(3) The blasting cable or detonator circuitry shall not come in contact with energized electric equipment, including cables.

(b) Before loading boreholes with explosives, each borehole shall be cleared and its depth and direction determined.

(c) No borehole drilled beyond the depth of cut coal shall be loaded with explosives unless that portion of the borehole deeper than the cut is tamped with noncombustible material.

(d) When two working faces are approaching each other, cutting, drilling and blasting shall be done at only one working face at a time if the two faces are within 25 feet of each other.

30 CFR § 75.1317

Primer cartridges.

(a) Primer cartridges shall be primed and loaded only by a qualified person or a person working in the presence of and under the direction of a qualified person.

(b) Primer cartridges shall not be primed until immediately before loading boreholes.

(c) Only a nonsparking punch shall be used when priming explosive cartridges.

(d) Detonators shall be completely within and parallel to the length of the cartridge and shall be secured by half-hitching the leg wires around the cartridge or secured by an equally effective method.

30 CFR § 75.1318
Loading boreholes.

(a) Explosives shall be loaded by a qualified person or a person working in the presence of and under the direction of a qualified person.

(b) When boreholes are being loaded, no other work except that necessary to protect persons shall be done in the working place or other area where blasting is to be performed.

(c) When loading boreholes drilled at an angle of 45 degrees or greater from the horizontal in solid rock or loading long holes drilled upward in anthracite mines--

(1) The first cartridge in each borehole shall be the primer cartridge with the end of the cartridge containing the detonator facing the back of the borehole; and

(2) The explosive cartridges shall be loaded in a manner that provides contact between each cartridge in the borehole.

(d) When loading other boreholes--

(1) The primer cartridge shall be the first cartridge loaded in the borehole;

(2) The end of the cartridge in which the detonator is inserted shall face the back of the borehole; and

(3) The primer cartridge and other explosives shall be pushed to the back of the borehole in a continuous column with no cartridge being deliberately crushed or deformed.

(e) An explosive shall not be loaded into a borehole if it is damaged, deteriorated or if the cartridge is incompletely filled.

(f) Explosives of different brands, types or cartridge diameters shall not be loaded in the same borehole.

(g) Only nonconductive, nonsparking tamping poles shall be used for loading and tamping boreholes. The use of nonsparking connecting devices for extendable tamping poles is permitted.

30 CFR § 75.1319

Weight of explosives permitted in boreholes in bituminous and lignite mines.

(a) The total weight of explosives loaded in any borehole in bituminous and lignite mines shall not exceed 3 pounds except when blasting solid rock in its natural deposit.

(b) The total weight of explosives loaded in a borehole less than 6 feet deep in bituminous and lignite mines shall be reduced by 1/2 pound for each foot of borehole less than 6 feet.

30 CFR § 75.1320

Multiple-shot blasting.

(a) No more than 20 boreholes shall be fired in a round unless permitted in writing by the District Manager under [§75.1321](#).

(b) Instantaneous detonators shall not be used in the same circuit with delay detonators in any underground coal mine.

(c) In bituminous and lignite mines, only detonators with delay periods of 1,000 milliseconds or less shall be used.

(d) When blasting in anthracite mines, each borehole in a round shall be initiated in sequence from the opener hole or holes.

(e) Arrangement of detonator delay periods for bituminous and lignite mines shall be as follows:

(1) When blasting cut coal--

(e)(1)(i) The first shot or shots fired in a round shall be initiated in the row nearest the kerf or the row or rows nearest the shear; and

(e)(1)(ii) After the first shot or shots, the interval between the designated delay periods of successive shots shall be at least 50 milliseconds but not more than 100 milliseconds.

(2) When blasting coal off the solid--

(e)(2)(i) Each shot in the round shall be initiated in sequence from the opener hole or holes; and

(e)(2)(ii) After the first shot or shots, the interval between the designated delay periods of successive shots shall be at least 50 milliseconds but not more than 100 milliseconds.

30 CFR § 75.1321

Permits for firing more than 20 boreholes and for use of nonpermissible blasting units.

(a) Applications for permits for firing more than 20 boreholes in a round and for the use of nonpermissible blasting units shall be submitted in writing to the District Manager for the district in which the mine is located and shall contain the following information:

(1) The name and address of the mine;

(2) The active workings in the mine affected by the permit and the approximate number of boreholes to be fired;

(3) The period of time during which the permit will apply;

(4) The nature of the development or construction for which they will be used, e.g., overcasts, undercasts, track grading, roof brushing or boom holes;

(5) A plan, proposed by the operator designed to protect miners in the mine from the hazards of methane and other explosive gases during each multiple shot, e.g., changes in the mine ventilation system, provisions for auxiliary ventilation and any other safeguards necessary to minimize such hazards;

(6) A statement of the specific hazards anticipated by the operator in blasting for overcasts, undercasts, track grading, brushing of roof, boom holes or other unusual blasting situations such as coalbeds of abnormal thickness; and

(7) The method to be employed to avoid the dangers anticipated during development or construction which will ensure the protection of life and the prevention of injuries to the miners exposed to such underground blasting.

(b) The District Manager may permit the firing of more than 20 boreholes of permissible explosives in a round where he has determined that it is necessary to reduce the overall hazard to which miners are exposed during underground blasting. He may also permit the use of nonpermissible blasting units if he finds that a permissible blasting unit does not have adequate blasting capacity and that the use of such permissible units will create any of the following development or construction hazards:

(1) Exposure to disturbed roof in an adjacent cavity while scaling and supporting the remaining roof prior to wiring a new series of boreholes;

(2) Exposure to underburden boreholes where prior rounds have removed the burden adjacent to a remaining borehole;

(3) Exposure to an unsupported roof while redrilling large fragmented roof rock

following the loss of predrilled boreholes during earlier blasting operations; or

(4) Any other hazard created by the use of permissible blasting units during underground development or construction.

(c) Permits shall be issued on a mine-by-mine basis for periods of time to be specified by the District Manager.

(d) Permits issued under this section shall specify and include as a condition of their use, any safeguards, in addition to those proposed by the operator, which the District Manager issuing such permit has determined will be required to ensure the welfare of the miners employed in the mine at the time of the blasting permitted.

30 CFR § 75.1322

Stemming boreholes

(a) Only noncombustible material shall be used for stemming boreholes.

(b) Stemming materials other than water stemming bags shall be tamped to fill the entire cross sectional area of the borehole.

(c) Stemming material shall contact the explosive cartridge nearest the collar of the borehole.

(d) Each borehole 4 or more feet deep shall be stemmed for at least 24 inches.

(e) Each borehole less than 4 feet deep shall be stemmed for at least half the depth of the borehole.

(f) When blasting off the solid in bituminous and lignite mines, only pliable clay dummies shall be used for stemming.

(g) The diameter of a water stemming bag shall be within 1/4 of an inch of the diameter of the drill bit used to drill the borehole.

(h) Water stemming bags shall be constructed of tear-resistant and flame-resistant material and be capable of withstanding a 3-foot drop when filled without rupturing or developing leaks.

30 CFR § 75.1323

Blasting circuits.

(a) Blasting circuits shall be protected from sources of stray electric current.

(b) Detonators made by different manufacturers shall not be combined in the same blasting circuit.

(c) Detonator leg wires shall be shunted until connected into the blasting circuit.

(d) Blasting cables shall be--

(1) Well insulated, copper wire of a diameter not smaller than 18-gauge; and

(2) Long enough to permit the round to be fired from a safe location that is around at least one corner from the blasting area.

(e) Blasting cables shall be shunted until immediately before firing, except when testing for circuit continuity.

(f) Wire used between the blasting cable and detonator circuitry shall--

(1) Be undamaged;

(2) Be well insulated;

(3) Have a resistance no greater than 20-gauge copper wire; and

(4) Be not more than 30 feet long.

(g) Each wire connection in a blasting circuit shall be--

(1) Properly spliced; and

(2) Separated from other connections in the circuit to prevent accidental contact and arcing.

(h) Uninsulated connections in each blasting circuit shall be kept out of water and shall not contact the coal, roof, ribs, or floor.

(i) When 20 or fewer boreholes are fired in a round, the blasting circuit shall be wired in a single series.

(j) Immediately prior to firing, all blasting circuits shall be tested for continuity and resistance using a blasting galvanometer or other instrument specifically designed for testing blasting circuits.

30 CFR § 75.1324

Methane concentration and tests.

(a) No shot shall be fired in an area that contains 1.0 volume percent or more of methane.

(b) Immediately before shots are fired, the methane concentration in a working place or any other area where blasting is to be performed, shall be determined by a person qualified to test for methane.

30 CFR § 75.1325
Firing procedures.

(a) Shots shall be fired by a qualified person or a person working in the presence of and under the direction of a qualified person.

(b) Only one face in a working place shall be blasted at a time, except that when blasting cut coal up to three faces may be blasted in a round if each face has a separate kerf and no more than a total of 20 shots connected in a single series are fired in the round. A permit to fire more than 20 boreholes in a round under the provisions of 30 CFR [75.1320](#) and [75.1321](#) may not be obtained for use when blasting multiple faces.

(c) Before blasting--

(1) All persons shall leave the blasting area and each immediately adjacent working place where a hazard would be created by the blast, to an area that is around at least one corner from the blasting area;

(2) The qualified person shall ascertain that all persons are a safe distance from the blasting area; and

(3) A warning shall be given and adequate time allowed for persons to respond.

(d) All shots shall be fired promptly, after all persons have been removed to a safe location.

30 CFR § 75.1326
Examination after blasting.

(a) After blasting, the blasting area shall not be entered until it is clear of smoke and dust.

(b) Immediately after the blasting area has cleared, a qualified person or a person working in the presence of and under the direction of a qualified person, shall examine the area for misfires, methane and other hazardous conditions.

(c) If a round has partially detonated, the qualified person shall immediately leave the area and no person shall reenter the affected area for at least 5 minutes.

30 CFR § 75.1327

Misfires.

(a) When misfires occur, only work by a qualified person to dispose of misfires and other work necessary to protect persons shall be done in the affected area.

(b) When a misfire cannot be disposed of--

(1) A qualified person shall post each accessible entrance to the area affected by the hazard of the misfire with a warning at a conspicuous location to prohibit entry; and

(2) The misfire shall be immediately reported to mine management.

30 CFR § 75.1328

Damaged or deteriorated explosives and detonators.

(a) Damaged explosives or detonators shall be--

(1) Placed in separate containers constructed of nonconductive and nonsparking materials; and

(2) Removed from the mine or placed in a magazine and removed when the magazine is resupplied.

(b) Damaged detonators shall be shunted, if practicable, either before being removed from the mine or placed in a magazine.

(c) Deteriorated explosives and detonators shall be handled and disposed of in accordance with the instructions of the manufacturer.

Subpart O--Hoisting and Mantrips

BLASTING AND EXPLOSIVES

Questions for Review

Q: What is a misfire?

Q: What is a detonating cord?

Q: What does “blasting off the solid” mean?

Q: What is a magazine?

Q: What is a sheathed explosive unit?

Q: What is an instantaneous detonator?

Q: What must be done with damaged or deteriorated detonators?

A: CFR 75.1328

Q: No shot shall be fired in an area that has a methane content of what percentage?

A: CFR 75.1324

Q: What is the limit for sheathed explosive units being fired at one time?

A: CFR 75.1314

Q: Magazines shall be located at least how far away from roadways and any source of electric current?

A: CFR 75.1312 (e)

Q: If a round has partially detonated, what must happen?

A: CFR 75.1326

Q: How long must blasting cables be?

A: CFR 75.1323 (d)(2)

Q: What must happen before blasting is done?

A: CFR 75.1325 (c)

Q: How far must each borehole, less than 4 feet deep, be stemmed?

A: CFR 75.1322

Q: When blasting off the solid in bituminous and lignite mines, what can be used for stemming?

A: CFR 75.1322 (f)

Q: A Permit is required if you are firing more than how many boreholes?

A: CFR 75.1321

Q: Blasting circuits must be protected from what?

A: CFR 75.1323 (a)

Q: Primer cartridges shall be primed and loaded only by whom?

A: CFR 75.1317

Q: How shall explosives and detonators be transported underground?

A: CFR 75.1311
